



GIOVENZANA
INTERNATIONAL B.V.

TECHNO-CONTROL EQUIPMENT

GENERAL CATALOGUE

GIOVENZANA INTERNATIONAL reserves the right to modify, in order to improve their performance, all technical and functional characteristics of the products showed on the catalogue without prior notice as these information are intended for general knowledge and they are not legally binding.

THE PHILOSOPHY

Giovenzana's philosophy is based upon the basic principles of business management, dynamism and the continuous research for the operator's needs in the field of man-machine interaction. These principles, thanks to the experience and professionalism of its staff, guarantees **Giovenzana's** development and growth.

THE HISTORY

With over 50 years experience in this field and excellent managerial skills, **Giovenzana** has maintained growth relying upon:

- market research
- product placement
- manufacturing technology, and above all, team work

THE PRODUCTS

Giovenzana, leader in the industrial technology field, is the first choice for:

- handling equipment
- automation
- lifting equipment
- maintenance
- command and control of moving parts

Development, design and production are combined together to reach a common aim and cover most industrial applications.

QUALITY AS A WAY OF LIFE

The commercial success of a product is not by chance, but it is the end result of a combined effort of all human resources operating within an organisational structure devoted to quality. **Giovenzana** is an ISO 9001 certified company.



GIOVENZANA INTERNATIONAL B.V.

The Company

THE PRODUCTION

The solutions offered by **Giovenzana** are the outcome of a close examination of the requirements of industrial electrical accessories, in line with all relevant international standards.

It comprises three main sectors:
Industrial automation, lift and lifting equipment.

AUTOMATION

It includes Phoenix cam switches and Regolus switch-disconnectors up to 100A, Pegasus control auxiliaries with screw or spring loaded terminal contact blocks; limit switches with die-cast or moulded casing and safety switches; foot switches and micro switches.

LIFT

Throughout the years, the continuous technological research and development made **Giovenzana** the undisputed leader in this field. The range includes: pit bottom push button stations, recall drive control units and inspection boxes.

LIFTING EQUIPMENT

It comprises single and double row pendant stations up to 14 gang for control and direct switching power circuits, reversing switches, worm screw and rotary limit switches, slip rings, horns, festoon systems and conductor rails.





QUALITY

Giovenzana, leader in the elevator and lifting equipment fields, has gained a prominent position in the automation sector as well with the launch of industrial control accessories on the market. For many years now, all commercial and industrial operations are integrated within the frame of the UNI EN ISO 9001 quality system.

CSQ certificate No. 9105

Giovenzana has fulfilled its commitment to the quality of its products in 1995.

The quality system is the guarantee to the end user that all production stages are maintained under strict control and adhere to the requirements set by the company both in terms of customer expectations and compliance with the relevant international standards as proved by the various certificates held by Giovenzana for its products.



COMPLIANCE

All **Giovenzana** products are manufactured according to the relevant Cee directives and are provided with a declaration of conformity which certifies their compliance.



CERTIFICATIONS

For many years, **Giovenzana** has been submitting its products for third party testing to one of the most prestigious independent certification body around the world, the Underwriter Laboratories Inc. in order to obtain the UL mark. Today the number of independent certification bodies approving **Giovenzana's** products is even bigger to signal the high level of quality achieved.

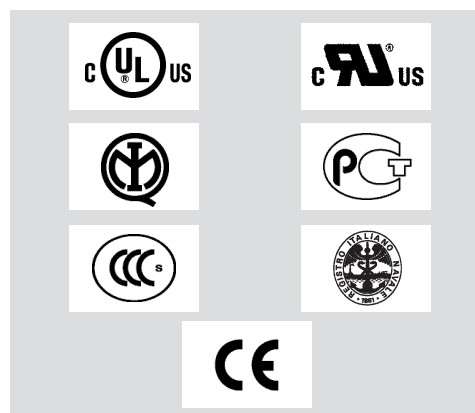

GIOVENZANA INTERNATIONAL B.V.

Certifications

CEE DIRECTIVES

As from the 1st of January 1997, it is compulsory to CE mark all electromechanical products: this has been outlined by two important regulations: 72/23 CEE and 93/68 CEE Low Voltage Directives.

CE MARK

European directives, applied to all national regulations, set the minimum requirements in term of safety of all electrical material sold within the EU. The compliance to these requirements is certified to the manufacturer by the CE mark placed on the products.

STANDARDS

Giovenzana's products comply with both European EN and American UL standards. These regulations, such as the EN 60024 with regards to the safety requirements of the electrical circuits on board industrial machinery, define the characteristics and performance or the characteristics and use of the products.

EN EUROPEAN STANDARDS

These standards are the result of the harmonisation among CENELEC (European Committee for Electrotechnical Standardization) member countries. They cover and eliminate existing national standards which may be in contradiction or not up to date. EN European standards usually originate from IEC International standards.





AUTOMATION

- Phoenix cam switches pag. 11
- Regolus switch-disconnectors pag. 35
- Pegasus control auxiliaries pag. 45
- Limit switches pag. 71
- Microswitches pag. 95
- Foot switches pag. 97

LIFT

- Pit bottom push button stations pag. 103
- Recall drive control units

LIFTING EQUIPMENT

- Pendant stations for: Small hoist applications pag. 113
- Control circuits - Direct switching power circuits
- Tail lift push button stations
- Reversing switches pag. 132
- Rotary cross bar and rotary gear limit switches pag. 133
- Slip rings pag. 137
- Horns pag. 141
- Festoon systems pag. 143
- Conductor rails pag. 164

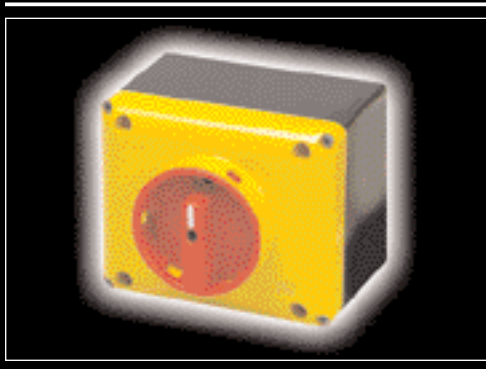
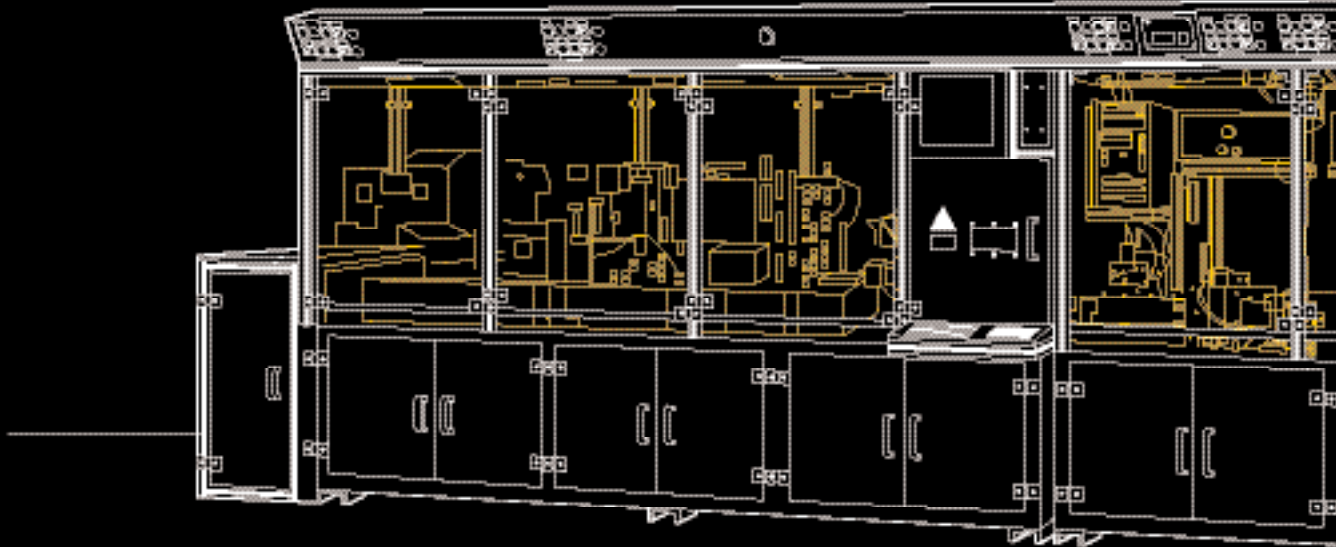
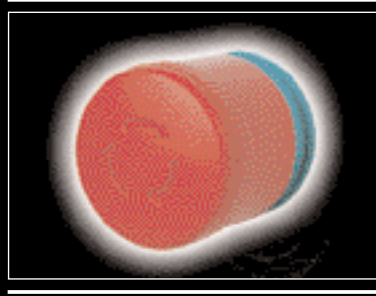

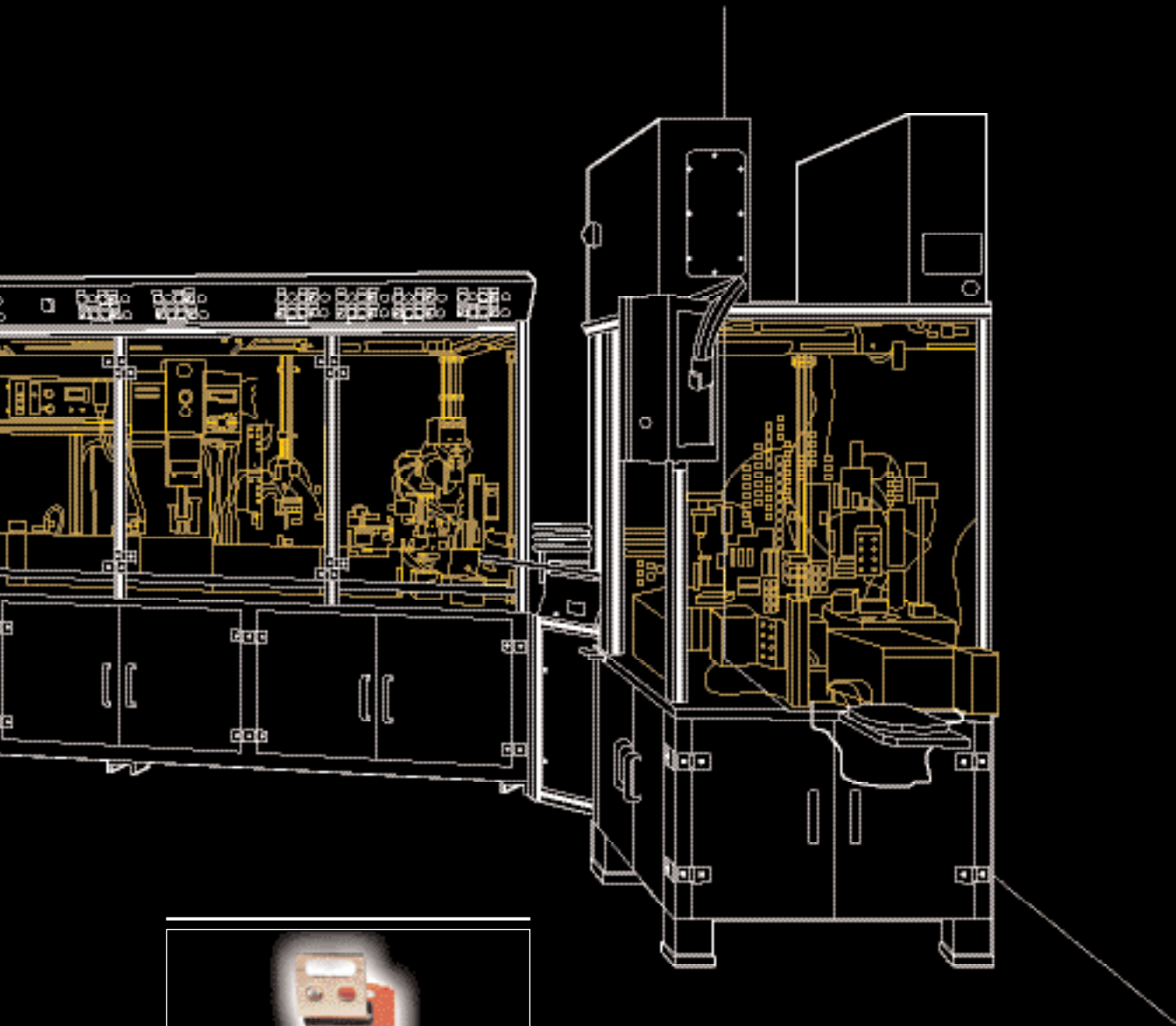

Phoenix

Cam switches

Table of contents



TECHNO-CONTROL EQUIPMENT

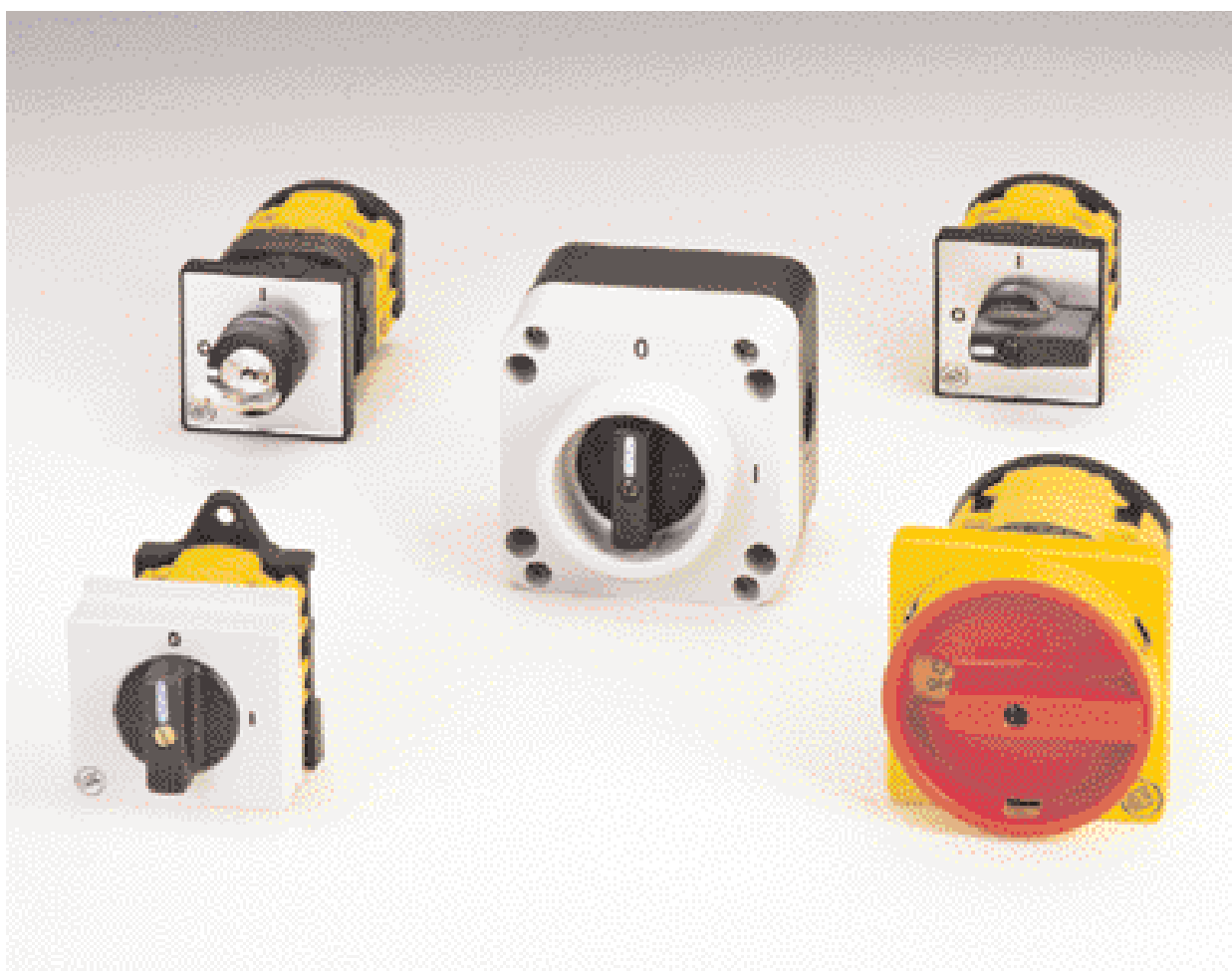

Current rating from 12 up to 40A. Base, DIN and panel mounted with fixing screws or \varnothing 22.5 holes. Wide range of circuit diagrams available. Special version made to order.

TABLE OF CONTENTS

■ Range overview	pag. 12	■ Panel-mounted step switches - DIN rail mounted Instrumentation switches	pag. 26
■ Panel-mounted switches	pag. 13	■ Special switches	pag. 27
■ Box-DIN rail mounted switches	pag. 19	■ Accessories	pag. 28
■ Panel-mounted line changeover switches	pag. 21	■ Technical data	pag. 30
■ Panel-mounted motor changeover switches	pag. 22	■ Dimensions	pag. 32
■ Instrumentation switches – Changeover without off switches	pag. 25	■ Circuit diagrams	pag. 34

Phoenix

Control switches

Range overview

PO12 - PO16 - PO20 SERIES

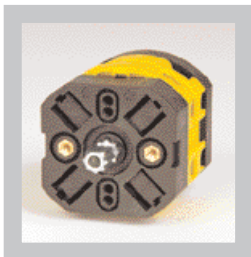

- Panel mounting by means of horizontal fixing holes, 28 mm distance, for M3 screws or vertical fixing holes, 32 mm distance, for self tapping screws.
- Wafers secured by means of screws
- Metal shaft as standard
- IP20 rated terminals

CO12 - CO16 - CO20 SERIES

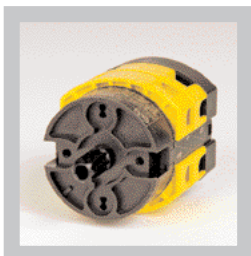

- Panel mounting by means of vertical fixing holes for self tapping screws
 - Wafers secured by means of clip-on tie rod
 - Moulded shaft as standard
 - IP20 rated terminals
- *Replace the letter "P" with "C" to order this range.
PO12... becomes CO12...

CO25 - CO32 - CO40 SERIES

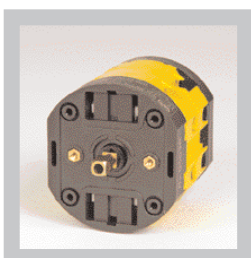

- Panel mounting by means of horizontal fixing holes for M3 screws
- Wafers secured by means of screws
- Metal shaft as standard
- IP20 rated terminals

CX25 - CX32 - CX40 SERIES

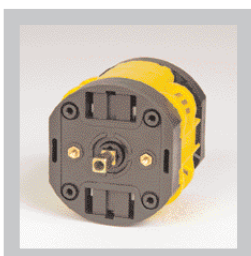

- Panel mounting by means of horizontal fixing holes for M3 screws
 - Wafers secured by means of screws
 - Metal shaft as standard
 - IP10 rated terminals for special applications
- *Replace the number "O" with the letter "X" to order this range.
CO25... becomes CX25...

Phoenix

Control switches

Panel mounting



TECHNO-CONTROL EQUIPMENT



Standard control knob

001 48
007 64

SERIES	NOM. CURRENT AC21A AMP.	MARKING	1-POLE 1 WAFER	2-POLE 1 WAFER	3-POLE 2 WAFERS	4-POLE 2 WAFERS	5-POLE 3 WAFERS	6-POLE 3 WAFERS
P012	12	<input type="checkbox"/> 48 <input type="checkbox"/>	P0120001R001	P0120002R001	P0120003R001	P0120004R001	P0120005R001	P0120006R001
P016	16		P0160001R001	P0160002R001	P0160003R001	P0160004R001	P0160005R001	P0160006R001
P020	20		P0200001R001	P0200002R001	P0200003R001	P0200004R001	P0200005R001	P0200006R001
C025	25		C0250001R001	C0250002R001	C0250003R001	C0250004R001	C0250005R001	C0250006R001
C032	32		C0320001R001	C0320002R001	C0320003R001	C0320004R001	C0320005R001	C0320006R001
C040	40	<input type="checkbox"/> 48 <input type="checkbox"/>	C0400001R001	C0400002R001	C0400003R001	C0400004R001	C0400005R001	C0400006R001
P012	12	<input type="checkbox"/> 48 <input type="checkbox"/>	P0120001R001-1	P0120002R001-1	P0120003R001-1	P0120004R001-1	P0120005R001-1	P0120006R001-1
P016	16		P0160001R001-1	P0160002R001-1	P0160003R001-1	P0160004R001-1	P0160005R001-1	P0160006R001-1
P020	20		P0200001R001-1	P0200002R001-1	P0200003R001-1	P0200004R001-1	P0200005R001-1	P0200006R001-1
C025	25		C0250001R001-1	C0250002R001-1	C0250003R001-1	C0250004R001-1	C0250005R001-1	C0250006R001-1
C032	32		C0320001R001-1	C0320002R001-1	C0320003R001-1	C0320004R001-1	C0320005R001-1	C0320006R001-1
C040	40	<input type="checkbox"/> 48 <input type="checkbox"/>	C0400001R001-1	C0400002R001-1	C0400003R001-1	C0400004R001-1	C0400005R001-1	C0400006R001-1
P012	12	<input type="checkbox"/> 64 <input type="checkbox"/>	P0120001R007	P0120002R007	P0120003R007	P0120004R007	P0120005R007	P0120006R007
P016	16		P0160001R007	P0160002R007	P0160003R007	P0160004R007	P0160005R007	P0160006R007
P020	20		P0200001R007	P0200002R007	P0200003R007	P0200004R007	P0200005R007	P0200006R007
C025	25		C0250001R007	C0250002R007	C0250003R007	C0250004R007	C0250005R007	C0250006R007
C032	32		C0320001R007	C0320002R007	C0320003R007	C0320004R007	C0320005R007	C0320006R007
C040	40	<input type="checkbox"/> 64 <input type="checkbox"/>	C0400001R007	C0400002R007	C0400003R007	C0400004R007	C0400005R007	C0400006R007
P012	12	<input type="checkbox"/> 64 <input type="checkbox"/>	P0120001R007-1	P0120002R007-1	P0120003R007-1	P0120004R007-1	P0120005R007-1	P0120006R007-1
P016	16		P0160001R007-1	P0160002R007-1	P0160003R007-1	P0160004R007-1	P0160005R007-1	P0160006R007-1
P020	20		P0200001R007-1	P0200002R007-1	P0200003R007-1	P0200004R007-1	P0200005R007-1	P0200006R007-1
C025	25		C0250001R007-1	C0250002R007-1	C0250003R007-1	C0250004R007-1	C0250005R007-1	C0250006R007-1
C032	32		C0320001R007-1	C0320002R007-1	C0320003R007-1	C0320004R007-1	C0320005R007-1	C0320006R007-1
C040	40	<input type="checkbox"/> 64 <input type="checkbox"/>	C0400001R007-1	C0400002R007-1	C0400003R007-1	C0400004R007-1	C0400005R007-1	C0400006R007-1

SERIES	NOM. CURRENT AC21A AMP.	MARKING	3-POLE RETRACTIVE 3 WAFERS
P012	12	<input type="checkbox"/> 48 <input type="checkbox"/>	P0120007R001
P016	16		P0160007R001
P020	20		P0200007R001
C025	25		C0250007R001
C032	32		C0320007R001
C040	40	<input type="checkbox"/> 48 <input type="checkbox"/>	C0400007R001
P012	12	<input type="checkbox"/> 64 <input type="checkbox"/>	P0120007R007
P016	16		P0160007R007
P020	20		P0200007R007
C025	25		C0250007R007
C032	32		C0320007R007
C040	40	<input type="checkbox"/> 64 <input type="checkbox"/>	C0400007R007

NOTE:

The C012, C016, C020 series can be supplied upon request. To make your order replace the letter "P" in the reference numbers of the P012, P016, P020 series respectively with the letter "C": P0120001R001 becomes C0120001R001.

These series are not available in the O56-O62 operator versions. For the O27 operator replace the reference with "015": P0160003R027 becomes C0160003R015

Phoenix

Control switches

Panel mounting



Red knob
002 48
008 64



Red knob
 with locking facility
004
 Black knob
 with locking facility
003



SERIES	NOM. CURRENT AC21A AMP.	MARKING	3-POLE 2 WAFERS		MARKING	3-POLE 2 WAFERS		4-POLE 2 WAFERS	
PO12	12	<input type="checkbox"/> 48 <input type="checkbox"/>	PO120003R002	PO120004R002	<input type="checkbox"/> 48 <input type="checkbox"/>	PO120003R003	PO120004R003	PO120003R003	PO120004R003
PO16	16		PO160003R002	PO160004R002		PO160003R003	PO160004R003	PO160003R003	PO160004R003
PO20	20		PO200003R002	PO200004R002		PO200003R003	PO200004R003	PO200003R003	PO200004R003
CO25	25		CO250003R002	CO250004R002		CO250003R003	CO250004R003	CO250003R003	CO250004R003
CO32	32		CO320003R002	CO320004R002		CO320003R003	CO320004R003	CO320003R003	CO320004R003
CO40	40		CO400003R002	CO400004R002		CO400003R003	CO400004R003	CO400003R003	CO400004R003
PO12	12	<input type="checkbox"/> 64 <input type="checkbox"/>	PO120003R008	PO120004R008	<input type="checkbox"/> 48 <input type="checkbox"/>	PO120003R004	PO120004R004	PO120003R004	PO120004R004
PO16	16		PO160003R008	PO160004R008		PO160003R004	PO160004R004	PO160003R004	PO160004R004
PO20	20		PO200003R008	PO200004R008		PO200003R004	PO200004R004	PO200003R004	PO200004R004
CO25	25		CO250003R008	CO250004R008		CO250003R004	CO250004R004	CO250003R004	CO250004R004
CO32	32		CO320003R008	CO320004R008		CO320003R004	CO320004R004	CO320003R004	CO320004R004
CO40	40		CO400003R008	CO400004R008		CO400003R004	CO400004R004	CO400003R004	CO400004R004



Grey escutcheon,
 black disc-type knob
 with locking facility for 3 padlocks
009

Yellow escutcheon,
 red disc-type knob
 with locking facility for 3 padlocks
010



SERIES	NOM. CURRENT AC21A AMP.	MARKING	3-POLE 2 WAFERS		MARKING	3-POLE 2 WAFERS		4-POLE 2 WAFERS	
PO12	12	<input type="checkbox"/> 67 <input type="checkbox"/>	PO120003R009	PO120004R009	<input type="checkbox"/> 67 <input type="checkbox"/>	PO120003R010	PO120004R010	PO120003R010	PO120004R010
PO16	16		PO160003R009	PO160004R009		PO160003R010	PO160004R010	PO160003R010	PO160004R010
PO20	20		PO200003R009	PO200004R009		PO200003R010	PO200004R010	PO200003R010	PO200004R010
CO25	25		CO250003R009	CO250004R009		CO250003R010	CO250004R010	CO250003R010	CO250004R010
CO32	32		CO320003R009	CO320004R009		CO320003R010	CO320004R010	CO320003R010	CO320004R010
CO40	40		CO400003R009	CO400004R009		CO400003R010	CO400004R010	CO400003R010	CO400004R010
PO12	12	<input type="checkbox"/> 67 <input type="checkbox"/>	PO120003R009-1	PO120004R009-1	<input type="checkbox"/> 67 <input type="checkbox"/>	PO120003R010-1	PO120004R010-1	PO120003R010-1	PO120004R010-1
PO16	16		PO160003R009-1	PO160004R009-1		PO160003R010-1	PO160004R010-1	PO160003R010-1	PO160004R010-1
PO20	20		PO200003R009-1	PO200004R009-1		PO200003R010-1	PO200004R010-1	PO200003R010-1	PO200004R010-1
CO25	25		CO250003R009-1	CO250004R009-1		CO250003R010-1	CO250004R010-1	CO250003R010-1	CO250004R010-1
CO32	32		CO320003R009-1	CO320004R009-1		CO320003R010-1	CO320004R010-1	CO320003R010-1	CO320004R010-1
CO40	40		CO400003R009-1	CO400004R009-1		CO400003R010-1	CO400004R010-1	CO400003R010-1	CO400004R010-1

Phoenix

Control switches

Panel mounting



TECHNO-CONTROL EQUIPMENT



Round
escutcheon
013 \varnothing 59
014 \varnothing 52

SERIES	NOM. CURRENT AC21A AMP.	MARKING	1-POLE 1 WAFER	2-POLE 1 WAFER	3-POLE 2 WAFERS	4-POLE 2 WAFERS	5-POLE 3 WAFERS
P012	12	\varnothing 59 	P0120001R013	P0120002R013	P0120003R013	P0120004R013	P0120005R013
P016	16		P0160001R013	P0160002R013	P0160003R013	P0160004R013	P0160005R013
P020	20	90°	P0200001R013	P0200002R013	P0200003R013	P0200004R013	P0200005R013
P012	12	\varnothing 52 	P0120001R014	P0120002R014	P0120003R014	P0120004R014	P0120005R014
P016	16		P0160001R014	P0160002R014	P0160003R014	P0160004R014	P0160005R014
P020	20	90°	P0200001R014	P0200002R014	P0200003R014	P0200004R014	P0200005R014



Round
escutcheon
013 \varnothing 59
014 \varnothing 52

SERIES	NOM. CURRENT AC21A AMP.	MARKING	5-POLE 3 WAFERS	MARKING	3-POLE RETRACTIVE 2 WAFERS
P012	12	\varnothing 59 	P0120006R013	\varnothing 59 	P0120007R013
P016	16		P0160006R013		P0160007R013
P020	20	90°	P0200006R013	45°	P0200007R013
P012	12	\varnothing 52 	P0120006R014	\varnothing 52 	P0120007R014
P016	16		P0160006R014		P0160007R014
P020	20	90°	P0200006R014	45°	P0200007R014

Phoenix



Control switches

Panel mounting

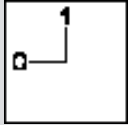

Black knob only
O18
O40

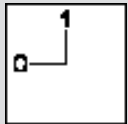
SERIES	NOM. CURRENT AC21A AMP.	POSITIONS	1-POLE 1 WAFER	2-POLE 1 WAFER	3-POLE 2 WAFERS	4-POLE 2 WAFERS	5-POLE 3 WAFERS
P012	12	 90°	P0120001R018	P0120002R018	P0120003R018	P0120004R018	P0120005R018
P016	16		P0160001R018	P0160002R018	P0160003R018	P0160004R018	P0160005R018
P020	20		P0200001R018	P0200002R018	P0200003R018	P0200004R018	P0200005R018
C025	25		C0250001R040	C0250002R040	C0250003R040	C0250004R040	C0250005R040
C032	32		C0320001R040	C0320002R040	C0320003R040	C0320004R040	C0320005R040
C040	40		C0400001R040	C0400002R040	C0400003R040	C0400004R040	C0400005R040

SERIES	NOM. CURRENT AC21A AMP.	POSITIONS	6-POLE 3 WAFERS	POSITIONS	3-POLE RETRACTIVE 2 WAFERS
P012	12	 90°	P0120006R018	 45°	P0120007R018
P016	16		P0160006R018		P0160007R018
P020	20		P0200006R018		P0200007R018
C025	25		C0250006R040		C0250007R040
C032	32		C0320006R040		C0320007R040
C040	40		C0400006R040		C0400007R040

Phoenix

Control switches

Panel mounting – Ø 22.5 hole



TECHNO-CONTROL EQUIPMENT



Central fixing Ø 22
with knob
028



Central fixing Ø 22
with key
029

SERIES	NOM. CURRENT AC21A AMP.	POSITIONS	1-POLE 1 WAFER	2-POLE 1 WAFER	3-POLE 2 WAFERS	4-POLE 2 WAFERS
PO12	12	 90°	PO120001R028	PO120002R028	PO120003R028	PO120004R028
PO16	16		PO160001R028	PO160002R028	PO160003R028	PO160004R028
PO20	20		PO200001R028	PO200002R028	PO200003R028	PO200004R028
PO12	12		PO120001R029	PO120002R029	PO120003R029	PO120004R029
PO16	16	 90°	PO160001R029	PO160002R029	PO160003R029	PO160004R029
PO20	20		PO200001R029	PO200002R029	PO200003R029	PO200004R029



Central fixing Ø 22
□ 48
with black knob
056 056-1



Central fixing Ø 22
□ 48
with key
057 057-1

SERIES	NOM. CURRENT AC21A AMP.	MARKING	1-POLE 1 WAFER	2-POLE 1 WAFER	3-POLE 2 WAFERS	4-POLE 2 WAFERS	5-POLE 3 WAFERS	6-POLE 3 WAFERS
PO12	12	 48	PO120001R056	PO120002R056	PO120003R056	PO120004R056	PO120005R056	PO120006R056
PO16	16		PO160001R056	PO160002R056	PO160003R056	PO160004R056	PO160005R056	PO160006R056
PO20	20		PO200001R056	PO200002R056	PO200003R056	PO200004R056	PO200005R056	PO200006R056
PO12	12		PO120001R057	PO120002R057	PO120003R057	PO120004R057	PO120005R057	PO120006R057
PO16	16	 90°	PO160001R057	PO160002R057	PO160003R057	PO160004R057	PO160005R057	PO160006R057
PO20	20		PO200001R057	PO200002R057	PO200003R057	PO200004R057	PO200005R057	PO200006R057
PO12	12	 48	PO120001R056-1	PO120002R056-1	PO120003R056-1	PO120004R056-1	PO120005R056-1	PO120006R056-1
PO16	16		PO160001R056-1	PO160002R056-1	PO160003R056-1	PO160004R056-1	PO160005R056-1	PO160006R056-1
PO20	20		PO200001R056-1	PO200002R056-1	PO200003R056-1	PO200004R056-1	PO200005R056-1	PO200006R056-1
PO12	12		PO120001R057-1	PO120002R057-1	PO120003R057-1	PO120004R057-1	PO120005R057-1	PO120006R057-1
PO16	16	 90°	PO160001R057-1	PO160002R057-1	PO160003R057-1	PO160004R057-1	PO160005R057-1	PO160006R057-1
PO20	20		PO200001R057-1	PO200002R057-1	PO200003R057-1	PO200004R057-1	PO200005R057-1	PO200006R057-1

• Key removal position

Phoenix

Control switches

Panel mounting – Ø 22.5 hole



Central fixing Ø 22
□48
with red knob
058 058-1

Central fixing Ø 22
with black knob
and locking facility
059



Central fixing Ø 22
with red knob
and locking facility
060



SERIES	NOM. CURRENT AC21A AMP.	MARKING	3-POLE 2 WAFERS	4-POLE 2 WAFERS	MARKING	3-POLE 2 WAFERS	4-POLE 2 WAFERS
P012	12	□ 48	P0120003R058	P0120004R058	□ 48	P0120003R059	P0120004R059
P016	16		P0160003R058	P0160004R058		P0160003R059	P0160004R059
P020	20	90°	P0200003R058	P0200004R058		P0200003R059	P0200004R059
P012	12	□ 48	P0120003R058-1	P0120004R058-1	□ 48	P0120003R060	P0120004R060
P016	16		P0160003R058-1	P0160004R058-1		P0160003R060	P0160004R060
P020	20	90°	P0200003R058-1	P0200004R058-1		P0200003R060	P0200004R060



Central fixing Ø 22
grey escutcheon,
black disc-type knob
with locking facility
for 3 padlocks
061 061-1

Central fixing Ø 22
yellow escutcheon,
red disc-type knob
with locking facility
for 3 padlocks
062 062-1



SERIES	NOM. CURRENT AC21A AMP.	MARKING	3-POLE 2 WAFERS	4-POLE 2 WAFERS	MARKING	3-POLE 2 WAFERS	4-POLE 2 WAFERS
P012	12	□ 67	P0120003R061	P0120004R061	□ 67	P0120003R062	P0120004R062
P016	16		P0160003R061	P0160004R061		P0160003R062	P0160004R062
P020	20	90°	P0200003R061	P0200004R061	90°	P0200003R062	P0200004R062
P012	12	□ 67	P0120003R061-1	P0120004R061-1	□ 67	P0120003R062-1	P0120004R062-1
P016	16		P0160003R061-1	P0160004R061-1		P0160003R062-1	P0160004R062-1
P020	20	90°	P0200003R061-1	P0200004R061-1	90°	P0200003R062-1	P0200004R062-1

Phoenix

Control switches

Base-DIN rail mounting



TECHNO-CONTROL EQUIPMENT



Door interlock knob with locking facility **005**



Red door interlock knob with locking facility **006**

SERIES	MARKING	3-POLE 2 WAFERS	4-POLE 2 WAFERS	MARKING	3-POLE 2 WAFERS	4-POLE 2 WAFERS
PO12	<input type="checkbox"/> 48 <input type="checkbox"/>	PO120003B005	PO120004B005	<input type="checkbox"/> 48 <input type="checkbox"/>	PO120003B006	PO120004B006
PO16		PO160003B005	PO160004B005		PO160003B006	PO160004B006
PO20	90°	PO200003B005	PO200004B005	90°	PO200003B006	PO200004B006



Door interlock grey escutcheon, black disc-type knob with locking facility for 3 padlocks **011 011-A**



Door interlock yellow escutcheon, red disc-type knob with locking facility for 3 padlocks **012 012-2**

SERIES	MARKING	3-POLE 2 WAFERS	4-POLE 2 WAFERS	MARKING	3-POLE 2 WAFERS	4-POLE 2 WAFERS
PO12	<input type="checkbox"/> 67 <input type="checkbox"/>	PO120003B011	PO120004B011	<input type="checkbox"/> 67 <input type="checkbox"/>	PO120003B012	PO120004B012
PO16		PO160003B011	PO160004B011		PO160003B012	PO160004B012
PO20	90°	PO200003B011	PO200004B011	90°	PO200003B012	PO200004B012
PO12	<input type="checkbox"/> 67 <input type="checkbox"/>	PO120003B011-A	PO120004B011-A	<input type="checkbox"/> 67 <input type="checkbox"/>	PO120003B012-2	PO120004B012-2
PO16		PO160003B011-A	PO160004B011-A		PO160003B012-2	PO160004B012-2
PO20	90°	PO200003B011-A	PO200004B011-A	90°	PO200003B012-2	PO200004B012-2

Phoenix

Control switches

Base-DIN rail mounting



Installation in 46mm
standardised enclosures
black knob
027

SERIES	MARKING	1-POLE 1 WAFER	2-POLE 1 WAFER	3-POLE 2 WAFERS	4-POLE 2 WAFERS	5-POLE 3 WAFERS	6-POLE 3 WAFERS
P012	□ 52,5X45	P0120001D027	P0120002D027	P0120003D027	P0120004D027	P0120005D027	P0120006D027
P016	□ 90°	P0160001D027	P0160002D027	P0160003D027	P0160004D027	P0160005D027	P0160006D027

Base-DIN rail mounting with central fixing Ø 22



Door interlock
central fixing Ø 22
grey escutcheon,
black disc-type knob
063 063-1



Door interlock
central fixing Ø 22
yellow escutcheon,
red disc-type knob
064 064-1

SERIES	MARKING	3-POLE 2 WAFERS	4-POLE 2 WAFERS	MARKING	3-POLE 2 WAFERS	4-POLE 2 WAFERS
P012	■	P0120003B063	P0120004B063	■	P0120003B063-1	P0120004B063-1
P016	063	P0160003B063	P0160004B063	063-1	P0160003B063-1	P0160004B063-1
P020	□ 67	P0200003B063	P0200004B063	□ 67	P0200003B063-1	P0200004B063-1
P012	□ 90°	P0120003B064	P0120004B064	□ 90°	P0120003B064-1	P0120004B064-1
P016	064	P0160003B064	P0160004B064	064-1	P0160003B064-1	P0160004B064-1
P020		P0200003B064	P0200004B064		P0200003B064-1	P0200004B064-1

Phoenix

Line changeover switches

Panel and Ø 22.5 hole mounting



TECHNO-CONTROL EQUIPMENT



Standard control knob

001 □ 48

007 □ 64



Central fixing Ø 22 black knob

□ 48 056

SERIES	NOM. CURRENT AC21A AMP.	MARKING	1-POLE 1 WAFER	2-POLE 1 WAFER	3-POLE 2 WAFERS	4-POLE 2 WAFERS
P012	12		P0120008R001	P0120009R001	P0120010R001	P0120011R001
P016	16		P0160008R001	P0160009R001	P0160010R001	P0160011R001
P020	20		P0200008R001	P0200009R001	P0200010R001	P0200011R001
C025	25		C0250008R001	C0250009R001	C0250010R001	C0250011R001
C032	32		C0320008R001	C0320009R001	C0320010R001	C0320011R001
C040	40		C0400008R001	C0400009R001	C0400010R001	C0400011R001
P012	12		P0120008R056	P0120009R056	P0120010R056	P0120011R056
P016	16		P0160008R056	P0160009R056	P0160010R056	P0160011R056
P020	20		P0200008R056	P0200009R056	P0200010R056	P0200011R056
P012	12		P0120008R007	P0120009R007	P0120010R007	P0120011R007
P016	16		P0160008R007	P0160009R007	P0160010R007	P0160011R007
P020	20		P0200008R007	P0200009R007	P0200010R007	P0200011R007
C025	25		C0250008R007	C0250009R007	C0250010R007	C0250011R007
C032	32		C0320008R007	C0320009R007	C0320010R007	C0320011R007
C040	40		C0400008R007	C0400009R007	C0400010R007	C0400011R007



Round escutcheon

013 ø 59

014 ø 52



Black knob only

018

040

SERIES	NOM. CURRENT AC21A AMP.	MARKING	1-POLE 1 WAFER	2-POLE 1 WAFER	3-POLE 2 WAFERS	4-POLE 2 WAFERS
P012	12		P0120008R013	P0120009R013	P0120010R013	P0120011R013
P016	16		P0160008R013	P0160009R013	P0160010R013	P0160011R013
P020	20		P0200008R013	P0200009R013	P0200010R013	P0200011R013
P012	12		P0120008R014	P0120009R014	P0120010R014	P0120011R014
P016	16		P0160008R014	P0160009R014	P0160010R014	P0160011R014
P020	20		P0200008R014	P0200009R014	P0200010R014	P0200011R014
P012	12		P0120008R018	P0120009R018	P0120010R018	P0120011R018
P016	16		P0160008R018	P0160009R018	P0160010R018	P0160011R018
P020	20		P0200008R018	P0200009R018	P0200010R018	P0200011R018
C025	25		C0250008R040	C0250009R040	C0250010R040	C0250011R040
C032	32		C0320008R040	C0320009R040	C0320010R040	C0320011R040
C040	40		C0400008R040	C0400009R040	C0400010R040	C0400011R040

Phoenix

Motor changeover switches

Panel and Ø 22.5 hole mounting



Standard control knob

001 □ 48

007 □ 64



Central fixing Ø 22
black knob

056 □ 48

REVERSING SWITCHES

SERIES	NOM. CURRENT AC21A AMP.	MARKING	MARKING			
			3-POLE 3 WAFERS 45°	3-POLE RETRACTIVE 3 WAFERS 45°	FOR SINGLE-PHASE MOTORS WITH CENTRIFUGAL CUT-OUT 3 WAFERS 45°	FOR SINGLE-PHASE MOTORS WITH AUXILIARY PHASE 3 WAFERS 45°
P012	12	001	PO120012R001	PO120013R001	PO120016R001	PO120018R001
P016	16		PO160012R001	PO160013R001	PO160016R001	PO160018R001
P020	20		PO200012R001	PO200013R001	PO200016R001	PO200018R001
C025	25		C0250012R001	C0250013R001	C0250016R001	C0250018R001
C032	32	056	C0320012R001	C0320013R001	C0320016R001	C0320018R001
C040	40		C0400012R001	C0400013R001	C0400016R001	C0400018R001
P012	12		PO120012R056	PO120013R056	PO120016R056	PO120018R056
P016	16		PO160012R056	PO160013R056	PO160016R056	PO160018R056
P020	20	007	PO200012R056	PO200013R056	PO200016R056	PO200018R056
P012	12		PO120012R007	PO120013R007	PO120016R007	PO120018R007
P016	16		PO160012R007	PO160013R007	PO160016R007	PO160018R007
P020	20		PO200012R007	PO200013R007	PO200016R007	PO200018R007
C025	25	007	C0250012R007	C0250013R007	C0250016R007	C0250018R007
C032	32		C0320012R007	C0320013R007	C0320016R007	C0320018R007
C040	40		C0400012R007	C0400013R007	C0400016R007	C0400018R007

Phoenix

Motor changeover switches

Panel and Ø 22.5 hole mounting



TECHNO-CONTROL EQUIPMENT



Standard control knob

001 □ 48

007 □ 64



Central fixing Ø 22 black knob

056 □ 48

2-SPEED SWITCH

STAR DELTA SWITCH

SWITCH

3-POLE DAHLANDER
4 WAFERS

4 WAFERS

FOR SINGLE-PHASE MOTORS WITH AUXILIARY PHASE
2 WAFERS

MARKING

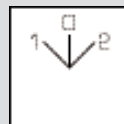

45°

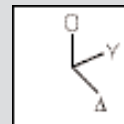

60°



45°

SERIES	NOM. CURRENT AC21A AMP.	MARKING	MARKING	2-SPEED SWITCH 3-POLE DAHLANDER 4 WAFERS	STAR DELTA SWITCH 4 WAFERS	SWITCH FOR SINGLE-PHASE MOTORS WITH AUXILIARY PHASE 2 WAFERS	
P012	12	<div style="display: flex; align-items: center;"> <div style="border: 1px solid black; width: 40px; height: 40px; margin-right: 5px;"></div> <div style="text-align: center;">48</div> <div style="border: 1px solid black; width: 40px; height: 40px; margin-left: 5px;"></div> </div>	001	P0120014R001	P0120015R001	P0120017R001	
P016	16		P0160014R001	P0160015R001	P0160017R001		
P020	20		P0200014R001	P0200015R001	P0200017R001		
C025	25		P0250014R001	C0250015R001	C0250017R001		
C032	32		P0320014R001	C0320015R001	C0320017R001		
C040	40		P0400014R001	C0400015R001	C0400017R001		
P012	12		<div style="display: flex; align-items: center;"> <div style="border: 1px solid black; width: 40px; height: 40px; margin-right: 5px;"></div> <div style="text-align: center;">64</div> <div style="border: 1px solid black; width: 40px; height: 40px; margin-left: 5px;"></div> </div>	056	P0120014R056	P0120015R056	P0120017R056
P016	16			P0160014R056	P0160015R056	P0160017R056	
P020	20			P0200014R056	P0200015R056	P0200017R056	
P012	12			P0120014R007	P0120015R007	P0120017R007	
P016	16	P0160014R007		P0160015R007	P0160017R007		
P020	20	P0200014R007		P0200015R007	P0200017R007		
C025	25	P0250014R007		C0250015R007	C0250017R007		
C032	32	P0320014R007		C0320015R007	C0320017R007		
C040	40	P0400014R007		C0400015R007	C0400017R007		

Phoenix

Motor changeover switches

Panel mounting





Round
escutcheon
013 ø 59
014 ø 52



Black
knob only
018
040

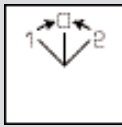
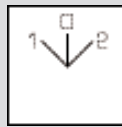
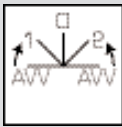

REVERSING SWITCHES

SERIES	NOM. CURRENT AC21A AMP.	MARKING	MARKING	3-POLE 3 WAFERS	3-POLE RETRACTIVE 3 WAFERS	FOR SINGLE-PHASE MOTORS WITH CENTRIFUGAL CUT-OUT 3 WAFERS	FOR SINGLE-PHASE MOTORS WITH AUXILIARY PHASE 3 WAFERS
				 45°	 45°	 45°	 45°
P012	12		013	P0120012R013	P0120013R013	P0120016R013	P0120018R013
P016	16			P0160012R013	P0160013R013	P0160016R013	P0160018R013
P020	20			P0200012R013	P0200013R013	P0200016R013	P0200018R013
P012	12			P0120012R014	P0120013R014	P0120016R014	P0120018R014
P016	16	014	014	P0160012R014	P0160013R014	P0160016R014	P0160018R014
P020	20			P0200012R014	P0200013R014	P0200016R014	P0200018R014
P012	12			P0120012R018	P0120013R018	P0120016R018	P0120018R018
P016	16			P0160012R018	P0160013R018	P0160016R018	P0160018R018
P020	20	018	018	P0200012R018	P0200013R018	P0200016R018	P0200018R018
C025	25			C0250012R040	C0250013R040	C0250016R040	C0250018R040
C032	32			C0320012R040	C0320013R040	C0320016R040	C0320018R040
C040	40			C0400012R040	C0400013R040	C0400016R040	C0400018R040

2-SPEED SWITCH

STAR DELTA SWITCH

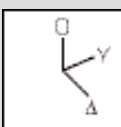
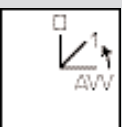
SWITCH

SERIES	NOM. CURRENT AC21A AMP.	MARKING	MARKING	3-POLE DAHLANDER 4 WAFERS	4 WAFERS	FOR SINGLE-PHASE MOTORS WITH AUXILIARY PHASE 2 WAFERS
				 45°	 60°	 45°
P012	12		013	P0120014R013	P0120015R013	P0120017R013
P016	16			P0160014R013	P0160015R013	P0160017R013
P020	20			P0200014R013	P0200015R013	P0200017R013
P012	12			P0120014R014	P0120015R014	P0120017R014
P016	16	014	014	P0160014R014	P0160015R014	P0160017R014
P020	20			P0200014R014	P0200015R014	P0200017R014
P012	12			P0120014R018	P0120015R018	P0120017R018
P016	16			P0160014R018	P0160015R018	P0160017R018
P020	20	018	018	P0200014R018	P0200015R018	P0200017R018
C025	25			C0250014R040	C0250015R040	C0250017R040
C032	32			C0320014R040	C0320015R040	C0320017R040
C040	40			C0400014R040	C0400015R040	C0400017R040

Phoenix

Instrumentation switches - Changeover without off switches - Step switches
Panel and Ø 22.5 hole mounting



TECHNO-CONTROL EQUIPMENT



Standard control knob
001 48
007 64



Central fixing Ø 22 black knob
056 48

SERIES	NOM. CURRENT AC21A AMP.	MARKING	MARKING	AMMETER		VOLTMETER					
				1-POLE FOR 3 CTS 3 WAFERS	3-PHASE TO NEUTRAL 2 WAFERS	PHASE TO PHASE 2 WAFERS	PHASE TO PHASE 2 CIRCUITS 4 WAFERS				
				90°	45°	45°	45°				
PO12	12		001	PO120019R001	PO120020R001	PO120021R001	PO120022R001				
PO16	16			PO160019R001	PO160020R001	PO160021R001	PO160022R001				
PO20	20			PO200019R001	PO200020R001	PO200021R001	PO200022R001				
PO12	12			056	001	PO120019R056	PO120020R056	PO120021R056	PO120022R056		
PO16	16					PO160019R056	PO160020R056	PO160021R056	PO160022R056		
PO20	20					PO200019R056	PO200020R056	PO200021R056	PO200022R056		
PO12	12					007	001	PO120019R007	PO120020R007	PO120021R007	PO120022R007
PO16	16							PO160019R007	PO160020R007	PO160021R007	PO160022R007
PO20	20							PO200019R007	PO200020R007	PO200021R007	PO200022R007

SERIES	NOM. CURRENT AC21A AMP.	MARKING	MARKING	VOLTMETER		CHANGEOVER WITHOUT OFF SWITCH						
				PHASE TO PHASE 3 WAFERS	PHASE TO PHASE - 1 PHASE TO NEUTRAL 3 WAFERS	SINGLE POLE 1 WAFER	DOUBLE POLE 2 WAFERS	3-POLE 3 WAFERS				
				45°	45°							
PO12	12		001	PO120023R001	PO120024R001	PO120025R001	PO120026R001	PO120027R001				
PO16	16			PO160023R001	PO160024R001	PO160025R001	PO160026R001	PO160027R001				
PO20	20			PO200023R001	PO200024R001	PO200025R001	PO200026R001	PO200027R001				
PO12	12			056	001	PO120023R056	PO120024R056	PO120025R056	PO120026R056	PO120027R056		
PO16	16					PO160023R056	PO160024R056	PO160025R056	PO160026R056	PO160027R056		
PO20	20					PO200023R056	PO200024R056	PO200025R056	PO200026R056	PO200027R056		
PO12	12					007	001	PO120023R007	PO120024R007	PO120025R007	PO120026R007	PO120027R007
PO16	16							PO160023R007	PO160024R007	PO160025R007	PO160026R007	PO160027R007
PO20	20							PO200023R007	PO200024R007	PO200025R007	PO200026R007	PO200027R007

Phoenix

Step switches - Panel and Ø 22.5 hole mounting

Instrumentation switches - Base-DIN rail mounting



Standard control knob
Black knob

001 □ 48

007 □ 64



Central fixing Ø 22
black knob





056 □ 48

Installation in standard
46mm standardised
enclosures black knob

027



STEP WITH OFF SWITCH

SERIES	NOM. CURRENT AC21A AMP.	MARKING	MARKING	STEP WITH OFF SWITCH		
				2-STEP SINGLE POLE 1 WAFER	3-STEP SINGLE POLE 2 WAFERS	4-STEP SINGLE POLE 2 WAFERS
						
				45°	45°	45°
P012	12		001	P0120028R001	P0120029R001	P0120030R001
P016	16			P0160028R001	P0160029R001	P0160030R001
P020	20			P0200028R001	P0200029R001	P0200030R001
P012	12			P0120028R056	P0120029R056	P0120030R056
P016	16			P0160028R056	P0160029R056	P0160030R056
P020	20			P0200028R056	P0200029R056	P0200030R056
P012	12			P0120028R007	P0120029R007	P0120030R007
P016	16			P0160028R007	P0160029R007	P0160030R007
P020	20			P0200028R007	P0200029R007	P0200030R007

AMMETER

1-POLE
FOR 3 CTS
3 WAFERS

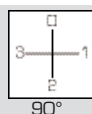

90°

VOLTMETER

PHASE
TO PHASE
3 WAFERS

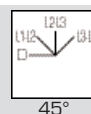

45°

PHASE TO PHASE-PHASE
TO NEUTRAL
3 WAFERS

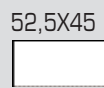

45°

SERIES	NOM. CURRENT AC21A AMP.	MARKING	MARKING	AMMETER	VOLTMETER	VOLTMETER
				1-POLE FOR 3 CTS 3 WAFERS	PHASE TO PHASE 3 WAFERS	PHASE TO PHASE-PHASE TO NEUTRAL 3 WAFERS
P012	12	52,5X45 	001	P0120019D027	P0120021D027	P0120023D027
P016	16			P0160019D027	P0160021D027	P0160023D027

MADE TO ORDER SWITCHES



CX25 - CX32 - CX40 series
Made from the C25 - C32 - C40 series
With IP10 terminals
For multiple connections

P012 - P016 - P020 series
with flat fast on terminals
No. 1 6.3x0.8 terminal
No. 2 2.8x0.8 terminal

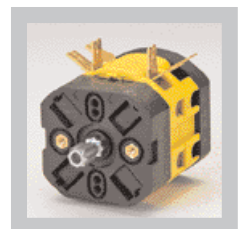

Phoenix

Cam switches

Accessories



TECHNO-CONTROL EQUIPMENT

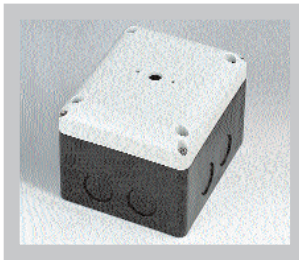

BF1/2NGO

Moulded wall-mounted enclosure for CO12-CO16-CO20 R series. Provision for the installation of the switch on the front

Max 3 wafers IP65
Black box - RAL 7035
grey front cover
Dimensions 120x100x82 mm
No. 8 knock-outs

Moulded wall-mounted enclosure for CO12-CO16-CO20 R series
Provision for the installation of the switch on the side

For Ref. O18 controls
Max 3 wafers IP65
Black box - RAL 7035
grey front cover
Dimensions 120x100x82 mm
No. 8 knock-outs

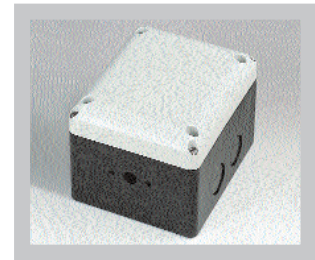

BL1/ONGO

SHORT HANDLE			LONG HANDLE			PADLOCKABLE HANDLE			ROUND KNOB		
REF. NO.	COLOUR	CAM	REF. NO.	COLOUR	REF. NO.	COLOUR	CAM	Ø	REF. NO.	COLOUR	
20402023	Black	□ 6	20402025	Black	20401090	Black	□ 5 *	34	20402027	Black	
		□ 6	20402026	Red			□ 6 *	34	20402020	Black	
20402024	Red	□ 6 *	20402172	Black	20401091	Red	□ 5 *	40	20402171	Black	
		□ 6 *	20402173	Red			□ 6 *	40	20402170	Black	

IP65 SEAL		IP65 SEAL		SHAFT		ROUND KNOB Ø 30	
For control knob: O13-O14-O18		For control knob: O40		For door interlock			
PO12-PO16-PO20 Series	CO25-CO32-CO40 Series	L 185 mm	20401089	PO12-PO16 Series	Control knob O15		
28000012	15000015	L 300 mm	20401164	20402050	Black		

Ø 65 PROTECTION		Ø 65 PROTECTION ADAPTER		FLAT FAST ON TERMINALS	
From 1 up to 3 wafers PO12 - PO16 - PO20 series	Dimensions = 2 wafers				
11706031	11702038				
* Installation with adapter					

PO12 - PO16 - PO20 Series
FLAT 11708340 A 30° 11708341

Phoenix

Technical data

Electrical characteristics

EN 60947-3 CHARACTERISTICS			P012	P016	P020	C025	C032	C040
Rated operating voltage U _e	V		690	690	690	690	690	690
Rated insulation voltage U _i	V		690	690	690	690	690	690
Rated impulse voltage U _{imp}	kV		4	4	4	6	6	6
Rated thermal current I _{th}	A		12	16	20	32	40	50
Rated thermal current enclosed I _{the}	A		12	16	20	25	32	40
Frequency	Hz		50/60	50/60	50/60	50/60	50/60	50/60
RATED OPERATING CURRENT I_e: alternate current								
AC-21A Switching resistive loads with light overloads	690V	A	12	16	20	25	32	40
AC-22A Switching mixed resistive and inductive loads with light overloads	690V	A	12	16	20	25	32	40
AC-23A Periodic switching of motors	Single-phase - 2-pole	110V A/kW	12/1,1	14/1,5	18/2	20/1,5	25/2,2	35/3
		230V A/kW	12/2,2	14/3	18/4	25/4	30/5,5	35/6,5
		230V A/kW	10/3	13/4	16/5	25/7,5	30/9	35/11
	3-phase - 3-pole	400V A/kW	10/5,5	13/7,5	16/9	22/11	27/15	32/18,5
		500V A/kW	10/7,5	14/10	16/11	22/15	27/18,5	32/22
		690V A/kW	10/7,5	14/10	16/12,5	16/15	20/18,5	25/22
AC3 Starting of cage motors (interruption while running)	Single-phase - 2-pole	110V A/kW	10/0,75	12/1,1	16/1,5	16/1,1	20/1,5	30/2,5
		230V A/kW	10/2	12/2,2	16/3,5	20/3,7	25/4	30/5,5
		230V A/kW	8/2,2	10/3	12/4	18/5,5	23/7,5	27/9
	3-phase - 3-pole	400V A/kW	8/4	10/5	10/6	16/7,5	20/11	27/15
		500V A/kW	8/5	10/7,5	12/8	16/11	20/15	27/18,5
		690V A/kW	6/5,5	8/7,5	10/9	12/11	16/15	20/18,5
RATED OPERATING CURRENT I_e: direct current								
DC-21A Switching resistive loads with light overloads (1 phase)	50V (1 polo)	A	10	12	16	20*	25*	32*
DC-22A Switching mixed resistive and inductive loads with light overloads (1 phase)	30V (1 polo)	A	8	10	12	16*	20*	25*
AC-23A Periodic switching of motors (cosφ 0.45)	230V	A	128	128	128	280	280	280
	400V	A	128	128	128	256	256	256
	500V	A	128	128	128	256	256	256
	690V	A	128	128	128	200	200	200
Power dissipation for each phase	W		0,3*	0,35*	0,4*	-	-	-
SHORT CIRCUIT CHARACTERISTICS								
Rated short-time short circuit withstand current I _{cw} (1s)	A		300	300	300	500	500	500
Rated short circuit making capacity I _{cm}	A		1200	1200	1200	2840	2840	2840
Conditional rated short circuit withstand current	kA		5	5	5	10	10	10
Fuse rating gG	690V	A	20	20	20	40*	40*	40*
UL 508 CHARACTERISTICS								
General Use	600V ac	A	12	16	20	25	32	40
Standard motors load	Single-phase - 2-pole	120V ac HP(FLA)	0,5 (9,8)	1 (16)	1,5 (20)	1,5(20)	2 (24)	3 (34)
		240V ac HP(FLA)	1 (8)	1,5 (10)	2 (12)	3 (17)	5 (28)	5 (28)
		200V ac HP(FLA)	1,5 (9)	3 (14,4)	5 (22,8)	7,5 (25,3)	7,5 (25,3)	10 (32,2)
		240V ac HP(FLA)	3 (9,6)	5 (15,2)	5 (15,2)	7,5 (22)	7,5 (22)	10 (28)
	3-phase - 3-pole	480V ac HP(FLA)	5 (7,6)	7,5 (11)	10 (14)	15 (21)	20 (27)	20 (27)
		600V ac HP(FLA)	5 (6,1)	7,5 (9)	10 (11)	15 (17)	20 (22)	20 (22)

*Values not reported on the IMQ file

* Fuses gG 40A-500V

Phoenix

Technical data

General characteristics



TECHNO-CONTROL EQUIPMENT

Comply with		IEC947-3, EN60947-3, UL508							
		P012 - P016 - P020			C025 - C032 - C040				
Protection class	controls	EN60529			IP65				
	controls O13 - O14 - O18 - O40				IP40				
	terminals				IP20				
	cx. series terminals				IP10				
Material group	EN60947-1			II					
Pollution grade	EN60947-1			3					
Flammability	UL 94			VO: live parts					
Ambient temperature				Operating: -25 +55					
				Storage: -30 +70					
Climate withstand	IEC68 part 2-3			Hot damp					
	IEC68 part 2-30			Unsettled hot damp					
Terminal referencing				EN50013					
Terminals:									
Dimension	EN60947-1			A3		A5			
Terminal screw				M 3,5		M4			
Torque	EN60947-1			0,8 Nm (7,2 lb. in.)		1,2 Nm (10,6 lb. in.)			
	UL508			7,5 lb. in. (0,85 Nm)		12 lb in. (1,4 Nm)			
Capacity:									
n° 2 flexible conductors min/max	mm ²			1x0,75/4 - 2x0,75/2,5		2x2,5/10			
	AWG			16-12		14-6			
n° 2 solid conductors min/max	mm ²			1x0,75/4 - 2x0,75/2,5		2X2,5/10			
	AWG			16-12		14-6			
Contacts				Double gap contacts with positive opening action					
Opening angles				45° - 60° - 90°		30° - 45° - 60° - 90°			
Mechanical life at 120 operations per hour	mil./cycles			1		1			
Electrical life at 120 operations per hour	AC21	mil./cycles		1	0,75	0,75	1	0,75	0,5
CERTIFICATIONS									
CE mark - Europe				■	■	■	■	■	■
CUL Listed - USA and Canada				●	●	●	●	●	●
Istituto Marchio Qualità (IMQ) - Italy				●	●	●	●	●	●
CCC China				●	●	●	●	●	●
GOST-R Russia				●	●	●	●	●	●

■ Meets or exceed the minimum requirements ● Certified

Phoenix

Dimensions

Fixing details

PANEL MOUNTING

FIXING HOLES

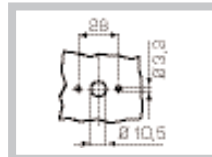

P012 - P016 - P020 SERIES

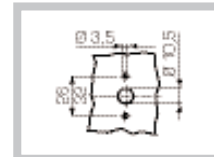

C012 - C016 - C020 SERIES

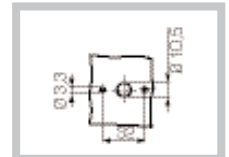

C025 - C032 - C040 SERIES

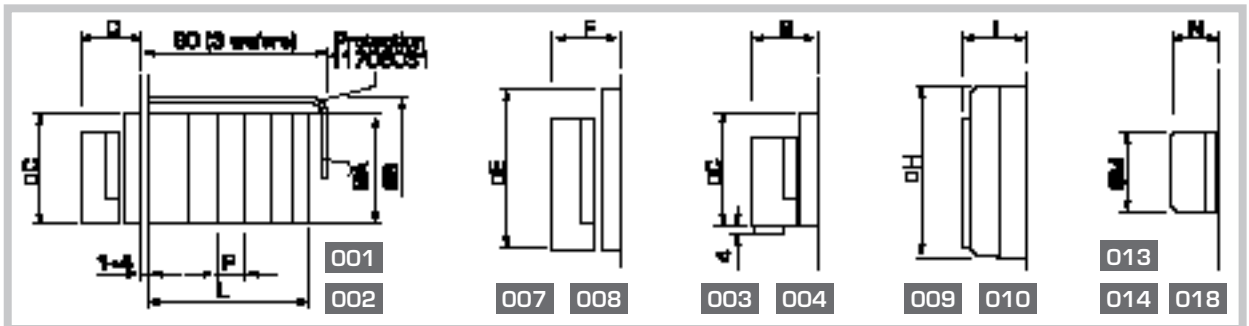

L x WAFERS No.

SERIES	1	2	3	4	5	6	P	A	B	C	D	E	H	I	M	N		
P012 - P016 - P020	39	51,7	64,4	77,1	89,8	102,5	12,7	45	63	48	30,2	64	30,2	35,2	67	30,2	34	18,8
C025 - C032 - C040	41,5	59	76,5	94	111,5	129	17,5	62	-	48	30,2	64	30,2	35,2	67	30,2	34	18,8

PANEL MOUNTED WITH 22.5 Ø HOLE

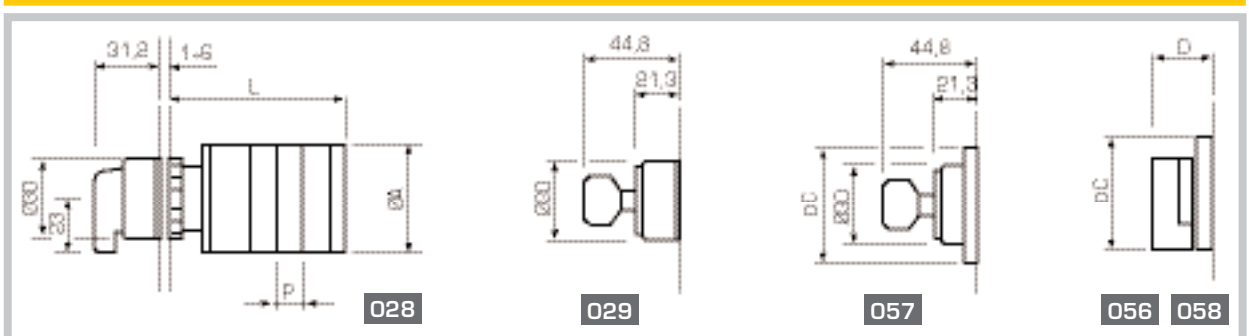

FIXING HOLE

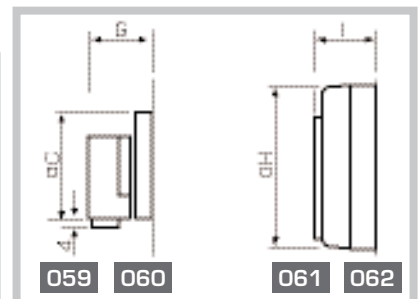
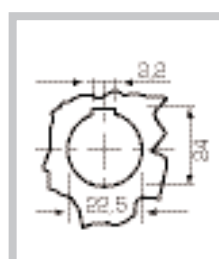

L x WAFERS No.

SERIES	1	2	3	4	5	6
P012 - P016 - P020	58,2	70,9	83,6	96,3	109	121,7

BASE MOUNTING FOR DOOR INTERLOCK

BASE MOUNTING - DOOR INTERLOCK

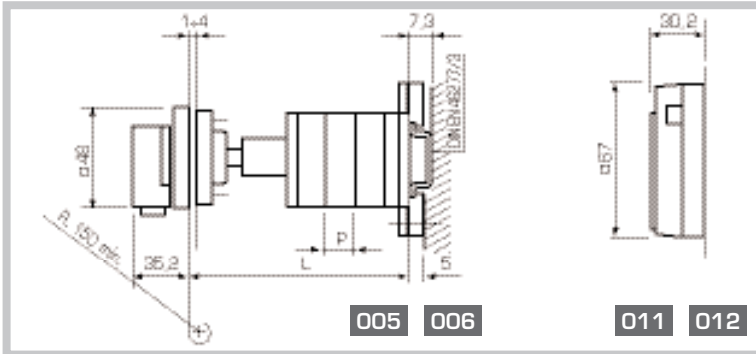

FIXING HOLES

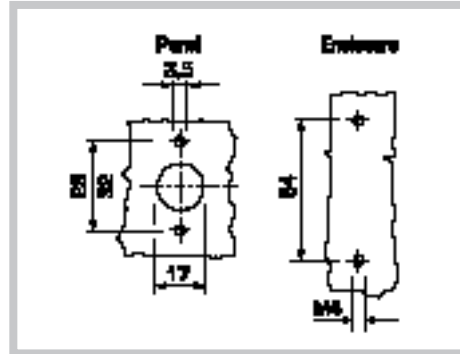

L x WAFERS No. WITH SHAFT AS STANDARD

SERIES		L x WAFERS No. WITH SHAFT AS STANDARD						P
		1	2	3	4	5	6	
P012 - P016 - P020	min	76,7	89,4	102,1	114,8	127,5	140,2	12,7
	max	134,7	147,4	160,1	172,8	185,5	198,2	

L x WAFERS No. WITH SHAFT EXTENSION (ref. No. 20401089)

	L x WAFERS No. WITH SHAFT EXTENSION (ref. No. 20401089)					
	1	2	3	4	5	6
min	76,7	89,4	102,1	114,8	127,5	140,2
max	234,7	247,4	260,1	272,8	285,5	298,2

BASE MOUNTING WITH 22.5 Ø HOLE - DOOR INTERLOCK

BASE MOUNTING - DOOR INTERLOCK

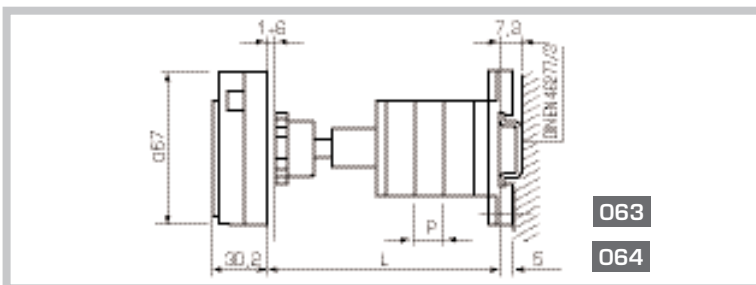

FIXING HOLES

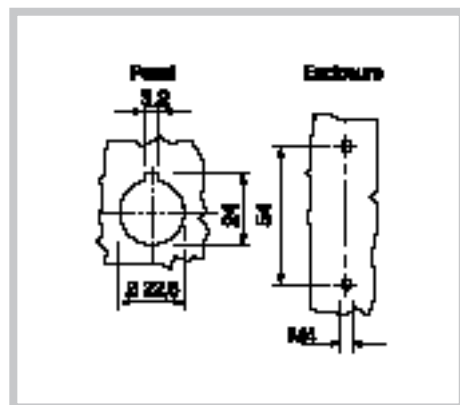

L x WAFERS No. WITH SHAFT AS STANDARD

SERIES		L x WAFERS No. WITH SHAFT AS STANDARD						P
		1	2	3	4	5	6	
P012 - P016 - P020	min	76,7	89,4	102,1	114,8	127,5	140,2	12,7
	max	134,7	147,4	160,1	172,8	185,5	198,2	

BASE MOUNTING - 46 mm STANDARD ENCLOSURES

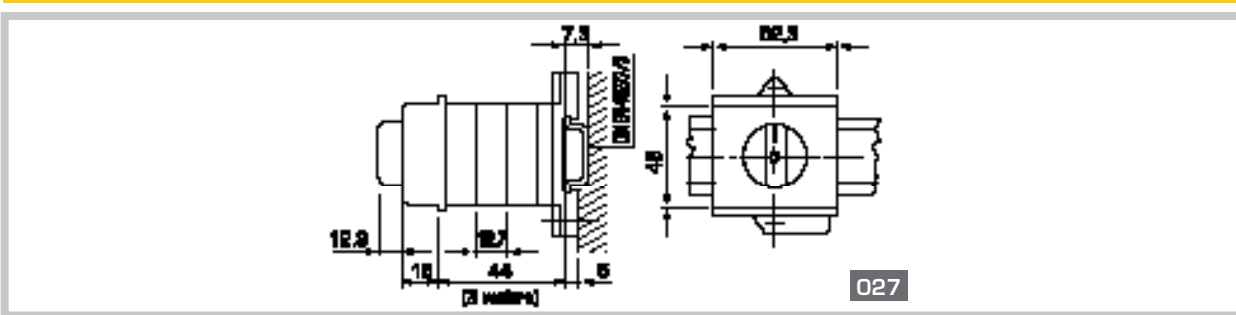

Phoenix

Cam switches

Circuit diagrams

SWITCHES

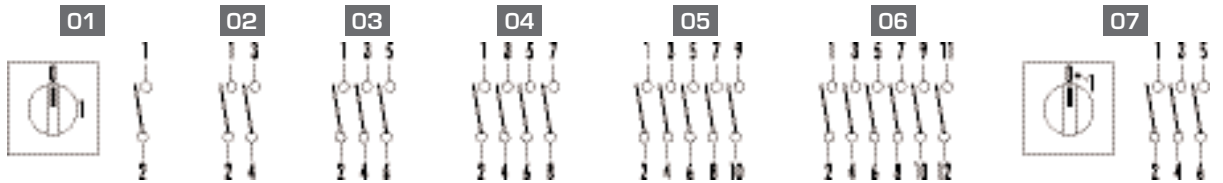

LINE CHANGEOVER SWITCHES



MOTOR CHANGEOVER SWITCHES

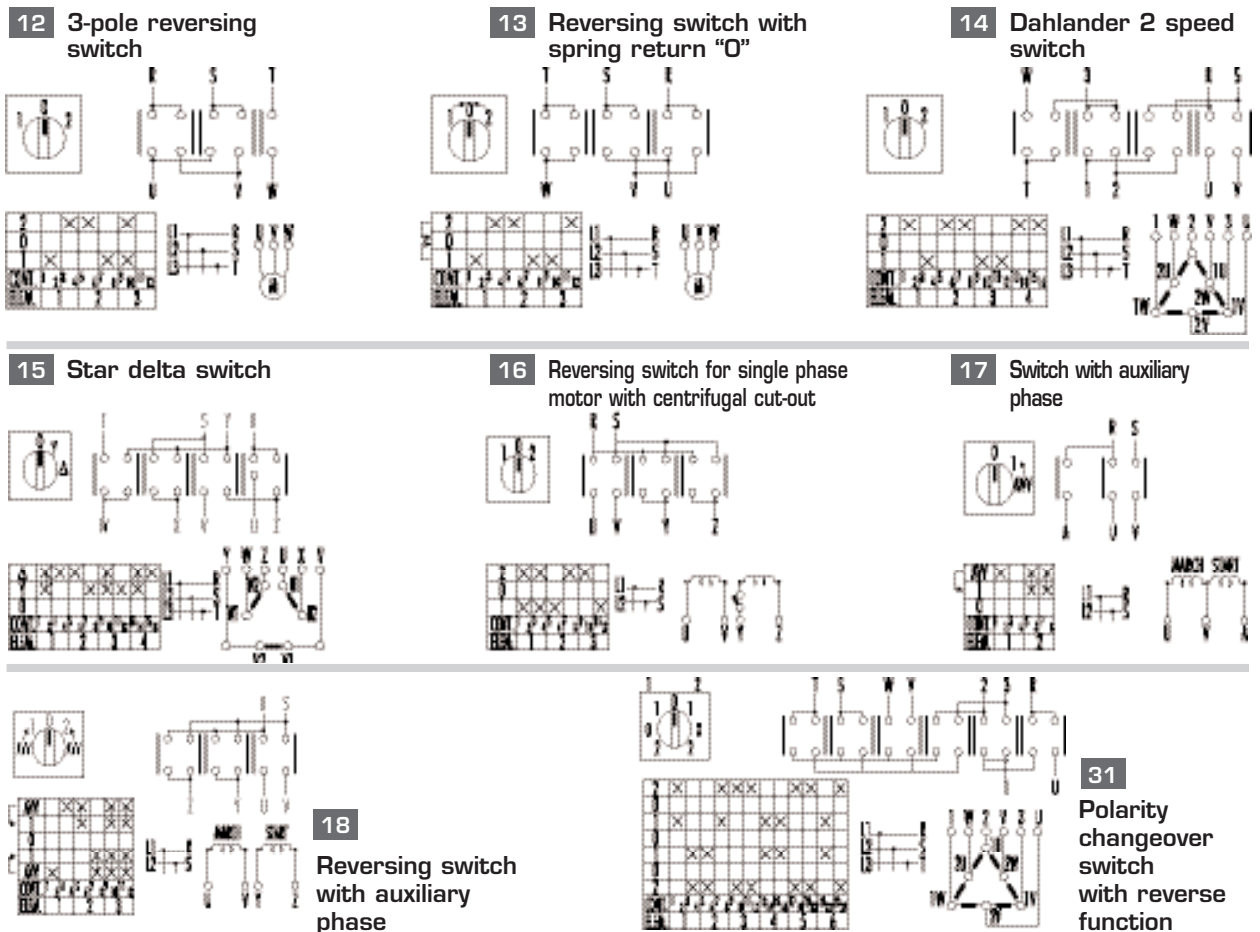

AMMETER CHANGEOVER SWITCHES

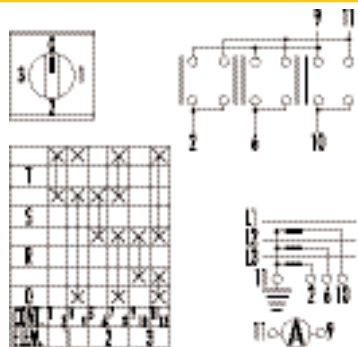

19 Single pole ammeter changeover switch for transformers

VOLTMETER CHANGEOVER SWITCHES

20 3-phase to neutral voltmeter changeover switch

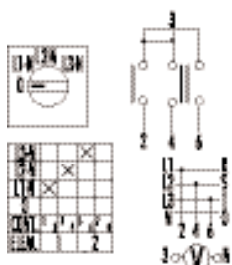

21 Phase to phase voltmeter changeover switch

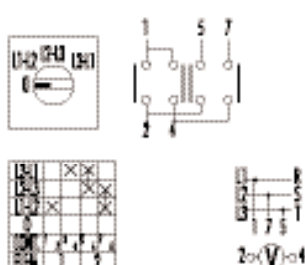

22 Phase to phase voltmeter changeover switch - 2 circuits

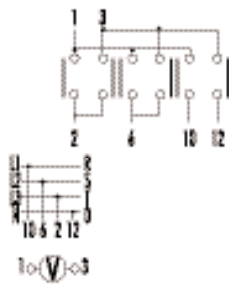
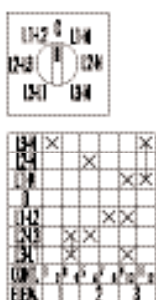
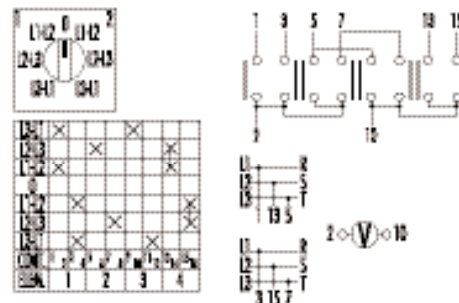

23 Phase to phase to neutral changeover switch

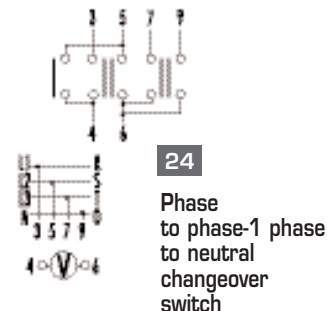
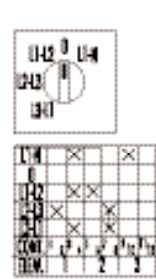

24 Phase to phase-1 phase to neutral changeover switch

2-WAY SWITCHES

25

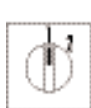

26



27



STEP WITH OFF SWITCHES

28

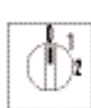

29

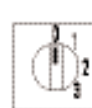

30

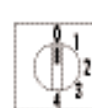

Phoenix

Cam switches

Special diagram on request

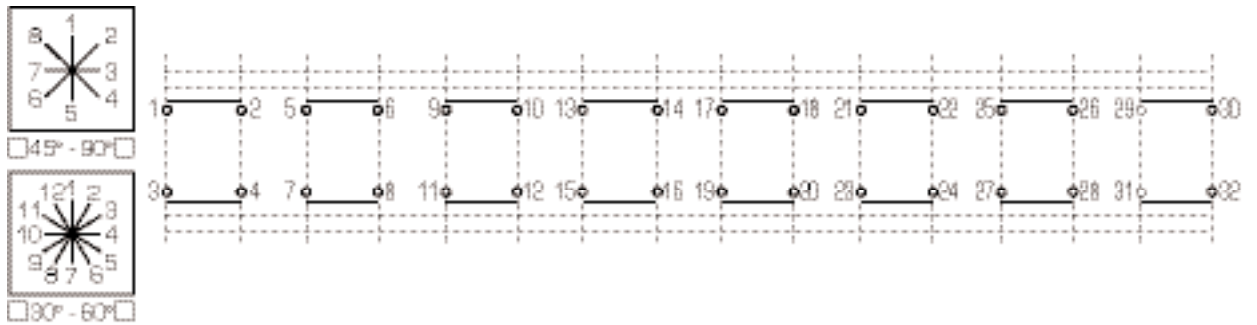

POS.	DESCRIPTION	POS.	DESCRIPTION
1		7	
2		8	
3		9	
4		10	
5		11	
6		12	

Water	Contact	Position
10	39-40	
10	37-38	
9	35-36	
9	33-34	
8	31-32	
8	29-30	
7	27-28	
7	25-26	
6	23-24	
6	21-22	
5	19-20	
5	17-18	
4	15-16	
4	13-14	
3	11-12	
3	9-10	
2	7-8	
2	5-6	
1	3-4	
1	1-2	

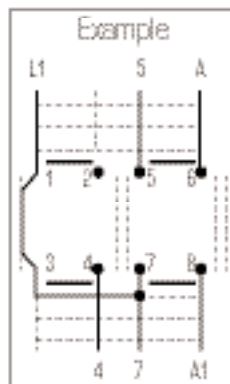

Water	Contact	Position
2	7-8	X
2	5-6	X-X
1	3-4	X-X
1	1-2	X

- Open contact
- Closed contact
- Break before make
- Contact closed: no interruption during change-over
- Spring return
- Make before break
- Open contact early make

Rated current Ie
Operational rated voltage Ue

Category	Amp/kw	Volt
<input type="checkbox"/> AC-21A	A	V
<input type="checkbox"/> AC-22A	A	V
<input type="checkbox"/> AC-23A	1Ph kW	V
	3Ph kW	V
<input type="checkbox"/> AC-3	1Ph kW	V
	3Ph kW	V

Series _____

Mounting:

- Panel mounting
- Base mounting
- DIN rail

Operating:

Notes:

Company _____

Contact Mr _____

Ph. _____
 Fax _____
 E-mail _____
 Quantity _____
 Due date _____
 Order No. _____

Regolus

Switch-disconnectors

Table of contents



TECHNO-CONTROL EQUIPMENT

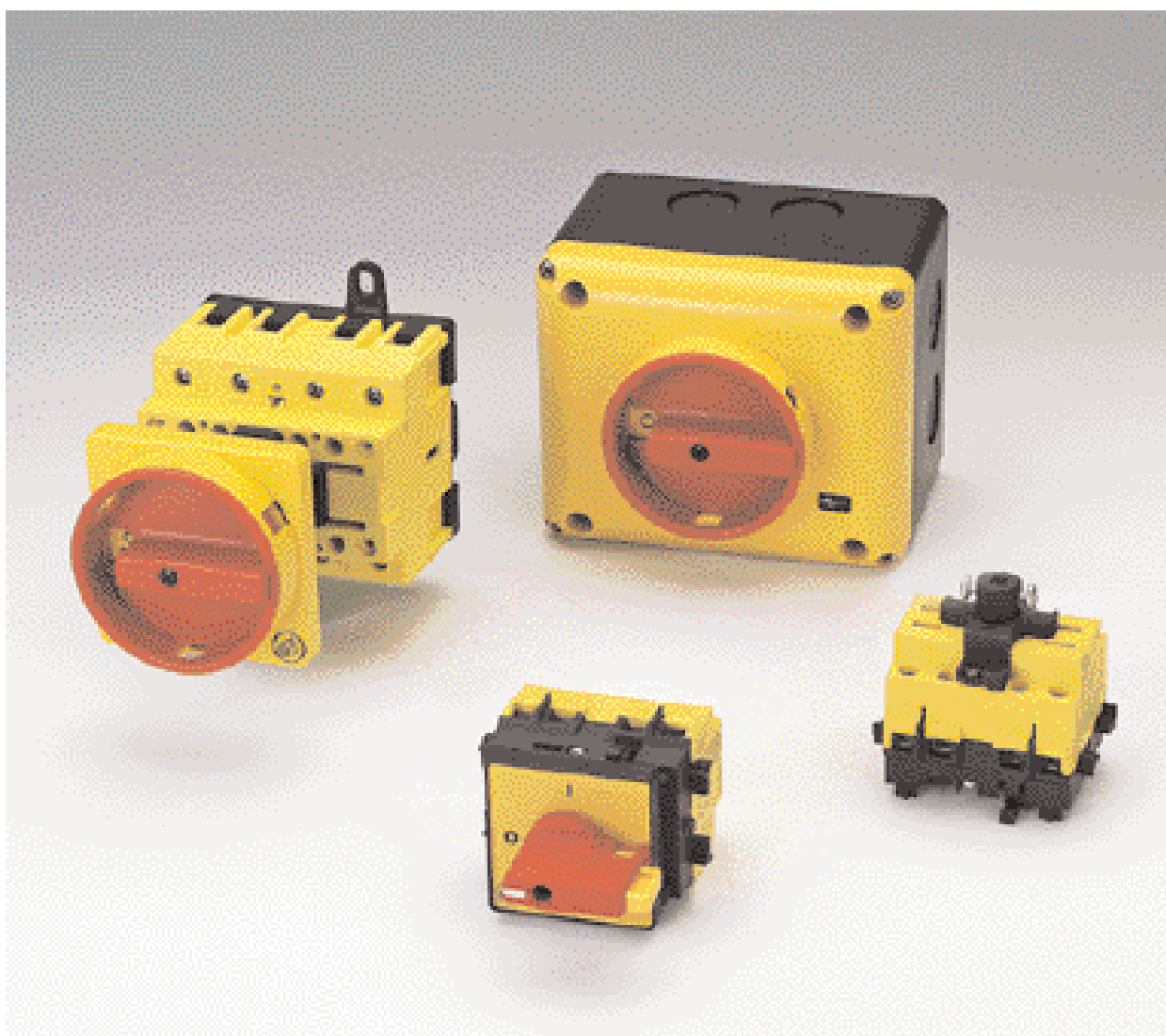

Current rating from 32 up to 100A. Panel, base and DIN rail mounted. Available in the 2, 3 and 4-pole version with central control knob and through shaft. 2 and 3-pole fuse holders for switch-disconnectors up to 32A.

TABLE OF CONTENTS

■ Switch-disconnectors	pag.36	■ Technical data	pag.40
■ Control knob type	pag.37	■ Assembly	pag.42
■ Enclosed installation	pag.38	■ Dimensions	pag.43
■ Accessories	pag.39		

Regolus

Switch-disconnectors

IP 20

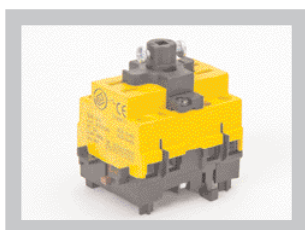

SE16
SE32

Base mounting B
For installation
on DIN-EN50022-35 rail
for door interlocks

SE63
SE80
SE100

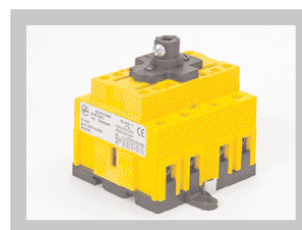

SERIES	AC AMP.		2-POLE		3-POLE		4-POLE	
	690V	400V	Diagram	Terminal	Diagram	Terminal	Diagram	Terminal
SE16	32	25		1L1 N 2T1 N		1L1 3L2 5L3 2T1 4T2 6T3		1L1 3L2 5L3 N 2T1 4T2 6T3 N
SE32	40	32						
SE63	63	50						
SE80	80	60						
SE100	100	67						

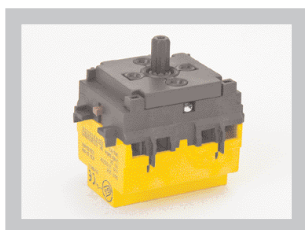

SE16
SE32

Panel
mounting R

SE63
SE80
SE100

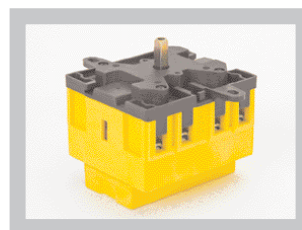

SERIES	AC AMP.		2-POLE		3-POLE		4-POLE	
	690V	400V	Diagram	Terminal	Diagram	Terminal	Diagram	Terminal
SE16	32	25		1L1 N 2T1 N		1L1 3L2 5L3 2T1 4T2 6T3		1L1 3L2 5L3 N 2T1 4T2 6T3 N
SE32	40	32						
SE63	63	50						
SE80	80	60						
SE100	100	67						

Regolus

Switch-disconnectors

IP65 Control knob





TECHNO-CONTROL EQUIPMENT

BASE MOUNTING CONTROL KNOBS FOR DOOR INTELLOCK

		
□ 48 ■	□ 48 ■	□ 67 ■
Standard control knob	Black knob with locking facility	Grey escutcheon, black disc-type knob with locking facility for 3 padlocks
SE16	SE16	SE16 SE63
		SE80
SE32	SE32	SE32 SE100
020/0001	005/0001	011/0001 041/0001 063/0001* 065/0001*

FOR ...B DEVICES



		
□ 48 ■	□ 48 ■	□ 67 ■
Red knob	Red knob locking facility	Yellow escutcheon, Red disc-type knob with locking facility for 3 padlocks
SE16	SE16	SE16 SE63
		SE80
SE32	SE32	SE32 SE100
030/0001	006/0001	012/0001 042/0001 064/0001* 066/0001*

* Central fixing version Ø 22,5

PANEL MOUNTING CONTROL KNOBS

		
□ 48 ■	□ 48 ■	□ 67 ■
Standard control knob	Black knob with locking facility	Grey escutcheon, black disc-type knob with locking facility for 3 padlocks
SE16	SE16	SE16 SE63
		SE80
SE32	SE32	SE32 SE100
001/0001	003/0001	009/0001 049/0001

FOR ...R DEVICES

		
□ 48 ■	□ 48 ■	□ 67 ■
Red knob	Red knob locking facility	Yellow escutcheon, Red disc-type knob with locking facility for 3 padlocks
SE16	SE16	SE16 SE63
		SE80
SE32	SE32	SE32 SE100
002/0001	004/0001	010/0001 050/0001

Regolus

Enclosed installation

Enclosed installation IP65

- Lid released when knob in O/OFF position only
- No. 8 knock-outs
- Heat resistant material

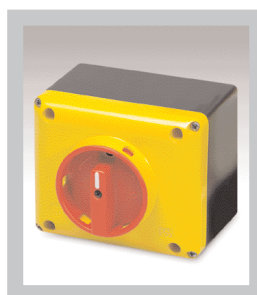

C10

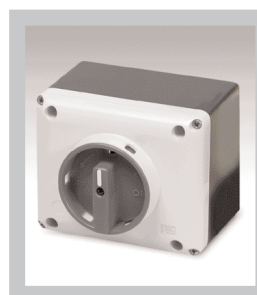

C09



C01

3-POLE

4-POLE

3-POLE

4-POLE

3-POLE

4-POLE

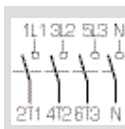

SERIES	AC-21A AMP. 690V		AC-23A AMP. 400V			
	32	25	32	25		
SE16	SE160003BC10	SE160004BC10	SE160003BC09	SE160004BC09	SE160003BC01	SE160004BC01
SE32	SE320003BC10	SE320004BC10	SE320003BC09	SE320004BC09	SE320003BC01	SE320004BC01

- Lid released when knob in O/OFF position only
- Provision for No. 2 M32 and No. 2 M40 cable glands
- Heat resistant material

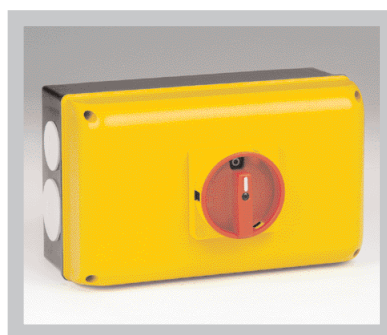

C41

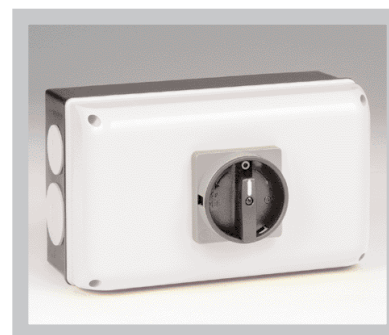

C42

3-POLE

4-POLE

3-POLE

4-POLE



SERIES	AC-21A AMP. 690V		AC-23A AMP. 400V	
	63	50	60	67
SE63	SE630003BC41	SE630004BC41	SE630003BC42	SE630004BC42
SE80	SE800003BC41	SE800004BC41	SE800003BC42	SE800004BC42
SE100	SE100003BC41	SE100004BC41	SE100003BC42	SE100004BC42

Regolus

Switch-disconnectors

Accessories



TECHNO-CONTROL EQUIPMENT

- Thermoplastic enclosure for SE 16-SE32 B BOX series
- IP65
- Dimensions
- Order also:
Shaft 11706237
Fixing plate 11814005

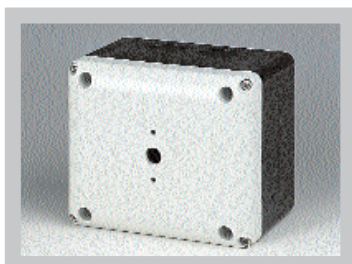

BF1/1NGO

- Thermoplastic enclosure for SE 16-SE32 R series
- Panel mounting



BF1/2NGO

- Aluminium enclosure for SE 16-SE32 R series 102x102x81
- IP65
- Sand finish
- No. 2 Ø 20.5 holes
- Lid □ 106

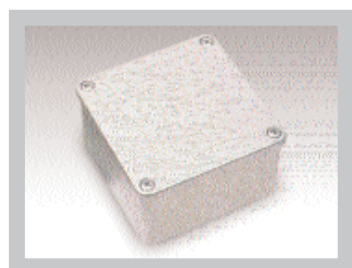

BFM/3ASO

- Fuse holder for SE 16-SE32 BOX series
- For 32A 10.3x38 max. fuses
- Terminal protection class IP20

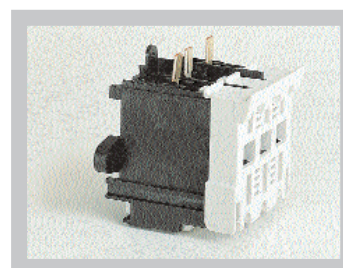

2-Pole **TF322**
3-Pole **TF323**

SHAFT FOR BF1/NGO ENCLOSURE

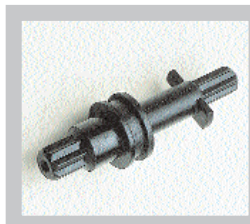

SE16-SE32 B Series
11706237

SHAFT EXTENSION □ 5 SERIES SE16-SE32

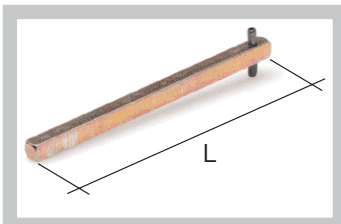

L 185 mm | 20401089
L 300 mm | 20401164

ENCLOSURE FIXING PLATE

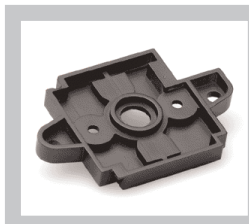

SE16-SE32 B Series
11814005

SHAFT EXTENSION □ 6 SERIES SE63-SE100

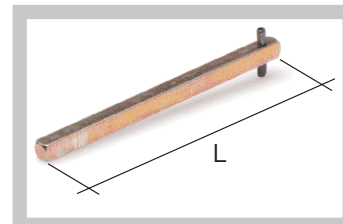

L 185 mm | 20900010
L 300 mm | 20900011

AUXILIARY CONTACTS

- SE16-SE32 Series
- IEC/EN 60947-5-1
- Ith 16A-690V ac
- AC15 6A-230V/4.5A-400V
- UL508 A600-Q600
- Order also:
Fixing plate 11814021
- No. 1 pc. for each contact



1 NC **PL004001**
1 NO **PL004002**

FIXING PLATE FOR AUXILIARY CONTACTS

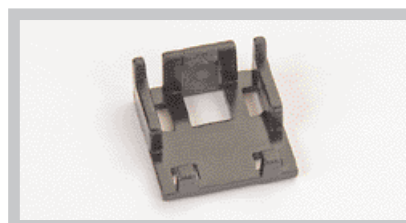

SE16-SE32 Series
11814021

Regolus

Technical data

Electrical characteristics

CHARACTERISTICS IEC/EN60947-3			SE16	SE32	SE63	SE80	SE100	
Rated operating voltage Ue	V		690*	690*	690	690	690	
Rated insulation voltage Ui	V		690*	690*	690	690	690	
Rated impulse withstand voltage Uimp	kV		4*	4*	8	8	8	
Rated thermal current Ith	A		(30*) 32	40*	63*	86*	100	
Rated thermal current enclosed Ithe	A		(30*) 32	40*	63*	86*	86	
Frequency	Hz		50	50	50	50	50	
RATED OPERATING CURRENT Ie: alternate current								
AC-21A Switching resistive loads with light overloads	690V	A	(30*) 32	(32*) 40	63*	80*	100	
AC-22A Switching mixed resistive and inductive loads with light overloads	500V	A	-	-	-	-	100	
	690V	A	(20*) 25	32*	63*	80*	86	
AC-23A Periodic switching of motors	3-phase - 3-pole	230V	A/kW	25/7.5	32/10	50/15	63/18.5	70/22
		400V	A/kW	25/15	32/18.5	50/30	60/33	67/37
		500V	A/kW	25/15	32/22	50/37	60/40	67/45
		690V	A/kW	(16A*) 20/18.5	25*/22	32/30	35/33	38/37
AC3 Starting of cage motors (interruption while running)	3-phase - 3-pole	230V	A/kW	22/7.5	30/9	40/11	50/15	60/18.5
		400V	A/Kw	22/11	30/15	40/22	50/25	55/30
		500V	A/kW	22/11	30/18,5	40/30	50/33	55/37
		690V	A/kW	(12A*) 22/11	(20A*) 22/18.5	25/22	27/25	32/30
AC-23A rated breaking capacity (cosφ 0.45)		110V	A/kW	256	256	560	560	560
		230V	A/kW	256	256	536	536	536
		230V	A/Kw	256	256	536	536	536
		400V	A/kW	200	200	304	304	304
SHORT-CIRCUIT CHARACTERISTICS								
Rated short-time short circuit withstand current Icw (1s)	A		400*	400*	1500	1500	1500	
Rated short circuit making capacity Icm	A		1500*	1500*	2840	2840	2840	
Conditional rated short circuit withstand current	kA		10*	10*	10*	10*	10	
Fuse rating gG	500V	A	-	-	-	-	100	
	690V	A	40*	40*	(80*) 63	80*	-	
UL508 CHARACTERISTICS								
General Use	600V ac	A	32	40	63	80	100	
Standard motors load	1-phase - 2-pole	120V ac HP(FLA)	1.5 (20)	2 (24)	3 (34)	3(34)	3 (34)	
		240V ac HP(FLA)	3 (17)	5 (28)	7.5 (40)	7,5 (40)	10 (50)	
		240V ac HP(FLA)	7.5 (22)	10 (28)	10 (28)	10 (28)	10 (28)	
	3-phase - 3-pole	480V ac HP(FLA)	10 (14)	15 (21)	20 (27)	25 (34)	25 (34)	
		600V ac HP(FLA)	15 (17)	20 (22)	25 (27)	30 (32)	30 (32)	

* Values certified by IMQ

Regolus

Switch-disconnectors

General characteristics



TECHNO-CONTROL EQUIPMENT

Comply with			IEC947-3, EN60947-3, UL508				
			SE16 - SE32		SE63 - SE80 - SE100		
Protection class	controls	EN60529	IP65		IP65		
	terminals		IP20		IP20		
Material group		EN60947-1	II		II		
Pollution grade		EN60947-1	3		3		
Flammability		UL94	VO: live parts				
Ambient temperature		°C	Operating: -25 +55				
		°C	Storage: -30 +70				
Climate protection		IEC68 part 2-3	Hot damp				
		IEC68 part 2-30	Unsettled hot damp				
Minimum tripping force (4-pole)			0.7 Nm (6.3 lb.in.)		1.8 Nm (16 lb.in.)		
Terminals:							
Dimensions		EN60947-1	A6		A8		
Terminal screw			M4		M5		
Torque		EN60947-1	0.8 Nm (7.2 lb.in.)		1.2 Nm (10.6 lb.in.)		
		UL508	7.5 lb.in. (0.85 Nm)		12 lb.in. (1.4 Nm)		
Capacity:							
Flexible conductors	No. 1 min/max	mm ²	1.5-10		6-25		
		AWG	16-3		10-2		
Solid conductors	No. 1 min/max	mm ²	1.5-16		10-35		
		AWG	16-8		10-2		
Contacts			Double gap contacts with positive opening action				
Opening angles			90°		90°		
Mechanical life	120 operations per hour	mil./cycles	0.1		0.1		
CE mark – Europa			■	■	■	■	■
CUL Listed – USA and Canada			●	●	●	●	●
Istituto Marchio Qualità (IMQ) – Italy			●	●	●	●	-
CCC Cina			●	●	●	●	-
GOST-R Russia			●	●	●	●	-

■ Meets or exceed the minimum requirements ● Certified

Regolus

Switch-disconnectors

Assembly

ASSEMBLY EXPLODED VIEW

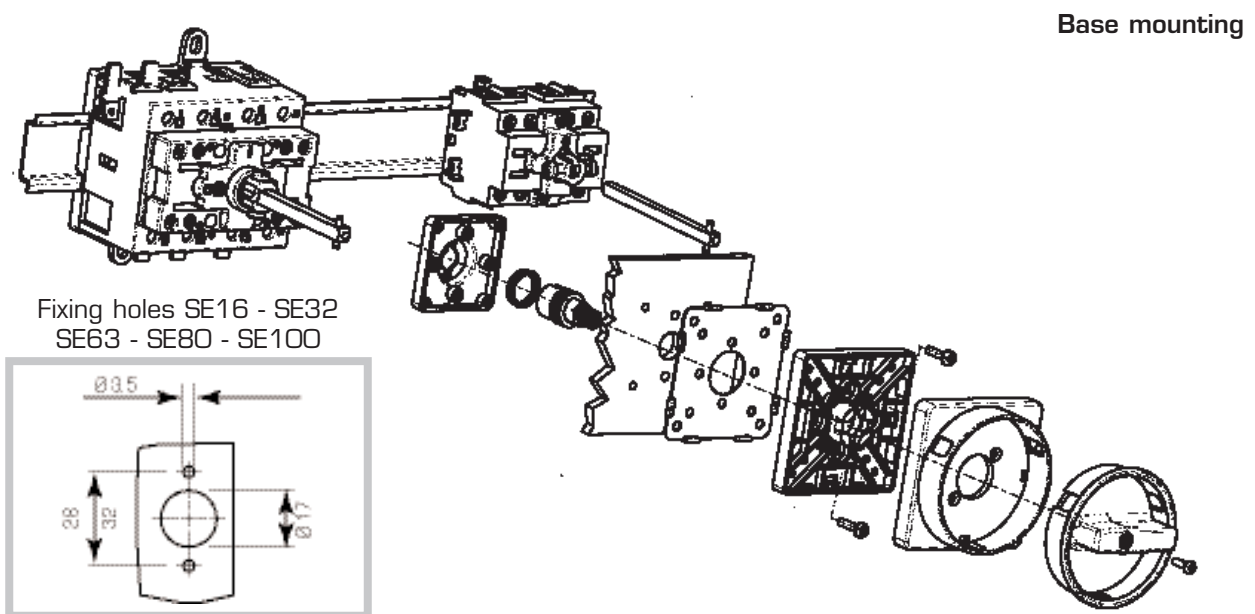
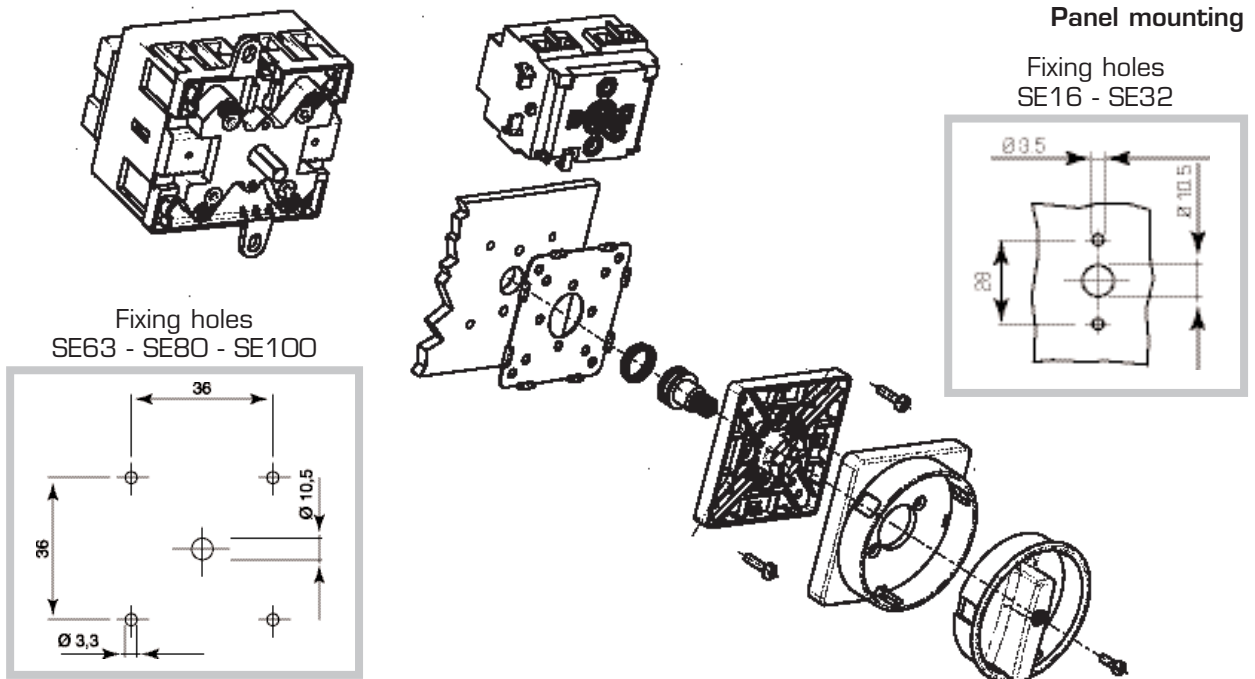

Regolus

Dimensions

Fixing holes



TECHNO-CONTROL EQUIPMENT

PANEL MOUNTING

SE16-SE32 R

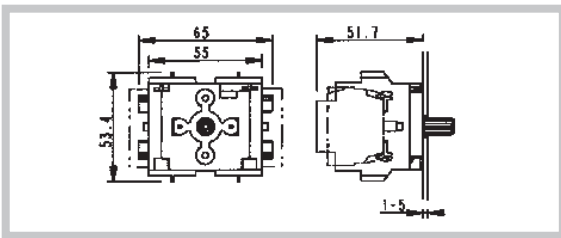

SE63-SE80-SE100 R

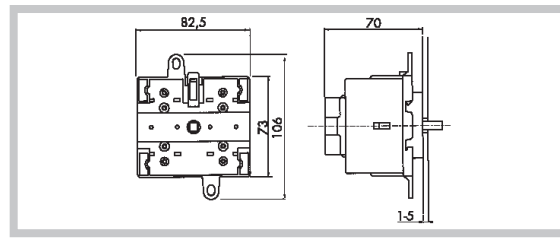

BASE MOUNTING

SE16-SE32 B

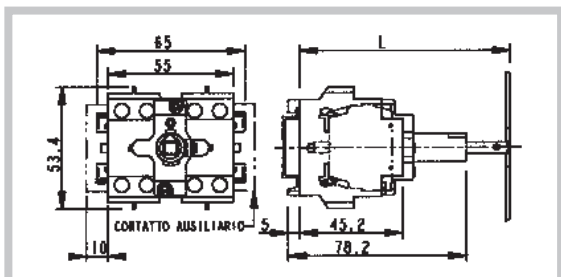

DEPTH

	WITH SHAFT AS STANDARD	WITH 20401089 EXTENSION
L min	80	80
L max	120	220

SE63-SE80-SE100 B

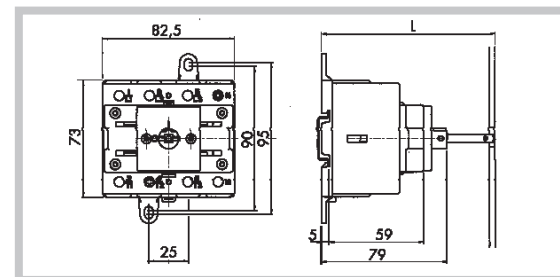

DEPTH

	WITH SHAFT AS STANDARD	WITH 20900010 EXTENSION
L min	98	98
L max	128	228

ENCLOSED INSTALLATION

SE16-SE32

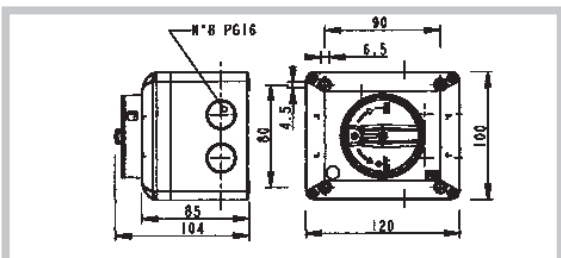

SE63-SE80-SE100

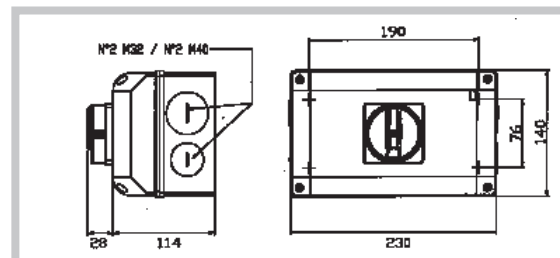

Pegasus

Control auxiliaries

Table of contents



TECHNO-CONTROL EQUIPMENT



Panel mounting on \varnothing 22.5 mm holes, IP65 protection rating, available with "black" or "chrome" finish, EN418 emergency mushrooms, terminals with screws, spring loaded or for printed circuit boards. Push button stations up to 3 gang or enclosures up to 6 gang. Version for pneumatic systems available.

TABLE OF CONTENTS

■ Assembly	pag. 46	■ Contact blocks – Power supplies	pag. 58
■ \varnothing 22 push buttons with colour cap	pag. 47	■ Spring loaded terminals	
■ EN 418 emergency push buttons	pag. 48	■ Contact blocks – Power supplies	pag. 59
■ Rotary switches	pag. 50	■ Screw terminals	
■ \varnothing 22 push buttons with lens cap	pag. 51	■ IP65 push button stations (single function)	pag. 60
■ LED pilot lights – Multi-function push buttons	pag. 52	■ EN418 emergency push button stations	pag. 61
■ Joystick operators	pag. 53	■ IP65 push button stations (multi-function)	pag. 62
■ Chrome line \varnothing 22 push buttons with colour cap	pag. 54	■ Push button station enclosures	pag. 63
■ Chrome line rotary switches	pag. 55	■ Pneumatic valve adapters	pag. 64
■ Chrome line \varnothing 22 push buttons with lens cap	pag. 56	■ Accessories	pag. 65
■ Chrome line multi-function push buttons	pag. 57	■ Accessories – Push buttons with symbols	pag. 66
		■ Electrical characteristics	pag. 68
		■ General characteristics	pag. 69

Pegasus

Control auxiliaries

Assembly instructions

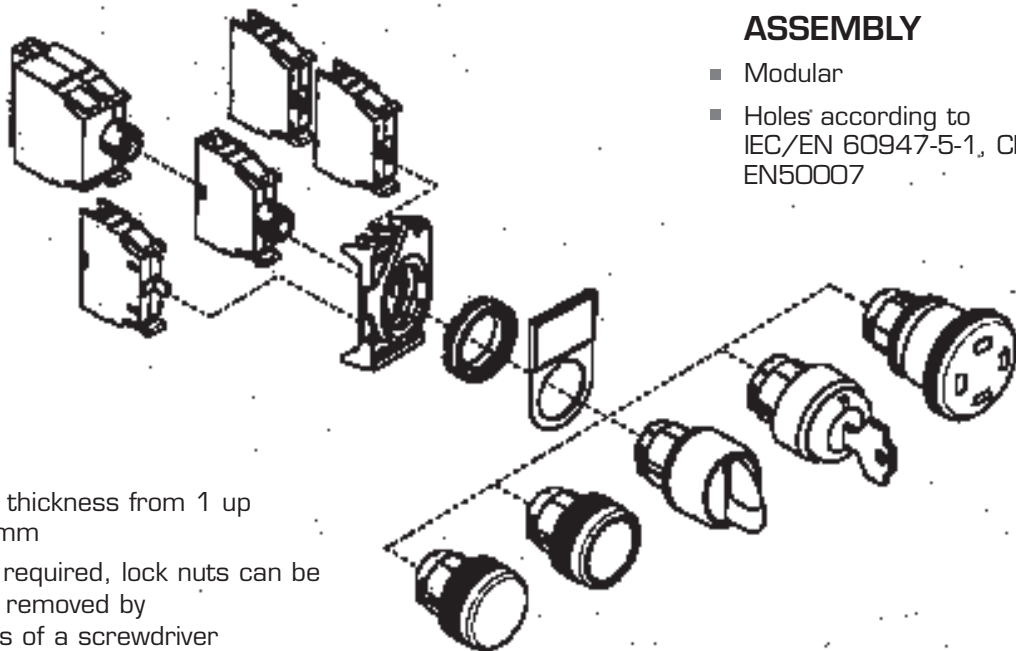

ASSEMBLY

- Modular
- Holes according to IEC/EN 60947-5-1, CENELEC EN50007

- Panel thickness from 1 up to 6 mm
- If not required, lock nuts can be easily removed by means of a screwdriver

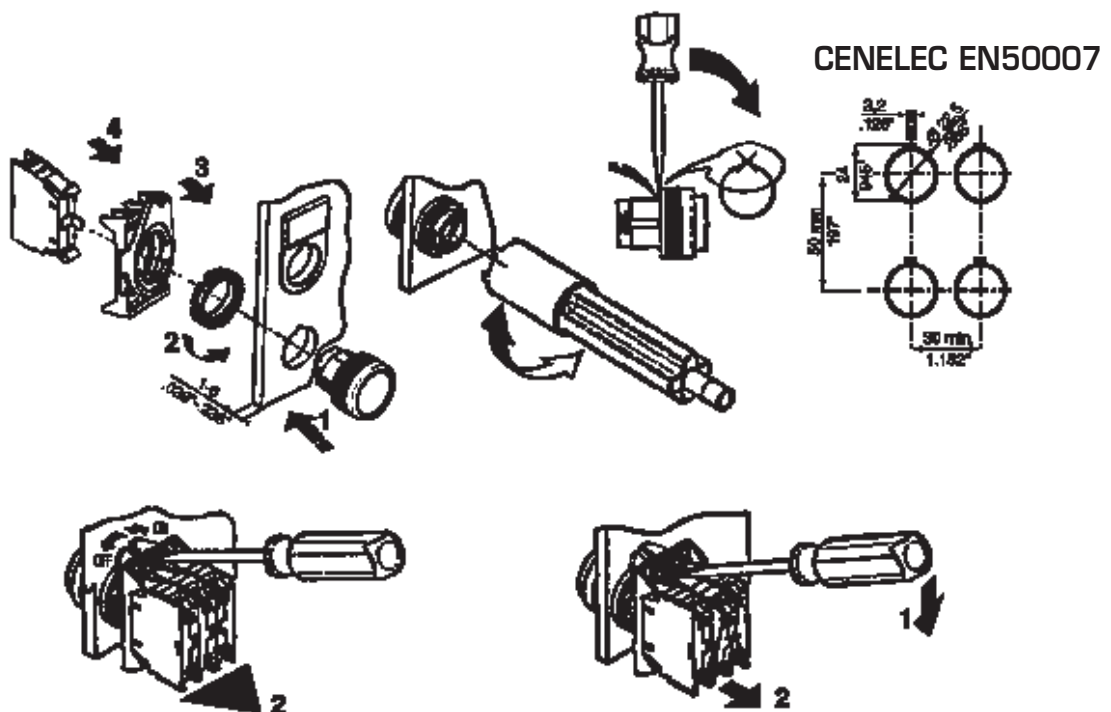









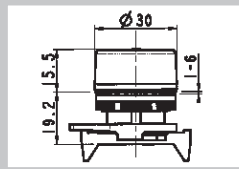

Pegasus

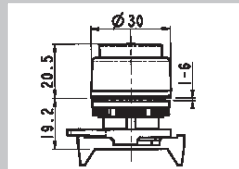
ø 22 Push buttons

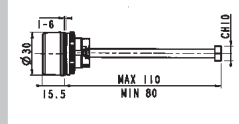
With colour cap

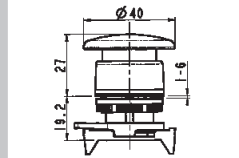
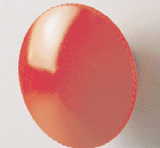
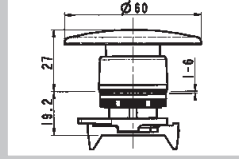

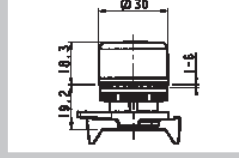

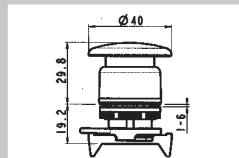







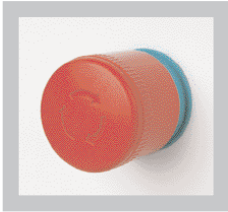

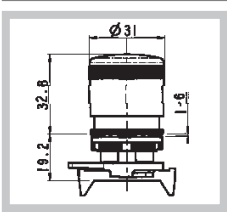
TECHNO-CONTROL EQUIPMENT

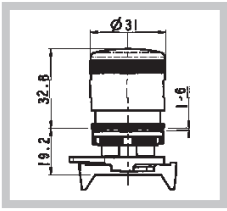
STANDARD	DESCRIPTION	COLOUR	REF. NO.	WEIGHT g	MIN. PACK QTY.	DIMENSIONS			
	Flush push button	■	PPRN1	30	10				
		■	PPRN2	30	10				
		■	PPRN3	30	10				
		■	PPRN4	30	10				
		■	PPRN5	30	10				
		■	PPRN8	30	10				
			Extended push button	■	PPSN1		31	10	
				■	PPSN2		31	10	
■	PPSN3			31	10				
■	PPSN4			31	10				
■	PPSN5			31	10				
■	PPSN8			31	10				
	Flush reset push button			■	PPRN4R	43	10		
	Mushroom operator ø 40			■	PPFN1M4N	35	10		
		■	PPFN2M4N	35	10				
		■	PPFN3M4N	35	10				
	Mushroom operator ø 60	■	PPFN1M6N	40	10				
LATCHED									
	Flush push button	■	PPP1N1	32	10				
		■	PPP1N2	32	10				
		■	PPP1N3	32	10				
		■	PPP1N4	32	10				
		■	PPP1N5	32	10				
		■	PPP1N8	32	10				
			Mushroom operator ø 40	■	PPFN1S4N		35	10	
				■	PPFN2S4N		35	10	
■	PPFN3S4N			35	10				

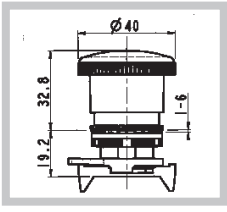
Pegasus

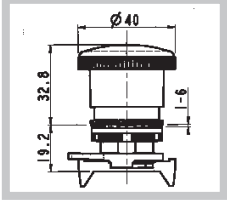
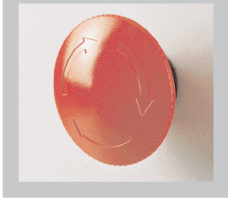
Emergency push buttons

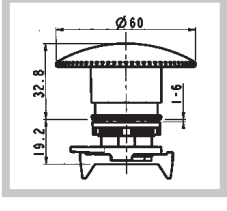
EN418

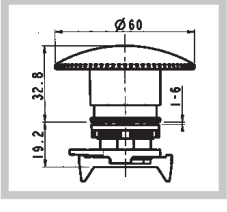







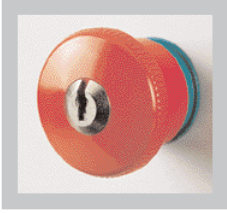

	DESCRIPTION	COLOUR	REF. NO.	WEIGHT g	MIN. PACK QTY.	DIMENSIONS
	Mushroom operator Ø 30 twist to release		PPFN1R3N	42	10	
	Mushroom operator with vision Ø 30 twist to release		PPFN1R3S	44	10	
	Mushroom operator Ø 40 twist to release		PPFN1R4N	44	10	
	Mushroom operator with vision Ø 40 twist to release		PPFN1R4S	46	10	
	Mushroom operator Ø 60 twist to release		PPFN1R6N	50	10	
	Mushroom operator with vision Ø 60 twist to release		PPFN1R6S	52	10	

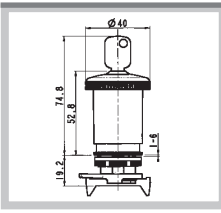
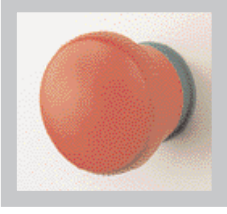
Pegasus

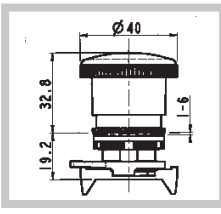
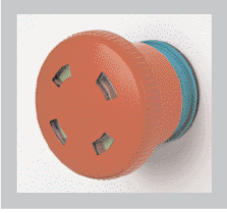
Emergency push buttons EN418

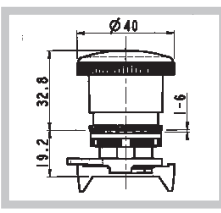
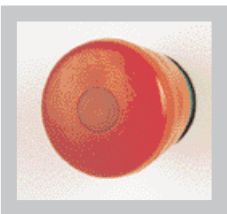

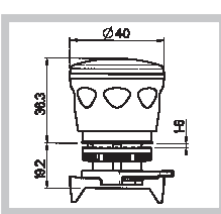
TECHNO-CONTROL EQUIPMENT

	DESCRIPTION	COLOUR	REF. NO.	WEIGHT g	MIN. PACK QTY.	DIMENSIONS
	Mushroom operator ø 40 with key release		PPFN1C4N	76	10	
	Mushroom operator ø 40 push-pull		PPFN1P4N	44	10	
	Mushroom operator ø 40 push-pull with vision		PPFN1P4S	46	10	
	Mushroom operator ø 40 push-pull with colour cap		PPFN1P4C	45	10	
	Mushroom operator ø 40 push-pull with lens cap		PPFL1P4N	45	10	

TECHNICAL NOTES

- All operators comply with the relevant European standard
- EN418 Machine safety
Emergency stop operators, functional characteristics – Design guidelines
- IEC/EN60947-5-1
- Comply with the standard IEC/EN60204-1: Machine safety – Machine electrical circuits – General guidelines
- The push buttons are designed with a load charge mechanism to ensure a reliable operation and stoppage, or blockage, in the activated position. The combination with positive switching NC  contacts and the presence of the “status” indicator on some models, guarantee a high degree of reliability and effectiveness.

Pegasus

Rotary switches

Standard and with lens

WITH SHORT OPERATOR



WITH LONG OPERATOR



WITH KEY



POSITIONS	WITH SHORT OPERATOR		WITH LONG OPERATOR		KEY REMOVAL			REF.NO.
	COL.INDEX	REF.NO.	COL.INDEX	REF.NO.	Sn	O	Dx	
	■	PSMB1DO	■	PSLB1DO		*		PSCG8DOC
	■	PSMB2DO	■	PSLB2DO				
	■	PSMB3DO	■	PSLB3DO			*	PSCG8DOE
	■	PSMB4DO	■	PSLB4DO				
	■	PSMB5DO	■	PSLB5DO		*	*	PSCG8DON
	■	PSMB8DO	■	PSLB8DO				
	■	PSMB1D2	■	PSLB1D2		*		PSCG8D2C
	■	PSMB2D2	■	PSLB2D2				
	■	PSMB3D2	■	PSLB3D2				
	■	PSMB4D2	■	PSLB4D2				
	■	PSMB5D2	■	PSLB5D2				
	■	PSMB8D2	■	PSLB8D2				
	■	PSMB1T0	■	PSLB1T0	*	*		PSG8TOC
	■	PSMB2T0	■	PSLB2T0				PSG8TOA
	■	PSMB3T0	■	PSLB3T0			*	PSG8TOE
	■	PSMB4T0	■	PSLB4T0	*	*	*	PSG8TOG
	■	PSMB5T0	■	PSLB5T0	*	*	*	PSG8TOH
	■	PSMB8T0	■	PSLB8T0	*	*	*	PSG8TOK
	■	PSMB1T3	■	PSLB1T3		*		PSCG8T3C
	■	PSMB2T3	■	PSLB2T3				
	■	PSMB3T3	■	PSLB3T3				
	■	PSMB4T3	■	PSLB4T3				
	■	PSMB5T3	■	PSLB5T3				
	■	PSMB8T3	■	PSLB8T3				
	■	PSMB1T2	■	PSLB1T2		*		PSCG8T2C
	■	PSMB2T2	■	PSLB2T2				
	■	PSMB3T2	■	PSLB3T2	*			PSCG8T2A
	■	PSMB4T2	■	PSLB4T2				
	■	PSMB5T2	■	PSLB5T2	*	*		PSCG8T2H
	■	PSMB8T2	■	PSLB8T2				
	■	PSMB1T1	■	PSLB1T1		*		PSCG8T1C
	■	PSMB2T1	■	PSLB2T1				
	■	PSMB3T1	■	PSLB3T1			*	PSCG8T1E
	■	PSMB4T1	■	PSLB4T1				
	■	PSMB5T1	■	PSLB5T1		*	*	PSCG8T1N
	■	PSMB8T1	■	PSLB8T1				

1 For standard rotary switches suitable to operate a central contact, replace the letter "B" with the letter "C": PSMB...C...

2 For rotary switches with Left-Right operating angles replace the letters "DO" with "SD": PSMB1SD or PSCG8SDC

* Key removal position

Pegasus

Ø 22 push buttons

With lens cap



TECHNO-CONTROL EQUIPMENT

STANDARD

DESCRIPTION	COL. INDEX	REF. NO.	WEIGHT g	MIN. PACK QTY.	DIMENSIONS
Flush push button		PPRL1	30	10	
		PPRL2	30	10	
		PPRL3	30	10	
		PPRL4	30	10	
		PPRL5	30	10	

Extended push button		PPSL1	31	10	
		PPSL2	31	10	
		PPSL3	31	10	
		PPSL4	31	10	
		PPSL5	31	10	

Mushroom operator Ø 40		PPFL1M4N	35	10	
------------------------	--	----------	----	----	--

LATCHED

Flush push button		PPPL1	32	10	
		PPPL2	32	10	
		PPPL3	32	10	
		PPPL4	32	10	
		PPPL5	32	10	

Mushroom operator Ø 40		PPFL1S4N	35	10	
		PPFL2S4N	35	10	
		PPFL3S4N	35	10	

INDICATOR LIGHT

Flat cap		PLSL1	30	10	
		PLSL2	30	10	
		PLSL3	30	10	
		PLSL4	30	10	
		PLSL5	30	10	

PILOT LIGHT

BA9s E10		PLML1	15	10	
		PLML2	15	10	
		PLML3	15	10	
		PLML4	15	10	
		PLML5	15	10	

Pegasus







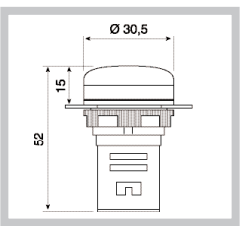

LED pilot lights

Multi-function push buttons

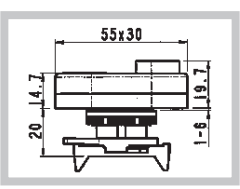

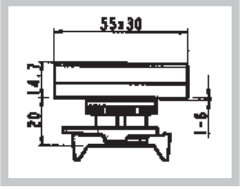

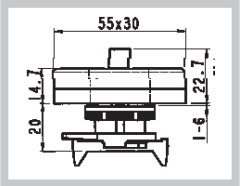

LED PILOT LIGHTS

DESCRIPTION	POWER SUPPLY	REF. NO.	WEIGHT g	MIN. PACK QTY.	DIMENSIONS
 Single light indicator	AC110V	PLML 2 L110*	15	10	
	AC220V	PLML 2 L220*	15	10	
	AC380V ¹	PLML 2 L380	15	10	
	AC/DC 6V ¹	PLML 2 L6	15	10	
	AC/DC 12V ¹	PLML 2 L12	15	10	
	AC/DC 24V	PLML 2 L24	15	10	
	AC/DC 48V	PLML 2 L48	15	10	

MULTI-FUNCTION PUSH BUTTONS

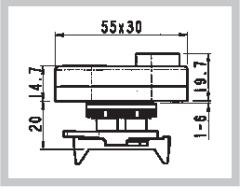
DESCRIPTION	COL. - SYMBOL	REF. NO.	WEIGHT g	MIN. PACK QTY.	DIMENSIONS
 Dual push button		PPDN	38	10	
 Flush dual push button		PPDNR	38	10	
		PPDNR.3	38	10	
 Triple push button		PPMN	40	10	

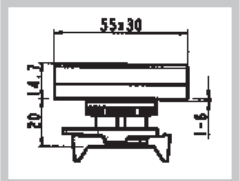
MULTI-FUNCTION PUSHBUTTONS - WITH LENS

 Dual push button		PPDL	30	10	
 Flush dual push button		PPDLR	30	10	
		PPDLR.3	30	10	

¹ Made to order

² Insert lens colour code: 1 - red, 2 - green, 3 - yellow, 4 - blue, 5 - white

Multi-function push buttons - Special symbols and text for horizontal assembly/identification are available on request

* For AC/DC applications add the letter "S": PLML.L110S

Pegasus

Joystick operators

With colour caps



TECHNO-CONTROL EQUIPMENT

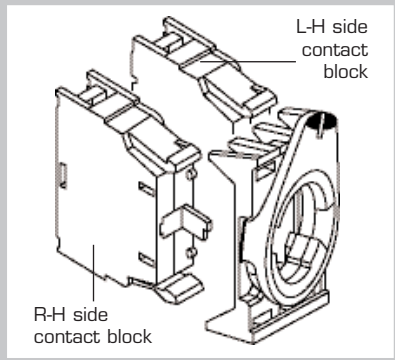

JOYSTICK OPERATORS

CONTACT BLOCKS		2 POSITIONS			4 POSITIONS				
		1	0	2	3	1	0	2	4
Left-hand side contact block	NO	0	0	X	X	0	0	0	0
	NC	X	0	0	0	0	0	0	X
Right-hand side contact block	NO	X	0	0	0	X	0	0	0
	NC	0	0	X	0	0	0	X	0

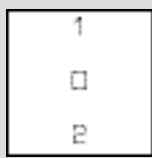

X Contact close

0 Contact open

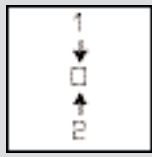
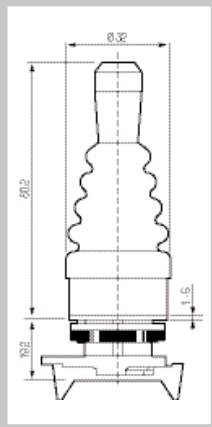
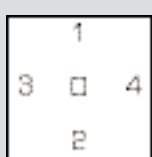
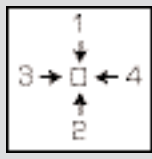











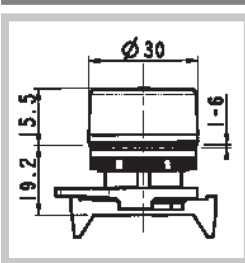



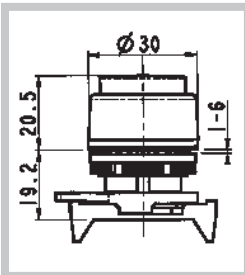

	POSITIONS	REF.NO.	REF.NO.	WEIGHT g	MIN.PACK	DIMENSIONS
		PMJN8TO	-	54	5	
		PMJN8T3	-	54	5	
		-	PMJN8Q0	54	5	
		-	PMJN8Q4	54	5	

Pegasus







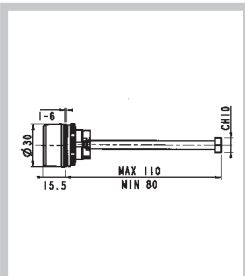

Push buttons \varnothing 22

With colour caps – Chrome line

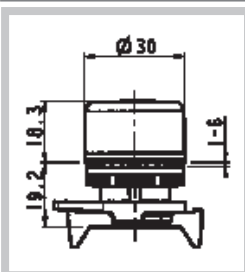
STANDARD

	DESCRIPTION	COLOUR	REF. NO.	WEIGHT g	MIN. PACK QTY.	DIMENSIONS
	Flush push button		PPRN1CL	30	10	
			PPRN2CL	30	10	
			PPRN3CL	30	10	
			PPRN4CL	30	10	
			PPRN5CL	30	10	
			PPRN8CL	30	10	
	Extended push button		PPSN1CL	31	10	
			PPSN2CL	31	10	
			PPSN3CL	31	10	
			PPSN4CL	31	10	
			PPSN5CL	31	10	
			PPSN8CL	31	10	
	Flush reset push button		PPRN4RCL	43	10	

LATCHED

	DESCRIPTION	COLOUR	REF. NO.	WEIGHT g	MIN. PACK QTY.	DIMENSIONS
	Flush push button		PPPN1CL	31	10	
			PPPN2CL	31	10	
			PPPN3CL	31	10	
			PPPN4CL	31	10	
			PPPN5CL	31	10	
			PPPN8CL	31	10	

Pegasus

Rotary switches

Standard and with lens – Chrome line



TECHNO-CONTROL EQUIPMENT

WITH SHORT OPERATOR



WITH LONG OPERATOR



WITH KEY

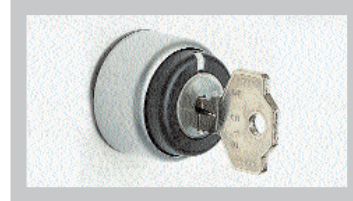

POSITIONS	COL. INDEX	REF. NO.	COL. INDEX	REF. NO.	KEY REMOVAL			REF. NO.
					Sn	O	Dx	
	■	PSMB1DOCL	■	PSLB1DOCL		*		PSCG8DOCCCL
	■	PSMB2DOCL	■	PSLB2DOCL				PSCG8DOECL
	■	PSMB3DOCL	■	PSLB3DOCL			*	
	■	PSMB4DOCL	■	PSLB4DOCL			*	PSCG8DONCL
	■	PSMB5DOCL	■	PSLB5DOCL		*	*	
	■	PSMB8DOCL	■	PSLB8DOCL				
	■	PSMB1D2CL	■	PSLB1D2CL				PSCG8D2CCL
	■	PSMB2D2CL	■	PSLB2D2CL		*		
	■	PSMB3D2CL	■	PSLB3D2CL				
	■	PSMB4D2CL	■	PSLB4D2CL				
	■	PSMB5D2CL	■	PSLB5D2CL				
	■	PSMB8D2CL	■	PSLB8D2CL				
	■	PSMB1TOCL	■	PSLB1TOCL		*	*	PSG8TOCCCL
	■	PSMB2TOCL	■	PSLB2TOCL	*		*	PSG8TOACCL
	■	PSMB3TOCL	■	PSLB3TOCL	*	*	*	PSG8TOECL
	■	PSMB4TOCL	■	PSLB4TOCL	*	*	*	PSG8TOGCL
	■	PSMB5TOCL	■	PSLB5TOCL	*		*	PSG8TOHCL
	■	PSMB8TOCL	■	PSLB8TOCL		*	*	PSG8TONCL
	■	PSMB1T3CL	■	PSLB1T3CL				PSCG8T3CCL
	■	PSMB2T3CL	■	PSLB2T3CL		*		
	■	PSMB3T3CL	■	PSLB3T3CL				
	■	PSMB4T3CL	■	PSLB4T3CL				
	■	PSMB5T3CL	■	PSLB5T3CL				
	■	PSMB8T3CL	■	PSLB8T3CL				
	■	PSMB1T2CL	■	PSLB1T2CL		*		PSCG8T2CCL
	■	PSMB2T2CL	■	PSLB2T2CL				PSCG8T2ACL
	■	PSMB3T2CL	■	PSLB3T2CL	*			
	■	PSMB4T2CL	■	PSLB4T2CL				PSCG8T2HCL
	■	PSMB5T2CL	■	PSLB5T2CL	*	*		
	■	PSMB8T2CL	■	PSLB8T2CL				
	■	PSMB1T1CL	■	PSLB1T1CL		*		PSCG8T1CCL
	■	PSMB2T1CL	■	PSLB2T1CL				PSCG8T1ECL
	■	PSMB3T1CL	■	PSLB3T1CL			*	
	■	PSMB4T1CL	■	PSLB4T1CL			*	PSCG8T1NCL
	■	PSMB5T1CL	■	PSLB5T1CL		*	*	
	■	PSMB8T1CL	■	PSLB8T1CL				

1 For standard rotary switches suitable to operate a central contact, replace the letter "B" with the letter "C": PSMB...C...

2 For rotary switches with Left-Right operating angles replace the letters "DO" with "SD": PSMB1SD or PSCG8SDC







* Key removal position



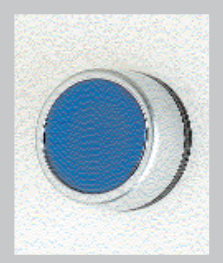

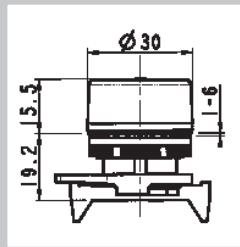

Pegasus

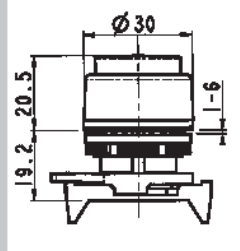

Ø 22 push buttons

With lens cap – Chrome line





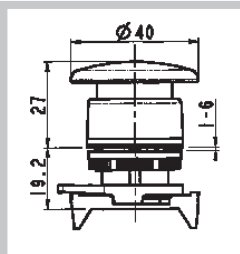

STANDARD

DESCRIPTION	COLOUR	REF. NO.	WEIGHT g	MIN. PACK QTY.	DIMENSIONS
 <p>Flush push button</p>		PPRL1CL	30	10	
		PPRL2CL	30	10	
		PPRL3CL	30	10	
		PPRL4CL	30	10	
		PPRL5CL	30	10	

 <p>Extended push button</p>		PPSL1CL	31	10	
		PPSL2CL	31	10	
		PPSL3CL	31	10	
		PPSL4CL	31	10	
		PPSL5CL	31	10	

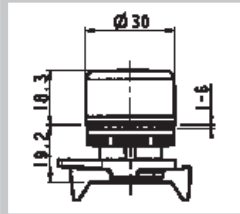
 <p>Mushroom operator Ø 40</p>		PPFL1M4NCL	43	10	
---	---	------------	----	----	---

LATCHED

DESCRIPTION	COLOUR	REF. NO.	WEIGHT g	MIN. PACK QTY.	DIMENSIONS
 <p>Flush push button</p>		PPPL1CL	31	10	
		PPPL2CL	31	10	
		PPPL3CL	31	10	
		PPPL4CL	31	10	
		PPPL5CL	31	10	

Pegasus







Multi-function push buttons

Chrome line



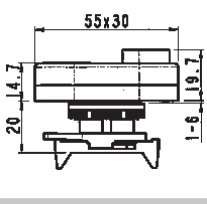

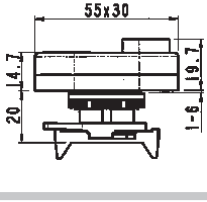
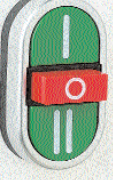

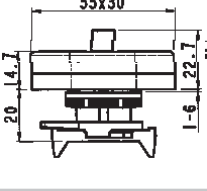
TECHNO-CONTROL EQUIPMENT

MULTI-FUNCTION PUSH BUTTONS

	DESCRIPTION	COL. - SYMBOL	REF. NO.	WEIGHT g	MIN. PACK QTY.	DIMENSIONS
	Dual push button		PPDNCL	38	10	
	Flush dual push button		PPDNRCL	38	10	
	Triple push button		PPMNCL	40	10	

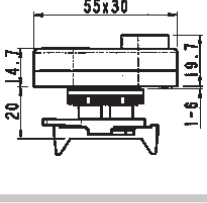
MULTI-FUNCTION PUSH BUTTONS - WITH LENS

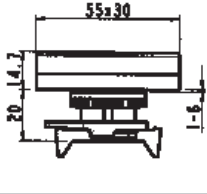
	Dual push button		PPDLCL	38	10	
	Flush dual push button		PPDLRCL	38	10	

1 Made to order





Multi-function push buttons – Special symbols and text for horizontal assembly/identification are available on request

Pegasus

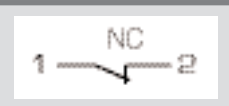

Contact blocks – Power supplies

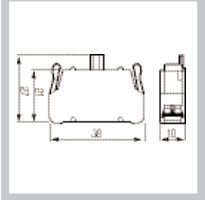
Spring loaded and welding terminals

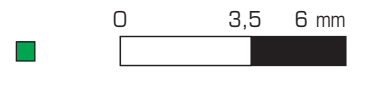

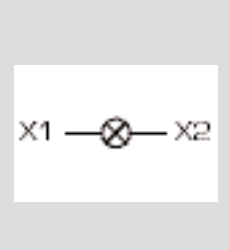
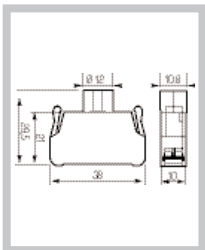

SPRING LOADED TERMINALS

	DESIGNATION	CONTACT BLOCKS FUNCTIONS	REF. NO.	DIMENSIONS
		 0 1,5 6 mm	PCW01	
		 0 3,5 6 mm	PCW10	

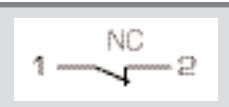

LAMPHOLDER

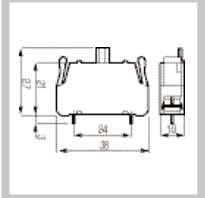
	DESIGNATION	DIRECT POWER SUPPLY		WITH BUILT-IN LED		DIMENSIONS
		POWER SUPPLY	REF. NO.	POWER SUPPLY	REF. NO.	
		BA9s	PCWAD	AC/DC 12V	PCW ² L12	
		250V max		AC/DC 24V	PCW ² L24	
		Lamp ¹		AC/DC 48V	PCW ² L48	
		2,4W max		AC/DC 110V	PCW ² L110	
				AC 220V	PCW ² L220	

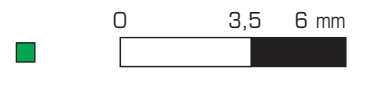
WELDING TERMINALS - FOR PRINTED CIRCUIT BOARDS

	DESIGNATION	CONTACT BLOCKS FUNCTIONS	REF. NO.	DIMENSIONS
		 0 1,5 6 mm	PSC01	
		 0 3,5 6 mm	PSC10	

LAMPHOLDER

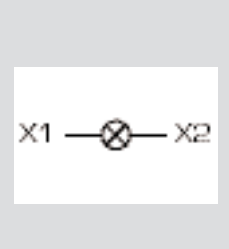
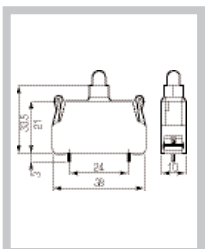
	DESIGNATION	DIRECT POWER SUPPLY		WITH BUILT-IN LED		DIMENSIONS
		POWER SUPPLY	REF. NO.	POWER SUPPLY	REF. NO.	
		BA9s	PSCAD	AC/DC 12V	PSC ² L12	
		250V max		AC/DC 24V	PSC ² L24	
		Lamp ¹		AC/DC 48V	PSC ² L48	
		2,4W max		AC/DC 110V	PSC ² L110	
				AC 220V	PSC ² L220	

¹ Lamp supplied separately

² Insert LED colour reference no.: 1-red, 2-green, 5-white

Pegasus

Contact blocks – Power supplies

Screw terminals



TECHNO-CONTROL EQUIPMENT

CONTACT BLOCKS

	DESIGNATION	FUNCTIONS	REF. NO.	DIMENSIONS
	1 — 2 NC	0 1,5 6 mm	PL004001	
	3 — 4 NO	0 3,5 6 mm	PL004002	

LAMPHOLDER

	DESIGNATION	DIRECT POWER SUPPLY POWER SUPPLY REF. NO.	WITH BUILT-IN LED POWER SUPPLY REF. NO.	DIMENSIONS
	X1 — ⊗ — X2	BA9s	AC/DC 12V PLO04 2 L12	
		250V max Lamp 1	AC/DC 24V PLO04 2 L24	
		PL004007	AC/DC 48V PLO04 2 L48	
			AC/DC 110V PLO04 2 L110	
			AC 220V PLO04 2 L220	

POWER SUPPLY WITH DIODE AND RESISTORS

	DESIGNATION	SUPPLY	LAMP 1	REF. NO.	DIMENSIONS
	X1 — ⊗ — X2	110/130V	48/60V -2W max	PL004RD1	
	X1 — ⊗ — X2	220/240V	110/130V -2W max	PL004RD2	

POWER SUPPLY WITH TRANSFORMER

	DESIGNATION	SUPPLY	LAMP 1	REF. NO.	DIMENSIONS
	X1 — ⊗ — X2	110/130V	24V-1,5 max	PL004TR1	
		220/240V	24V-1,5 max	PL004TR2	
		380/440V	24V-1,5 max	PL004TR3	

POWER SUPPLY WITH FLASHING LIGHT

	DESIGNATION	SUPPLY	LAMP 1	REF. NO.	DIMENSIONS
	X1 — ⊗ — X2	24V	24V-2,6 max	PL004LA1	
		110/130V	110/130V-2,6 max	PL004LA2	













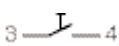
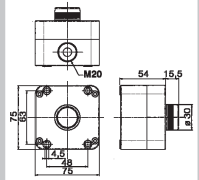

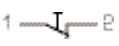



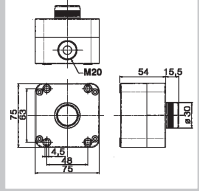



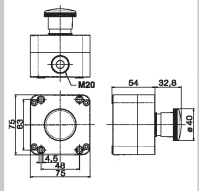

1 Lamp supply separately

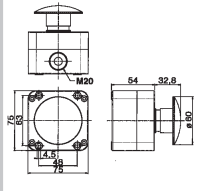
2 Insert LED colour reference no.: 1-red, 2-green, 5-white

Pegasus

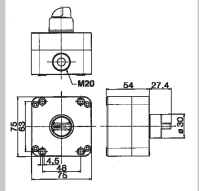
Push button stations

IP65 □ Screw terminal contact blocks

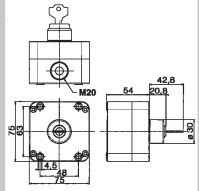







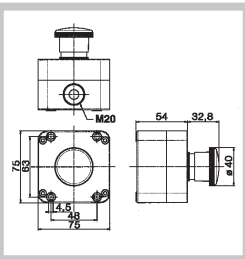

	DESCRIPTION	COL.	DESIGNATION	REF.NO.	WEIGHT g	MIN. PACK QTY.	DIMENSIONS
	Flush push button			PQ01RN2	176	1	
				PQ01RN1	176	1	
	Latched flush push button			PQ01PN2	176	1	
	Emergency stop ø 40			PQ01M4N	192	1	
	Emergency stop ø 60			PQ01M6N	198	1	
	Short operator latched rotary switch O-1			PQ01SMN8DO	174	1	
	90° angle latched key switch O-1 Key removable in O position			PQ01SCN8DOC	200	1	

Pegasus

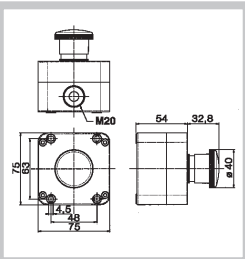
EN418 emergency push button stations IP65 □ Screw terminal contact blocks

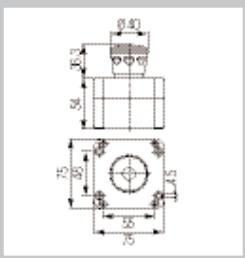

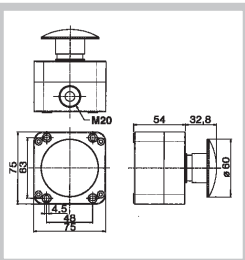
TECHNO-CONTROL EQUIPMENT

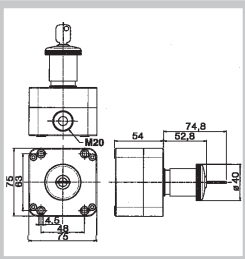









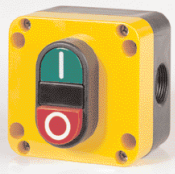

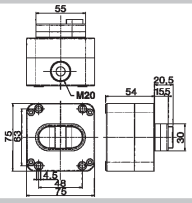

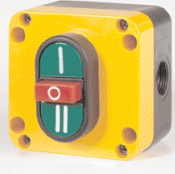
	DESCRIPTION	COL.	DESIGNATION	REF.NO	WEIGHT g	MIN. PACK QTY.	DIMENSIONS
	Emergency stop \varnothing 40 twist to release	■	1 	PQ01R4N	190	1	
	Emergency stop \varnothing 40 push-pull	■	1 	PQ01P4N	192	1	
	Emergency stop pushbutton \varnothing 40 push-pull with vision	■	1 	PQ01P4L ¹	190	1	
	Emergency stop \varnothing 60 push-pull	■	1 	PQ01P6N	198	1	
	Emergency stop \varnothing 40 with key release	■	1 	PQ01C4N	222	1	

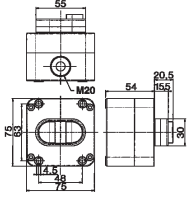
¹ Insert power supply reference: for AC/DC 12V, 24V, 48V, 110V = L12, L24, L48, L110; for AC 220V = L220

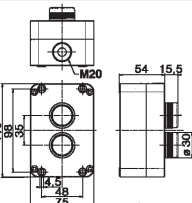
Pegasus

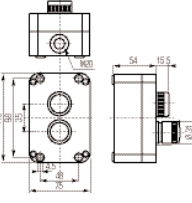
Push button stations

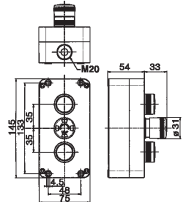
IP65 □ Screw terminal contact blocks

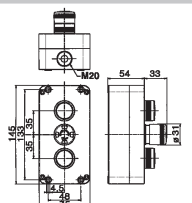
	DESCRIPTION	COL.	DESIGNATION	REF.NO.	WEIGHT g	MIN. PACK QTY.	DIMENSIONS
	Dual push button		3 — 4 1 — E	PQ01PDN	184	1	
	Dual push button with lens		3 — 4 X1 — X2 1 — 2	PQ01PDL			
	Triple push button		3 — 4 1 — E 3 — 4	PQ01PMN	186	1	
	With No. 2 push buttons		3 — 4 3 — 4	PQ02B	264	1	
	With No. 1 push button and No. 1 EN418 emergency stop		3 — 4 1 — E	PQ02A	264	1	
	With No. 1 push button, No. 1 EN418 emergency stop and pilot light		3 — 4 1 — E X1 — X2	PQ03A	350	1	
	With No. 2 push buttons and No. 1 EN418 emergency stop		3 — 4 1 — E 3 — 4	PQ03B	362	1	











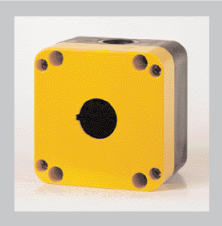

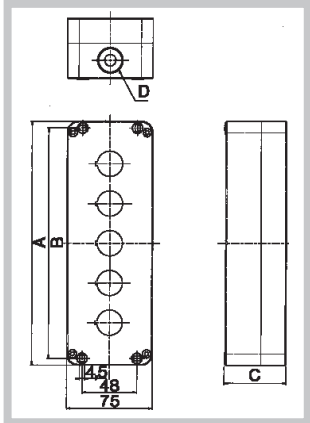

Pegasus

Push button station enclosures

IP65 □



TECHNO-CONTROL EQUIPMENT

DESCRIPTION	REF.NO.		WEIGHT g	MIN. PACK QTY.	DIMENSIONS
	FRONT COVER COLOUR				
 1 hole enclosure			134	1	
	PQ01K	PQ01KGN			
 2 holes enclosure			174	1	
	PQ02K	PQ02KGN			
 3 holes enclosure			214	1	
	PQ03K	PQ03KGN			
 4 holes enclosure			256	1	
	PQ04K	PQ04KGN			
 5 holes enclosure			296	1	
	PQ05K	PQ05KGN			

HOLE No.	A	B	C	D
1	75	63	54	1xM16 1xM20
2	110	98	54	2xM20
3	145	133	54	2xM20
4	180	168	57	2xM20
5	215	203	54	2xM20

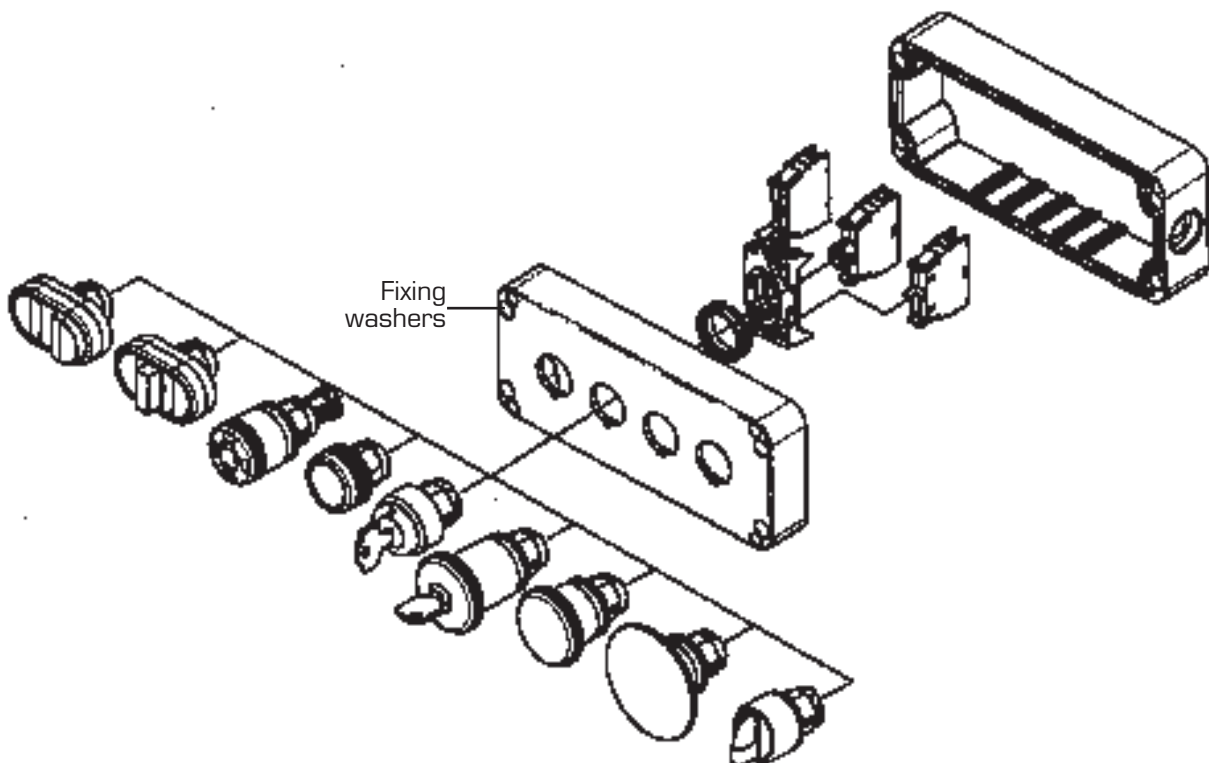

Pegasus

Control auxiliaries

Pneumatic valve adapters

Pegasus control auxiliaries are suitable for operating certain type of pneumatic or micro valves. Push buttons can be used for such applications using a set of adapters and supports.

The operators suitable for this use are the following:

- Standard push buttons with colour cap
- Mushroom operators
- Rotary and key operators

Adapters are supplied with an actuator to operate the pneumatic valve.

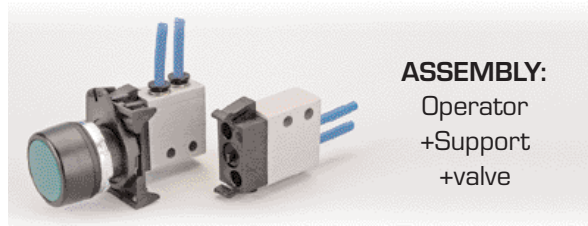

	DESCRIPTION	REFERENCE NO.	WEIGHT Gr.	MIN. PACK QTY.	DIMENSIONS
	Single adapter (for 1 valve) 1	AVP1	5	10	
	Twin adapter (for 2 valves) 1	AVP2	10	10	

3/2 NC - 3/2 NO MICROVALVE - 2÷10 BAR

BOTTOM ø 4 CABLE ENTRY	SIDE ø 4 CABLE ENTRY	TAPPED M5 BOTTOM CABLE ENTRY	
3/2 NC 3/2 NA	3/2 NC 3/2 NA	3/2 NC 3/2 NA	
REFERENCE NO.	REFERENCE NO.	REFERENCE NO.	REFERENCE NO.
V304MA	V314MA	V304MAL	V314MAL
V305MA	V315MA		

1 Complete with actuator to operate the valve or valves/To be installed in the centre of the operator

Pegasus

Control auxiliaries

Accessories



TECHNO-CONTROL EQUIPMENT

DIN-RAIL ADAPTER

For 53x45 mm distribution boards
3 DIN modules
RAL7035 grey colour
Weight 21 g.
Min. packing qty. 10 pcs.

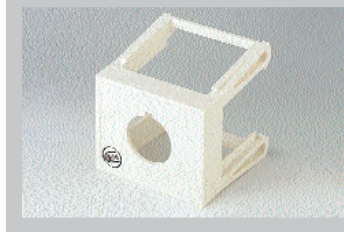

11708351

EMERGENCY STOP RING

Ø 60
Made of aluminium
Yellow background
black letters
Weight 3.5 g.
Min. packing qty. 10 pcs.



TEXT	REF.NO.
Blank	PTE
STOP EMERGENZA	PTE/I
EMERGENCY STOP	PTE/A
NOT AUS	PTE/D

COUPLING PLATE

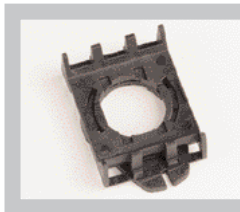

PPELN8

SEALING CAPS

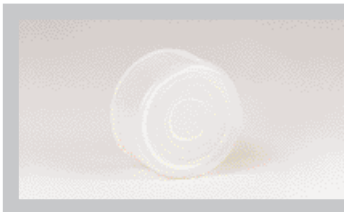

FOR PCR FLUSH PUSH BUTTONS

PCR

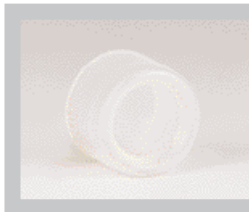

FOR PCS EXTENDED PUSH BUTTONS

PCS

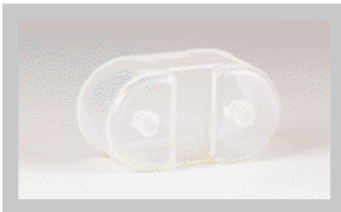

FOR MULTI-FUNCTION

TYPE	REF.NO.
PPDN-PPDL-PPDNCL-PPDLCL	PCD
PPMN-PPMNCL	PCM
PPDNR-PPDLR-PPDNRCL-PPDLRCL	PCN

CENTRAL CONTACT ACTUATOR

(selectors not included)



PAC

MOUNTING RING AND LAMP REMOVAL TOOL



PCF

Ø 22.5 HOLE PLUG



PTRN8

LEGEND PLATE



PPTN8

LABEL

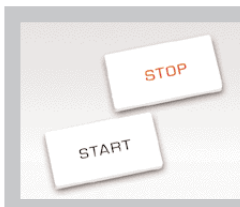

TEXT	REF.NO.
(Blank)	PTA00
MARCIA	PTA01
ARRESTO	PTA02

I O II	PTA03	EIN	PTA12
O I	PTA04	AUS	PTA13
I → O ← II	PTA17	STOP	PTA14
CHIUDE	PTA05	START	PTA15
APRE	PTA06	RESET	PTA16
EMERGENZA	PTA07	AUT O MAN	PTA18
MANUALE	PTA08	INS. - DISINS.	PTA26
AUTOMATICO	PTA09	HAND OFF AUTO	PTA27
AVANTI	PTA10	FORW OFF REV	PTA28
INDIETRO	PTA11	ON OFF	PTA29

FASTON AND PCB TERMINALS



FASTON	PCB
6,3x0,8	
11708341	11708235

Pegasus

Control auxiliaries

With engraved caps



Black

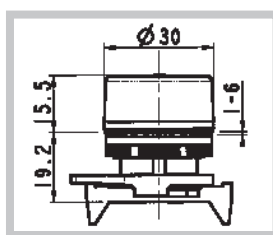

Chrome



SYMBOL	COLOUR AND TYPE	BLACK FRONT RING	CHROME FRONT RING	WEIGHT g.	MIN. PACK QTY.
	Green flush push button	PPRN2/I	PPRN2CL/I	30	10
	Red flush push button	PPRN1/O	PPRN1CL/O	30	10
	Green flush push button	PPRN2/II	PPRN2CL/II	30	10
	Green flush push button	PPRN2/START	PPRN2CL/ START	30	10
	Red flush push button	PPRN1/STOP	PPRN1CL/ STOP	30	10
	Green flush push button	PPRN2/ON	PPRN2CL/ ON	30	10

Pegasus

Control auxiliaries

With engraved caps



TECHNO-CONTROL EQUIPMENT



Black

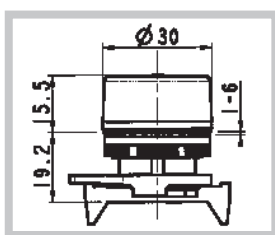

Chrome



SYMBOL	COLOUR AND TYPE	BLACK FRONT RING	CHROME FRONT RING	WEIGHT g.	MIN. PACK QTY.
	Red flush push button	PPRN1/OFF	PPRN1CL/OFF	30	10
	White flush push button	PPRN5/F	PPRN5CL/F	30	10
	Black flush push button	PPRN8/F	PPRN8CL/F	30	10
	Green flush push button	PPRN2/EIN	PPRN2CL/EIN	30	10
	Red flush push button	PPRN1/AUS	PPRN1CL/AUS	30	10

Pegasus

Technical data

Electrical characteristics

CONTACT BLOCKS

IEC/EN 60947-5-1 CHARACTERISTICS		PLO04001 - PLO04002								PCW01-PCW10 PSC01-PSC10									
Rated insulation voltage U_i	V	690 V*								690 V*									
Rated impulse withstand voltage U_{imp}	kV	4*								4*									
Operating frequency	Hz	50/60*								50/60*									
Rated thermal current I_{th}	A	16*								16*									
Rated thermal current enclosed I_{the}	A	10*								10*									
RATED OPERATING CURRENT I_e:																			
AC15: alternate current	V	24	60	110	230	400	440	500	690	24	60	110	240	400	440	500	690		
	A	16*	12	8	6	4,5	3,5	1*	1	16*	12*	5	5*	4	4	4*	2*		
DC13: direct current	V	24	48	60	110	220							24	48	60	110	250		
	A	2*	1.2	0.85	0.4	0.25*							2	2*	1*	0.4	0.4*		
Conditional short circuit withstand current	A	1000*								1000*									
Fuse rating gG	500 V	10A*								10A*									
Contact insulation resistance	mΩ	<25								<25									
Switching mechanism	Slow break double gap contacts																		
Contact duty	NC contact with positive opening \rightarrow																		
Minimum tripping force	mil./cycles	4N								4N									
Electrical life AC15		1A/1.5 - 2A/0.5 - 3A/0.25								1A/1.5 - 2A/0.5 - 3A/0.25									
UL 508 CHARACTERISTICS																			
General use		10A-600V ac 2.5A-125V dc								10A-600V ac 2.5-125V dc									
Heavy Duty (HD) category		A600-Q600								A600-Q600									

LED PILOT LAMP

IEC/EN 60947-5-1 CHARACTERISTICS		LED PLML.L				BA9s - E10 PLML.			
Rated insulation voltage U_i AC/DC	V	6 - 12 - 24 - 28				250			
Rated insulation voltage U_i AC	V	110 - 220 - 380				-			
Operating frequency	Hz	50/60				50/60			
Current I_e	mA	≤80 (6V - 12V) - ≤20 (24V...380V)				2 W max			
Brightness	cd/m ²	≤60				-			
Electrical life	h	≤30.000				-			

POWER SUPPLIES

IEC/EN 60947-5-1 CHARACTERISTICS		DIRECT PLO04007 PCWAD-PSCAD		LED PLO04.L. PCWL.-PSC..		RESISTOR PLO04RD.		TRANSFORMER PLO04TR.		FLASHING LIGHT PLO04LA.	
Rated insulation voltage U_i	V	690*		400		400		440		400	
Rated operating voltage U_e	V	400* 300 ¹		AC/DC 12-24		PRIMARY	SECONDARY	PRIMARY	SECONDARY	PRIMARY	SECONDARY
	V	-		AC/DC 48		110/130	48/60	110/130	24	24	24
	V	-		AC/DC 110		220/240	110/130	220/240	24	110/130	110/130
	V	-		AC 220		-	-	380/440	24	-	-
Max rated power	W	2.4* 2.5 ¹		-		2		1.5		2,6	
Power supply		AC/DC		-		-		AC		-	
Lamp fixing system		BA9s		-		BA9s		BA9s		BA9s	

¹ UL certified values

* IMQ certified values

Pegasus

Technical data

General characteristics



TECHNO-CONTROL EQUIPMENT

STANDARD CONFORMITY		
■ Approvals		UL, IMQ, CCC, GOST-R, R.I.NA
■ Protection class	EN60529	IEC947-5-1, EN60947-5-1, UL508
		IP65: push buttons, rotary switches
		IP65: mushroom operators
		IP65: pilot lights
		IP66: push buttons with sealing cap
		IP40: multi-function push buttons
		IP65: push button stations
		IP20: contact blocks with spring or screwless terminals
		IPO0: contact blocks with welding terminals
■ Material group	EN60947-1	II
■ Pollution grade	EN60947-1	3
■ Flammability	UL94	VO: live parts
■ Ambient temperature	°C	Operating: -25 +70
	°C	Storage: -30 +70
■ Climate protection	IEC68 part 2-3	Hot damp
	IEC68 part 2-30	Unsettled hot damp
Terminals referencing:		EN50013
■ Terminals:		
Dimensions		A2
Screw		M3,5
Torque		1.2Nm - EN60947-1 - 12 lb.in. UL508
■ Capacity:		
solid and flexible conductors	No. 1 min/max mm ²	1/2.5 screw terminals, 0.5-2.5 spring loaded terminals
	No. 2 min/max mm ²	1/2.5 screw terminals, 0.5-2.5 spring loaded terminals
	AWG	20-12 screw terminals
■ Mechanical life:		
Mushroom operators and standard		
Push buttons with colour cap	mil./cycles	3
Standard push buttons with lens cap		1
Latched push button with colour cap		1
Standard rotary switches		1
Rotary switches with lens, latched		
pushbutton with lens cap, joysticks		0.5
Emergency stop push buttons with release		0.3

Limit Switches

FA - FT - FT1R - Safety - FCT - Astra Series

Table of contents



TECHNO-CONTROL EQUIPMENT



Thermoplastic and die-cast aluminium limit switches



Limit switches with reset



Safety limit switches

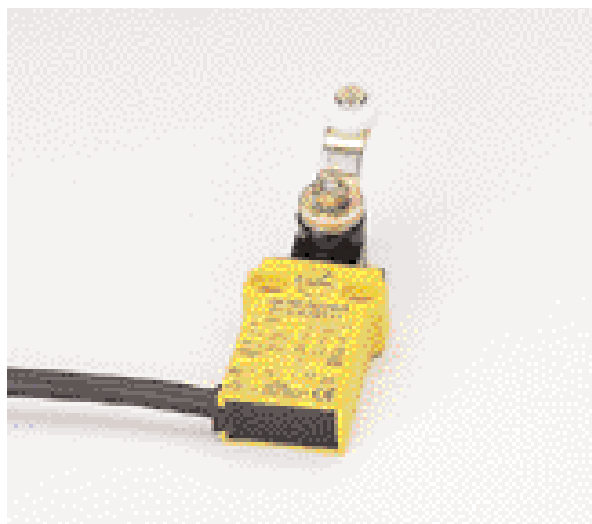

Pre-wired thermoplastic limit switches

TABLE OF CONTENTS

■ Introduction	pag. 72	■ Installation and use	pag. 91
■ FA series limit switches	pag. 74	■ Technical data	pag. 92
■ FT series limit switches	pag. 80	■ FCT series limit switches Pre-wired	pag. 93
■ Safety limit switches with reset	pag. 87	■ Astra universal limit switches	pag. 94
■ Safety limit switches	pag. 89		

Limit Switches

FA - FT - FT1R - Safety - FCT - Astra Series

Terminology

DOUBLE INSULATION

Materials of group II, according to IEC536, are made with double insulation. This consists of doubling the insulation capability by means

of an additional divider in order to eliminate any electrical shock risk and avoid the need for any additional protections.

POSITIVE OPENING OPERATION

A limit switch complies to this specification when all the normally closed contact elements of the switch can be changed, with certainty, to the open position (no flexible link between the moving contacts and the operator of the switch, to which an actuating force is applied). Positive opening does not apply to NO contacts. Control switches

with positive opening operation can be equipped with either slow-break or snap-action contacts. In order to use different contacts on the same switch, it is necessary to electrically separate them; otherwise only one contact can be used. Every positive opening control switch must be marked on the external housing with the symbol .

SNAP-ACTION CONTACTS

Snap action contacts are characterised by different tripping and resetting points (differential travel). The displacement speed of the moving contacts is independent to the speed of the operator. This feature ensures satisfactory electrical performance in applications involving low speed actuators.

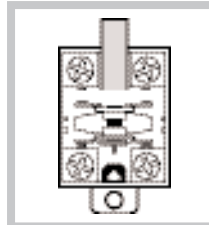

Unactuated state

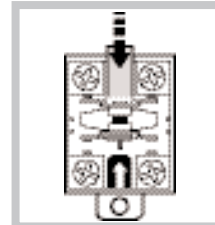

Approach travel

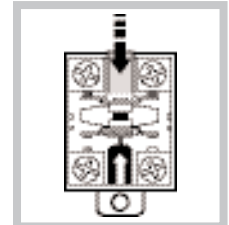

Positive opening

SLOW-BREAK CONTACTS

Slow break contacts are characterised by identical tripping and resetting points. The displacement speed of the moving contacts is equal, or proportional, to the speed of the operator. The opening distance is also dependent on the distance travelled by the operator.

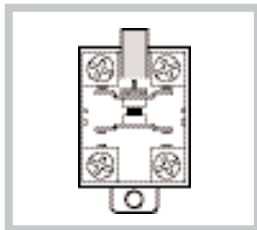

Contact in stand-by

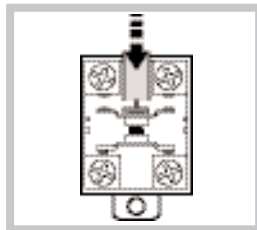

Contact activated

CONTACT BLOCKS CONFIGURATION

ACCORDING TO IEC/EN60947-5-1

Contact blocks with 4 terminals must be marked with Za or Zb symbols as shown in the picture below.

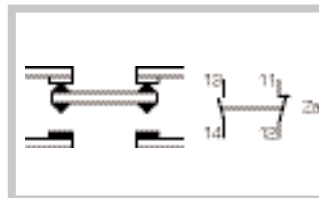

Contacts with same polarity

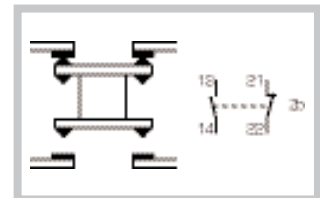

The two moving contacts are electrically insulated

APPLICATIONS

AC-15: control of an electromagnet on a.c., test 10 Ie/Ie.

AC-13: control of an electromagnet on d.c., test Ie/Ie.

TERMINALS

For limit switches with metal housing, the fixing point of the earth conductor must be marked and must be positioned inside the housing next to the cable entry.

Limit Switches

FA - FT - FT1R - Safety - FCT - Astra Series Terminology



TECHNO-CONTROL EQUIPMENT

MINIMUM OPENING FORCE/MOMENTUM

It is the minimum force/momentum that must be applied by the actuator for the contacts to trip.

MINIMUM POSITIVE OPENING FORCE/MOMENTUM

It is the minimum force/momentum that must be applied by the actuator to guarantee the positive opening of NC contacts.

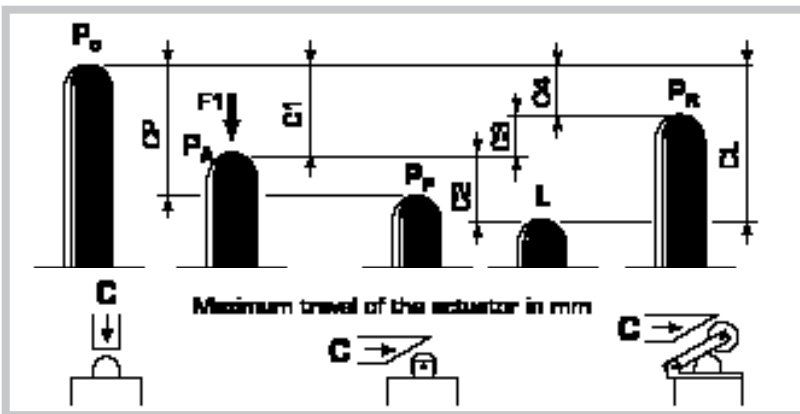

- P₀** Rest position
Position of the actuator when no external force is applied.

- P_A** Tripping point of contact
Position of the actuator, with force F1 applied, in which the contacts leave the stand-by position.

- P_o** Positive opening position
Position of the actuator when there is positive opening.

- L** Maximum travel position
Maximum travel of the actuator when the force F1 is applied.

- P_R** Resetting position
Position of the actuator when the contacts are back in their non actuated position.

- C₁** Tripping travel
Distance between the P₀ and P_A positions.

- C_o** Positive opening tripping travel
Minimum travel of the actuator from the P₀ position to guarantee positive opening of NC contacts.

- C₂** Extra tripping travel
Distance between P_A and the maximum travel L.

- C₁** Maximum travel
Distance between P₀ and the maximum travel L.

- C₃** Differential travel (C1-C4)
Distance between P_A and P_R

- C₄** Resetting travel
Distance between P_R and P₀

NOTE: for slow-break contacts, C3=01, C1-1=Tripping and resetting travel of contacts 21-22, C1-2= Tripping and resetting travel of contacts 13-14

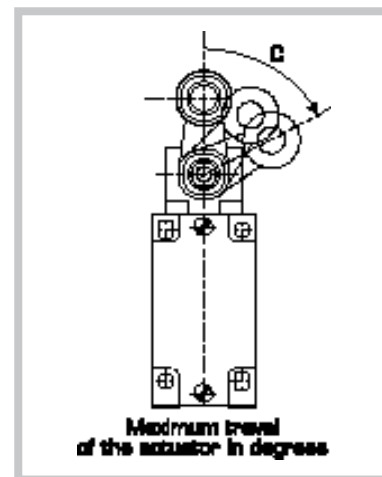

Tripping travel for snap-action contacts



Tripping travel for slow-break contacts

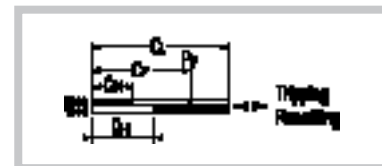

Examples

FA134Z11
(snap-action contacts)



Tripping travel in mm/
cam linear movement



FA138Z11
(snap-action contacts)



Tripping travel in degrees/
lever rotary movement



FA131X11
(slow break contacts)



Tripping travel in mm/
plunger linear movement



Limit Switches

FA1 Series

IP66 die-cast aluminium type

1 cable entry
M16x1.5



FA131



FA134



FA132



FA133

TYPE OF OPERATOR	SHORT STEEL END PLUNGER	STEEL ROLLER PLUNGER	PA ROLLER LEVER PLUNGER HORIZONTAL ACTUATION	PA ROLLER LEVER PLUNGER VERTICAL ACTUATION
Standard – Positive opening NC contacts	EN50047	EN50047	-	-
Minimum tripping force	15	12	7	7
Minimum positive opening force	30	30	24	24
Z11 1NC-1NO Snap action Zb	FA131Z11 	FA134Z11 	FA132Z11 	FA133Z11
X11 1NC-1NO Slow break Zb	FA131X11 	FA134X11 	FA132X11 	FA133X11
Y11 1NC-1NO overlapping Slow break Zb	FA131Y11 	FA134Y11 	FA132Y11 	FA133Y11
Z02 2NC Snap action Zb	FA131Z02 	FA134Z02 	FA132Z02 	FA133Z02
W02 2NC Slow break Zb	FA131W02 	FA134W02 	FA132W02 	FA133W02
W20 2NO Slow break Zb	FA131W20 	FA134W20 	FA132W20 	FA133W20
WEIGHT gr. – MIN. PACK QTY.	168 gr. 1 pcs.	175 gr. 1 pcs.	186 gr. 1 pcs.	186 gr. 1 pcs.

DIMENSIONS

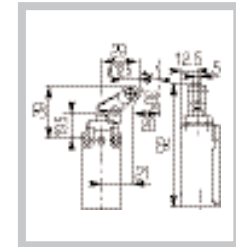
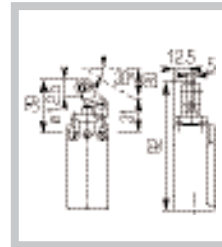
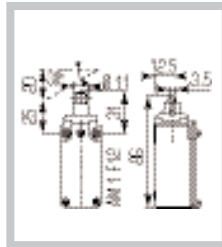
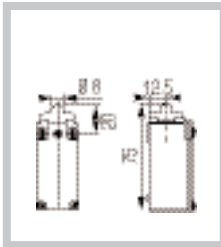
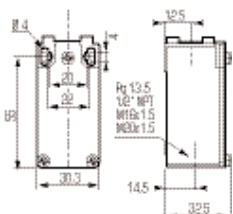

Limit Switches

FA1 Series

IP66 die-cast aluminium type



TECHNO-CONTROL EQUIPMENT

1 cable entry
M16x1.5



FA138



FA141



FA139



FA140

TYPE OF OPERATOR	18 Ø PA ROLLER LEVER	50 Ø RUBBER ROLLER LEVER	VARIABLE LENGTH 18 Ø PA ROLLER LEVER	VARIABLE LENGTH 50 Ø RUBBER ROLLER LEVER
Standard - Positive opening NC contacts	-	-	-	-
Minimum tripping force	0.10	0.10	0.10	0.10
Minimum positive opening force	0.32	-	-	-
Z11 1NC-1NO Snap action Zb	FA138Z11 	FA141Z11 	FA139Z11 	FA140Z11
X11 1NC-1NO Slow break Zb	FA138X11 	FA141X11 	FA139X11 	FA140X11
Y11 1NC-1NO Slow break overlapping Zb	FA138Y11 	FA141Y11 	FA139Y11 	FA140Y11
Z02 2NC Snap action Zb	FA138Z02 	FA141Z02 	FA139Z02 	FA140Z02
W02 2NC Slow break Zb	FA138W02 	FA141W02 	FA139W02 	FA140W02
W20 2NO Slow break Zb	FA138W20 	FA141W20 	FA139W20 	FA140W20

WEIGHT gr. - MIN. PACK QTY.

235 gr. 1 pcs.

255 gr. 1 pcs.

245 gr. 1 pcs.

265 gr. 1 pcs.

DIMENSIONS

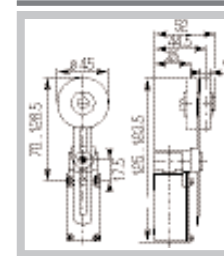
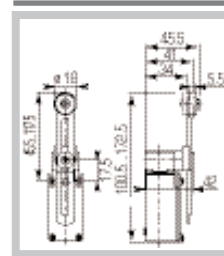
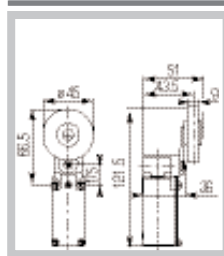
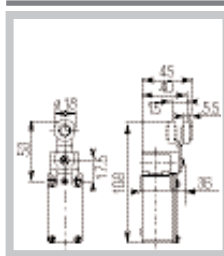
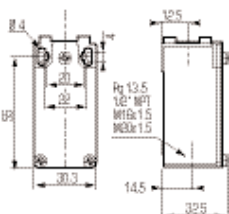

Limit Switches

FA1 Series

IP66 die-cast aluminium type

1 cable entry
M16x1.5



FA135



FA136

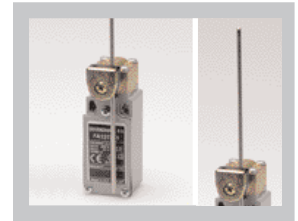

FA137

TYPE OF OPERATOR	SPRING LEVER WITH TIP IN PA	"CAT'S WHISKER"	3 Ø STEEL ROD LEVER
Standard - Positive opening NC contacts	-	-	-
Minimum tripping force	0.10	0.10	0.10
Minimum positive opening force	-	-	-
Z11 1NC-1NO Snap action Zb	FA135Z11 	FA136Z11 	FA137Z11
X11 1NC-1NO Slow break Zb	FA135X11 	FA136X11 	FA137X11
Y11 1NC-1NO Slow break overlapping Zb	FA135Y11 	FA136Y11 	FA137Y11
Z02 2NC Snap action Zb	FA135Z02 	FA136Z02 	FA137Z02
W02 2NC Slow break Zb	FA135W02 	FA136W02 	FA137W02
W20 2NO Slow break Zb	FA135W20 	FA136W20 	FA137W20

WEIGHT gr. - MIN. PACK QTY.

235 gr. 1 pcs.

255 gr. 1 pcs.

245 gr. 1 pcs.

DIMENSIONS

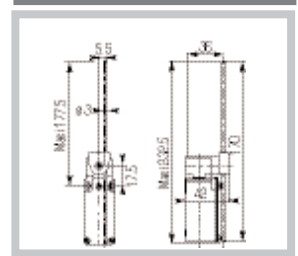
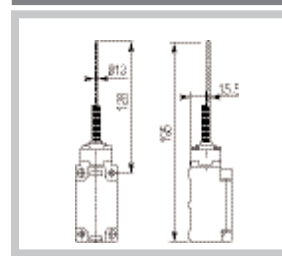
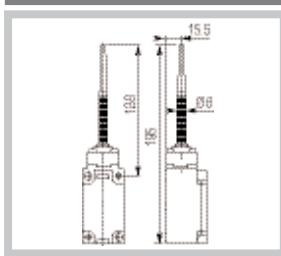
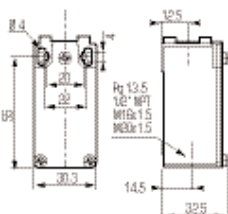

Limit Switches

FA3 Series

IP66 die-cast aluminium type



TECHNO-CONTROL EQUIPMENT

3 cable entries
M16x1.5



FA331



FA334



FA332

TYPE OF OPERATOR	SHORT STEEL END PLUNGER	SHORT STEEL ROLLER PLUNGER	PA ROLLER LEVER PLUNGER HORIZONTAL ACTUATION
Standard - Positive opening NC contacts	-	-	-
Minimum tripping force	15	12	7
Minimum positive opening force	30	30	24
Z11 Snap action 1NC-1NO Zb	FA331Z11 	FA334Z11 	FA332Z11
X11 Slow break 1NC-1NO Zb	FA331X11 	FA334X11 	FA332X11
Y11 Slow break 1NC-1NO overlapping Zb	FA331Y11 	FA334Y11 	FA332Y11
Z02 Snap action 2NC Zb	FA331Z02 	FA334Z02 	FA332Z02
W02 Slow break 2NC Zb	FA331W02 	FA334W02 	FA332W02
W20 Slow break 2NO Zb	FA331W20 	FA334W20 	FA332W20

WEIGHT gr. - MIN. PACK QTY.

270 gr. 1 pcs.

280 gr. 1 pcs.

290 gr. 1 pcs.

DIMENSIONS

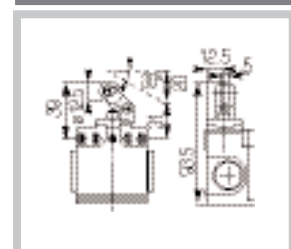
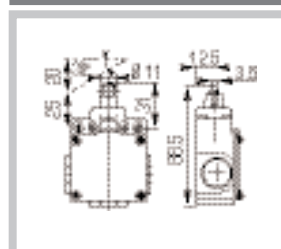
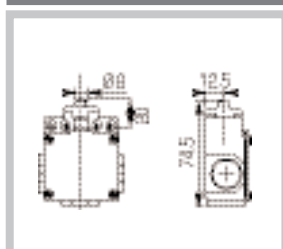
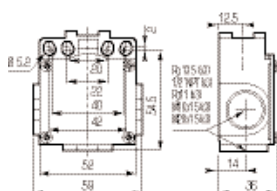

Limit Switches

FA3 Series

IP66 die-cast aluminium type

3 cable entries
M16x1.5

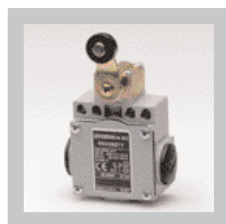

FA338



FA341

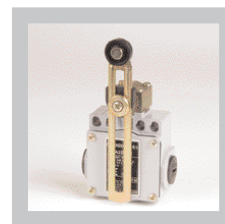

FA339

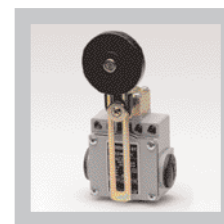

FA340

TYPE OF OPERATOR	18 Ø PA ROLLER LEVER	50 Ø RUBBER ROLLER LEVER	VARIABLE LENGTH 18 Ø PA ROLLER LEVER	VARIABLE LENGTH 50 Ø RUBBER ROLLER LEVER
Standard - Positive opening NC contacts	-	-	-	-
Minimum tripping force	0.10	0.10	0.10	0.10
Minimum positive opening force	0.32	-	-	-
Z11 1NC-1NO Snap action Zb	FA338Z11 	FA341Z11 	FA339Z11 	FA340Z11
X11 1NC-1NO Slow break Zb	FA338X11 	FA341X11 	FA339X11 	FA340X11
Y11 1NC-1NO Slow break overlapping Zb	FA338Y11 	FA341Y11 	FA339Y11 	FA340Y11
Z02 2NC Snap action Zb	FA338Z02 	FA341Z02 	FA339Z02 	FA340Z02
W02 2NC Slow break Zb	FA338W02 	FA341W02 	FA339W02 	FA340W02
W20 2NO Slow break Zb	FA338W20 	FA341W20 	FA339W20 	FA340W20
WEIGHT gr. - MIN. PACK QTY.	325 gr. 1 pcs.	345 gr. 1 pcs.	335 gr. 1 pcs.	355 gr. 1 pcs.

DIMENSIONS

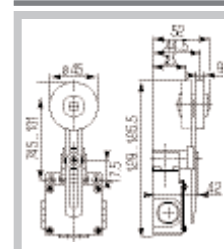
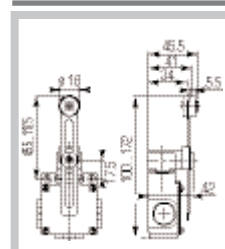
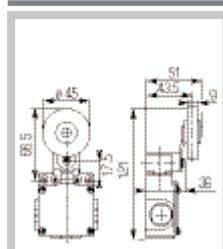
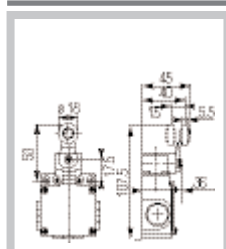
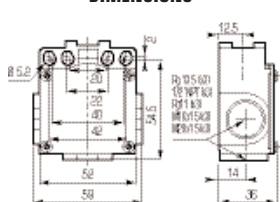

Limit Switches

FA3 Series

IP66 die-cast aluminium type



TECHNO-CONTROL EQUIPMENT

3 cable entries
M16x1.5



FA335



FA336

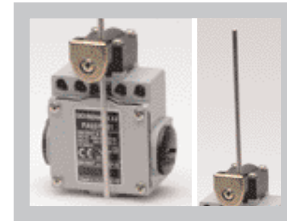

FA337

TYPE OF OPERATOR	SPRING LEVER WITH TIP IN PA	"CAT'S WHISKER"	VARIABLE LENGTH 3 Ø STEEL ROD LEVER
Standard - Positive opening NC contacts	-	-	-
Minimum tripping force	0.10	0.10	0.10
Minimum positive opening force	-	-	-
Z11 1NC-1NO Snap action Zb	FA335Z11 	FA336Z11 	FA337Z11
X11 1NC-1NO Slow break Zb	FA335X11 	FA336X11 	FA337X11
Y11 1NC-1NO Slow break overlapping Zb	FA335Y11 	FA336Y11 	FA337Y11
Z02 2NC Snap action Zb	FA335Z02 	FA336Z02 	FA337Z02
W02 2NC Slow break Zb	FA335W02 	FA336W02 	FA337W02
W20 2NO Slow break Zb	FA335W20 	FA336W20 	FA337W20

WEIGHT gr. - MIN. PACK QTY.

305 gr. 1 pcs.

320 gr. 1 pcs.

380 gr. 1 pcs.

DIMENSIONS

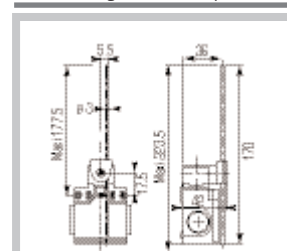
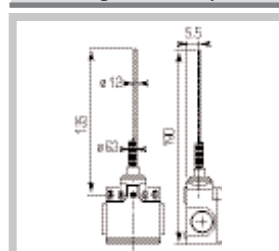
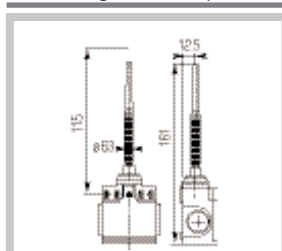
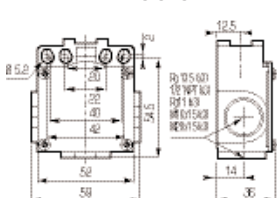

Limit Switches

FT1 Series

IP65 □ thermoplastic type

1 cable entry
M16x1.5



FT131



FT1P31



FT134



FT132

TYPE OF OPERATOR	SHORT STEEL END PLUNGER	SHORT STEEL END PLUNGER WITH PROTECTIVE BOOT	PA ROLLER LEVER PLUNGER	PA ROLLER LEVER PLUNGER HORIZONTAL ACTUATION
Standard - Positive opening NC contacts	EN50047	EN50047	EN50047	EN50047
Minimum tripping force	15	15	12	7
Minimum positive opening force	30	30	30	24

Z11 1NC-1NO	Snap action	FT131Z11	FT1P31Z11	FT134Z11	FT132Z11
	Zb				

X11 1NC-1NO	Slow break	FT131X11	FT1P31X11	FT134X11	FT132X11
	Zb				

Y11 1NC-1NO overlapping	Slow break	FT131Y11	FT1P31Y11	FT134Y11	FT132Y11
	Zb				

Z02 2NC	Snap action	FT131Z02	FT1P31Z02	FT134Z02	FT132Z02
	Zb				

W02 2NC	Slow break	FT131W02	FT1P31W02	FT134W02	FT132W02
	Zb				

W20 2NO	Slow break	FT131W20	FT1P31W20	FT134W20	FT132W20
	Zb				

WEIGHT gr. - MIN. PACK QTY.	60 gr. 1 pcs.	60 gr. 1 pcs.	62 gr. 1 pcs.	65 gr. 1 pcs.
------------------------------------	---------------	---------------	---------------	---------------

DIMENSIONS	FT131	FT1P31	FT134	FT132

Limit Switches

FT1 Series

IP65 □ thermoplastic type



TECHNO-CONTROL EQUIPMENT

1 cable entry
M16x1.5



FT1P32



FT133



FT1P33



FT138

TYPE OF OPERATOR	PA ROLLER LEVER PLUNGER WITH PROTECTIVE BOOT HORIZONTAL ACTUATION	PA ROLLER LEVER PLUNGER VERTICAL ACTUATION	PA ROLLER LEVER PLUNGER WITH PROTECTIVE BOOT VERTICAL ACTUATION	18 Ø PA ROLLER LEVER
Standard - Positive opening NC contacts	EN50047	EN50047	EN50047	EN50047
Minimum tripping force N	7	7	7	0.10
Minimum positive opening force N	24	24	24	0.32
Z11 Snap action 1NC-1NO	FT1P32Z11	FT133Z11	FT1P33Z11	FT138Z11
X11 Slow break 1NC-1NO	FT1P32X11	FT133X11	FT1P33X11	FT138X11
Y11 Slow break 1NC-1NO overlapping	FT1P32Y11	FT133Y11	FT1P33Y11	FT138Y11
Z02 Snap action 2NC	FT1P32Z02	FT133Z02	FT1P33Z02	FT138Z02
W02 Slow break 2NC	FT1P32W02	FT133W02	FT1P33W02	FT138W02
W20 Slow break 2NO	FT1P32W20	FT133W20	FT1P33W20	FT138W20
WEIGHT gr. - MIN. PACK QTY.	65 gr. 1 pcs.	65 gr. 1 pcs.	65 gr. 1 pcs.	80 gr. 1 pcs.

DIMENSIONS

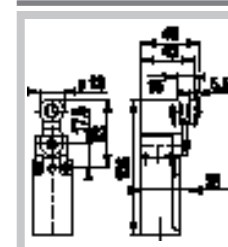
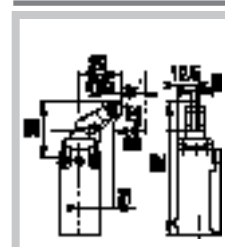
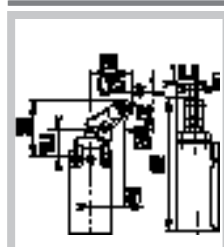
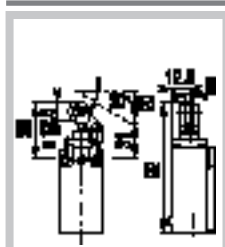
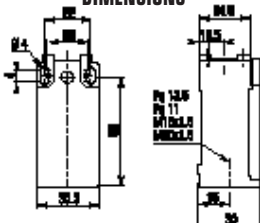

Limit Switches

FT1 Series

IP65 □ thermoplastic type

1 cable entry
M16x1.5



FT141



FT139



FT140



FT135

TYPE OF OPERATOR	50 Ø RUBBER ROLLER LEVER	VARIABLE LENGTH 18 Ø PA ROLLER LEVER	VARIABLE LENGTH 50 Ø RUBBER ROLLER LEVER	SPRING LEVER WITH TIP IN PA
Standard - Positive opening NC contacts	-	-	-	EN50047
Minimum tripping force N	0.10	0.10	0.10	0.12
Minimum positive opening force N	-	-	-	-
Z11 Snap action 1NC-1NO Zb	FT141Z11 	FT139Z11 	FT140Z11 	FT135Z11
X11 Slow break 1NC-1NO Zb	FT141X11 	FT139X11 	FT140X11 	FT135X11
Y11 Slow break 1NC-1NO overlapping Zb	FT141Y11 	FT139Y11 	FT140Y11 	FT135Y11
Z02 Snap action 2NC Zb	FT141Z02 	FT139Z02 	FT140Z02 	FT135Z02
W02 Slow break 2NC Zb	FT141W02 	FT139W02 	FT140W02 	FT135W02
W20 Slow break 2NO Zb	FT141W20 	FT139W20 	FT140W20 	FT135W20
WEIGHT gr. - MIN. PACK QTY.	95 gr. 1 pcs.	105 gr. 1 pcs.	125 gr. 1 pcs.	70 gr. 1 pcs.

DIMENSIONS	95 gr. 1 pcs.	105 gr. 1 pcs.	125 gr. 1 pcs.	70 gr. 1 pcs.

Limit Switches

FT1 Series

IP65 □thermoplastic type



TECHNO-CONTROL EQUIPMENT

1 cable entry
M16x1.5



FT136

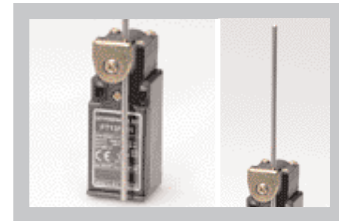

FT137

TYPE OF OPERATOR	"CAT'S WHISKER"	VARIABLE LENGTH 3 Ø STEEL ROD LEVER
Standard - Positive opening NC contacts	-	-
Minimum tripping force N	0.12	0.12
Minimum positive opening force N	-	-
Z11 1NC-1NO Snap action Zb	FT136Z11 	FT137Z11
X11 1NC-1NO Slow break Zb	FT136X11 	FT137X11
Y11 1NC-1NO Slow break overlapping Zb	FT136Y11 	FT137Y11
Z02 2NC Snap action Zb	FT136Z02 	FT137Z02
W02 2NC Slow break Zb	FT136W02 	FT137W02
W20 2NO Slow break Zb	FT136W20 	FT137W20

WEIGHT gr. - MIN. PACK QTY.

80 gr.

1 pcs.

105 gr.

1 pcs.

DIMENSIONS

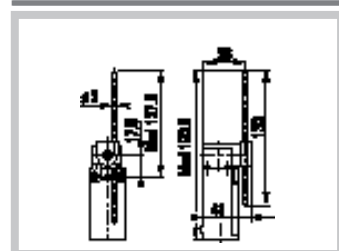
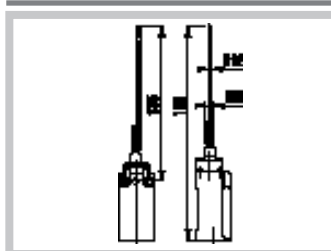
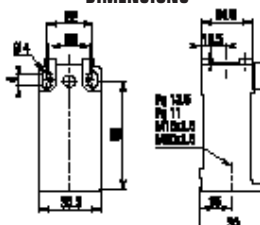

Limit Switches

FT2 Series

IP65 □ thermoplastic type

2 cable entries
M16x1.5

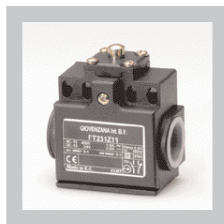

FT231



FT2P31

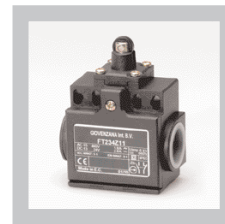

FT234

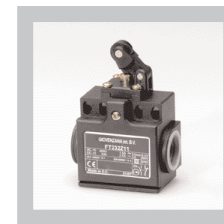

FT232

TYPE OF OPERATOR	SHORT STEEL END PLUNGE	SHORT STEEL END PLUNGER WITH PROTECTIVE BOOT	PA ROLLER LEVER PLUNGER	PA ROLLER LEVER PLUNGER HORIZONTAL ACTUATION
Standard - Positive opening NC contacts	-	-	-	-
Minimum tripping force N	15	15	12	7
Minimum positive opening force N	30	30	30	24
Z11 Snap action 1NC-1NO Zb	FT231Z11 	FT2P31Z11 	FT234Z11 	FT232Z11
X11 Slow break 1NC-1NO Zb	FT231X11 	FT2P31X11 	FT234X11 	FT232X11
Y11 Slow break 1NC-1NO overlapping Zb	FT231Y11 	FT2P31Y11 	FT234Y11 	FT232Y11
Z02 Snap action 2NC Zb	FT231Z02 	FT2P31Z02 	FT234Z02 	FT232Z02
W02 Slow break 2NC Zb	FT231W02 	FT2P31W02 	FT234W02 	FT232W02
W20 Slow break 2NO Zb	FT231W20 	FT2P31W20 	FT234W20 	FT232W20
WEIGHT gr. - MIN. PACK QTY.	100 gr. 1 pcs.	100 gr. 1 pcs.	105 gr. 1 pcs.	105 gr. 1 pcs.

DIMENSIONS

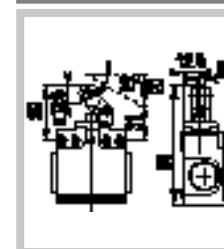
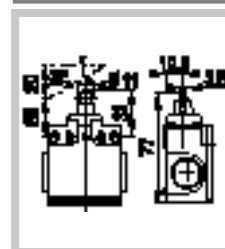
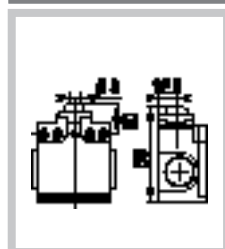
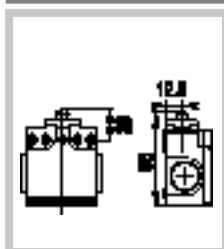
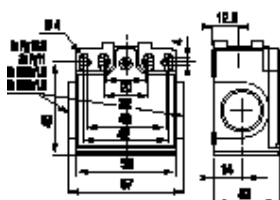

Limit Switches

FT2 Series

IP65 □ thermoplastic type



TECHNO-CONTROL EQUIPMENT

2 cable entries
M16x1.5



FT2P32



FT238



FT239



FT240

TYPE OF OPERATOR	PA ROLLER LEVER PLUNGER WITH PROTECTIVE BOOT HORIZONTAL ACTUATION	18 Ø PA ROLLER LEVER	VARIABLE LENGTH 18 Ø PA ROLLER LEVER	VARIABLE LENGTH 50 Ø RUBBER ROLLER LEVER
Standard - Positive opening NC contacts	-	-	-	-
Minimum tripping force N	7	0.10	0.10	0.10
Minimum positive opening force N	24	0.32	-	-
Z11 Snap action 1NC-1NO	FT2P32Z11	FT238Z11	FT239Z11	FT240Z11
X11 Slow break 1NC-1NO	FT2P32X11	FT238X11	FT239X11	FT240X11
Y11 Slow break 1NC-1NO overlapping	FT2P32Y11	FT238Y11	FT239Y11	FT240Y11
Z02 Snap action 2NC	FT2P32Z02	FT238Z02	FT239Z02	FT240Z02
W02 Slow break 2NC	FT2P32W02	FT238W02	FT239W02	FT240W02
W20 Slow break 2NO	FT2P32W20	FT238W20	FT239W20	FT240W20

WEIGHT gr. - MIN. PACK QTY.

105 gr. 1 pcs.

125 gr. 1 pcs.

125 gr. 1 pcs.

155 gr. 1 pcs.

DIMENSIONS

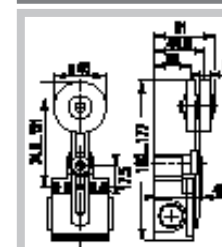
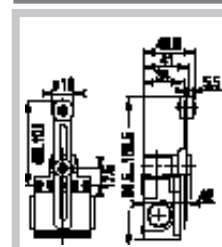
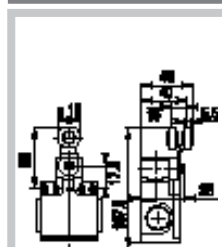
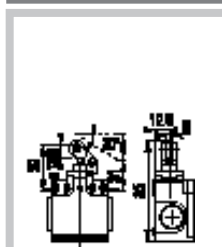
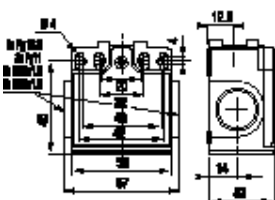

Limit Switches

FT2 Series

IP65 □ thermoplastic type

2 cable entries
M16x1.5

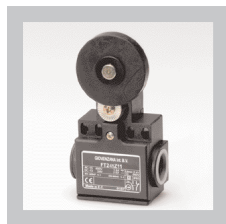

FT241



FT235



FT236



FT237

TYPE OF OPERATOR	50 Ø RUBBER ROLLER LEVER	SPRING LEVER WITH TIP IN PA	"CAT'S WHISKER"	VARIABLE LENGTH 3 Ø STEEL ROD LEVER
Standard - Positive opening NC contacts	-	-	-	-
Minimum tripping force N	0.10	0.10	0.10	0.10
Minimum positive opening force N	-	0.32	-	-
Z11 Snap action 1NC-1NO 	FT241Z11 	FT235Z11 	FT236Z11 	FT237Z11
X11 Slow break 1NC-1NO 	FT241X11 	FT235X11 	FT236X11 	FT237X11
Y11 Slow break 1NC-1NO overlapping 	FT241ZY11 	FT235Y11 	FT236Y11 	FT237Y11
Z02 Snap action 2NC 	FT241Z02 	FT235Z02 	FT236Z02 	FT237Z02
W02 Slow break 2NC 	FT241W02 	FT235W02 	FT236W02 	FT237W02
W20 Slow break 2NO 	FT241W20 	FT235W20 	FT236W20 	FT237W20
WEIGHT gr. - MIN. PACK QTY.	145 gr. 1 pcs.	135 gr. 1 pcs.	110 gr. 1 pcs.	130 gr. 1 pcs.

DIMENSIONS

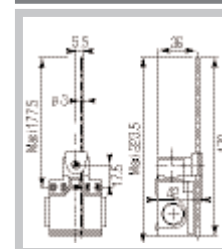
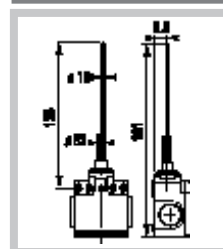
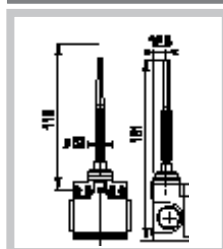
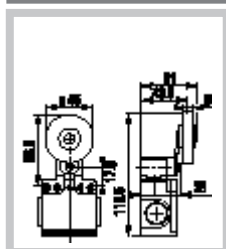
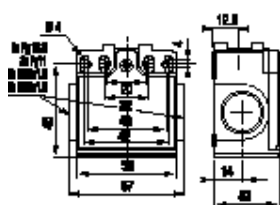

Limit Switches

FT1R Series with reset

IP65 □ thermoplastic type



TECHNO-CONTROL EQUIPMENT

1 cable entry
M16x1.5



FT1R31



FT1R34



FT1R32



FT1R33

TYPE OF OPERATOR	SHORT STEEL END PLUNGER	PA ROLLER PLUNGER	PA ROLLER LEVER PLUNGER HORIZONTAL ACTUATION	PA ROLLER LEVER PLUNGER VERTICAL ACTUATION
Standard - Positive opening NC contacts	-	-	-	-
Minimum tripping force N	15	12	7	7
Minimum positive opening force N	30	30	24	24
Snap action Z11 1NC-1NO	FT1R31Z11	FT1R34Z11	FT1R32Z11	FT1R33Z11
Slow break X11 1NC-1NO	FT1R31X11	FT1R34X11	FT1R32X11	FT1R33X11
Slow break Y11 1NC-1NO overlapping	FT1R31Y11	FT1R34Y11	FT1R32Y11	FT1R33Y11
Snap action Z02 2NC	FT1R31Z02	FT1R34Z02	FT1R32Z02	FT1R33Z02
Slow break W02 2NC	FT1R31W02	FT1R34W02	FT1R32W02	FT1R33W02

WEIGHT gr. - MIN. PACK QTY.

75 gr. 1 pcs.

78 gr. 1 pcs.

80 gr. 1 pcs.

80 gr. 1 pcs.

DIMENSIONS

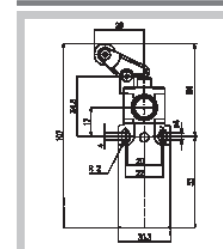
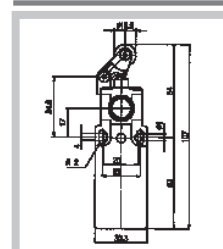
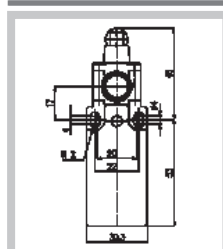
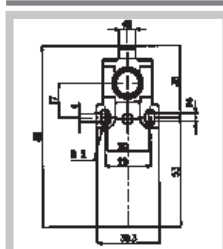
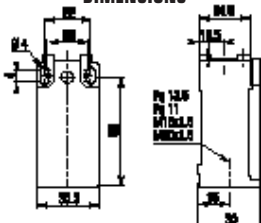

Limit Switches

FT1R Series with reset

IP65 □ thermoplastic type

1 cable entry
M16x1.5



FT1R38



FT1R41



FT1R39



FT1R40

TYPE OF OPERATOR	18 Ø PA ROLLER LEVER	50 Ø RUBBER ROLLER LEVER	VARIABLE LENGTH 18 Ø PA ROLLER LEVER	VARIABLE LENGTH 50 Ø RUBBER ROLLER LEVER
Standard - Positive opening NC contacts	-	-	-	-
Minimum tripping force N	0.10	0.10	0.10	0.10
Minimum positive opening force N	0.32	-	-	-
Snap action	FT1R38Z11	FT1R41Z11	FT1R39Z11	FT1R40Z11
Z11 1NC-1NO 				
Slow break	FT1R38X11	FT1R41X11	FT1R39X11	FT1R40X11
X11 1NC-1NO 				
Slow break overlapping	FT1R38Y11	FT1R41Y11	FT1R39Y11	FT1R40Y11
Y11 1NC-1NO overlapping 				
Snap action	FT1R38Z02	FT1R41Z02	FT1R39Z02	FT1R40Z02
Z02 2NC 				
Slow break	FT1R38W02	FT1R41W02	FT1R39W02	FT1R40W02
W02 2NC 				
WEIGHT gr. - MIN. PACK QTY.	95 gr. 1 pcs.	110 gr. 1 pcs.	120 gr. 1 pcs.	145 gr. 1 pcs.
DIMENSIONS				

Safety Limit Switches

Safety Series - Limit Switches

IP65 □ thermoplastic type



TECHNO-CONTROL EQUIPMENT

1 cable entry
M16x1.5



ST1K1



ST1K61



ST1K71 Zinc Plated Steel Spindle
ST1K72 Stainless Steel Spindle



ST1K8

TYPE OF OPERATOR	90° ADJUSTABLE TURRET HEAD WITH ACTUATOR	ADJUSTABLE STEEL ROTARY LEVER	STEEL SPINDLE	360° ADJUSTABLE TURRET HEAD WITH ACTUATOR
Standard - Positive opening NC contacts	-	-	-	-
Minimum tripping force N	-	-	-	-
Minimum positive opening force N	-	-	-	-
Snap action Z11 1NC-1NO Zb	ST1K1*Z11	ST1K61Z11	Zinc Plated ST1K71Z11 Stainless ST1K72Z11	ST1K8*Z11
Slow break X11 1NC-1NO Zb	ST1K1*X11	ST1K61X11	Zinc Plated ST1K71X11 Stainless ST1K72X11	ST1K8*X11
Slow break Y11 1NC-1NO overlapping Zb	ST1K1*Y11	ST1K61Y11	Zinc Plated ST1K71Y11 Stainless ST1K72Y11	ST1K8*Y11
Snap action Z02 2NC Zb	ST1K1*Z02	ST1K61Z02	Zinc Plated ST1K71Z02 Stainless ST1K72Z02	ST1K8*Z02
Slow break W02 2NC Zb	ST1K1*W02	ST1K61W02	Zinc Plated ST1K71W02 Stainless ST1K72W02	ST1K8*W02
WEIGHT gr. - MIN. PACK QTY.	83 gr. 1 pcs.	96 gr. 1 pcs.	80 gr. 1 pcs.	90 gr. 1 pcs.
DIMENSIONS				

* Include actuator type reference number i.e.: ST1K13Z11

Safety Limit Switches

Safety Series - Limit Switches

IP65 □ thermoplastic type

ACTUATORS



22MM RIGHT-ANGLED ACTUATOR

REFERENCE NO.

3



22MM STRAIGHT ACTUATOR

4



13MM RIGHT-ANGLED ACTUATOR

5



13MM STRAIGHT ACTUATOR

6



SHOCK ABSORBING RIGHT-ANGLED ACTUATOR

REFERENCE NO.

7

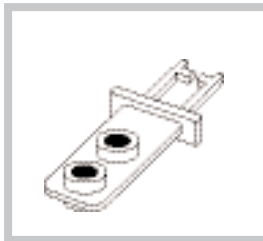

SHOCK ABSORBING STRAIGHT ACTUATOR

8

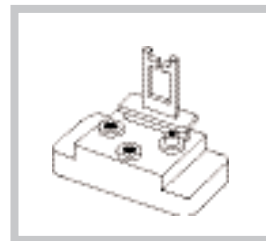

JOINTED KEY ACTUATOR

9

GENERAL CHARACTERISTICS

Safety limit switches are suitable for stopping dangerous machinery movements on opening of machine guards or protective covers. Available with different type of actuators and controls and with adjustable turret heads which can be rotated through 360° in 90° steps, they can be installed with a wide variety of opening mechanisms.

■ Comply with		IEC/EN60947-5-1, UL508		
■ Rated insulation voltage U_i	V	690		
■ Rated impulse withstand voltage U_{imp}	kV	6		
■ Operating frequency	Hz	50		
■ Rated thermal current I_{th}	A	10		
■ Rated operating current I_e :				
	V	24	230	380
AC15: alternate current	A	10	3.1	1,9
	V	24	250	-
DC13: direct current	A	2.8	0.27	-
■ Conditional short circuit withstand		10A gG fuse rating		
■ Electrical shocks withstand IEC 536		class II		
■ Protection rating IEC/EN 60529		IP65		
■ Operating temperature	°C	-25 +70		
■ Category of use UL 508		A600 - Q600		
■ Certifications		UL		

Limit Switches

FA - FT - FT1R Series

Installation and use



TECHNO-CONTROL EQUIPMENT

REVERSE MOUNTING OF THE OPERATING LEVER

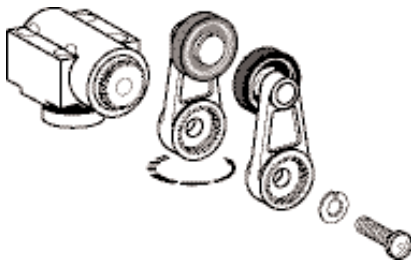

FA - FT - FT1R Series

REST POSITION SETTING THROUGH 10° STEPS

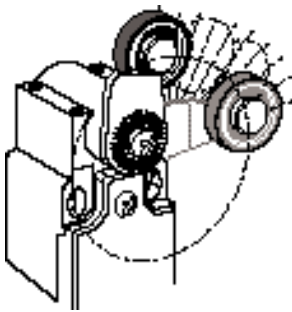

FA - FT - FT1R Series

STEEL PLUNGER

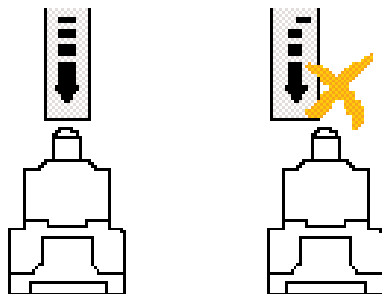

Right

Wrong

PLUNGER OR ROLLER LEVER

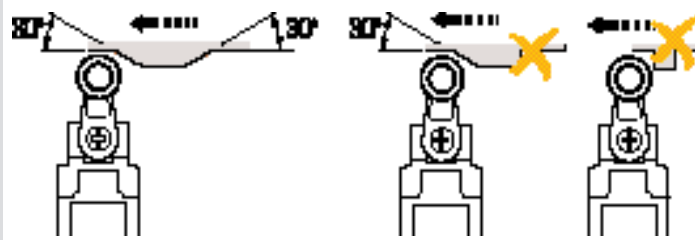

Right

Wrong

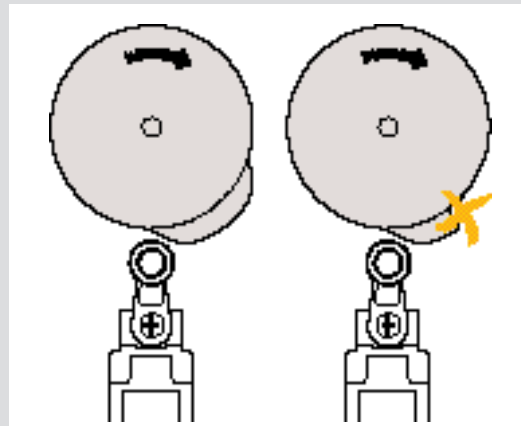

Right

Wrong

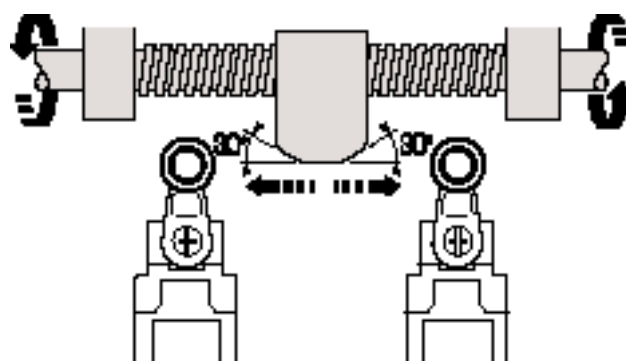

In case of a relatively slow movement of the actuator, snap action contact are recommended

Limit Switches

FA - FT - FT1R Series

Technical data

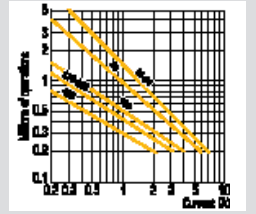
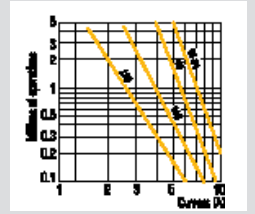
GENERAL CHARACTERISTICS																	
Comply with		IEC947-5-1, EN60947-5-1, UL508, CSA 22.2 n° 14															
Certifications		cUL															
Ambient temperature	°C	Operating -25 +70															
	°C	Storage -30 +80															
Climate protection	IEC68 part 2-3	Hot damp															
	IEC68 part 2-11	Saline fog															
Installation positions		All positions															
Impact resistance	IEC68 part 2-27	50g* (1/2 sinusoidal shock for 11 msec) without replacing contacts															
Vibration resistance	IEC68 part 2-6	25g (10...500 Hz) without replacing contacts >100 msec															
Electrical shocks withstand	IEC536	Class II for FT series - Class I for FA series															
Protection rating	EN60529	IP65 FT series - IP66 - FA series															
Accuracy (measured after 1 million operations)		0.05 FA series - 0.1 FT series (on the making point)															
0.05 Minimum tripping force	m/s	Slow break 0.06 - snap action 0.001															
ELECTRICAL CHARACTERISTICS																	
Rated insulation voltage Ui (IEC/EN60947-1)	V	690 FT series - 400 FA series (3 pollution grade)															
according to UL508 and CSA C22-2 No. 14		600 (designation A600 - Q600)															
Rated impulse withstand voltage Uimp (IEC/EN60947-1)	kV	6															
Rated thermal current Ith (IEC/EN60947-1)	A	10															
Short circuit protection <500 Va.c. - fuses type gG (gI7)	A	10															
Rated operating current Ie:																	
AC-15 (IEC/EN60947-5-1)	24 V - 50/60 Hz A	10															
	120 V - 50/60 Hz A	6															
	230 V - 50/60 Hz A	3.1															
	240 V - 50/60 Hz A	3															
	380 V - 50/60 Hz A	1.9															
DC-13 (IEC/EN60947-5-1)	24 V - 50/60 Hz A	2.8															
	120 V - 50/60 Hz A	0.55															
	230 V - 50/60 Hz A	0.27															
Changeover frequency	cycles/hour	3600															
Load factor		0.5															
Contact insulation resistance	mΩ	25															
Termination type		M3.5 screw clamp terminals (+/-) pozidriv 2															
Earth terminal (FA series only)		M3.5 screw clamp terminals (+/-) pozidriv 2															
Terminal capacity solid/flexible conductor	1 or 2 mm ²	0.75...2.5															
Terminal referencing		according to EN50013															
Mechanical life	millions of operations	15 FA 31; 32; 33															
		10 FT 34; 37; 38...41															
		>5 FT P31...P33; 35; 36															
Electrical life (according to IEC/EN60947-5-1)		AC-15 and DC-13 categories of use (0.5 load factor according to the diagrams below)															
AC-15 Snap action 	AC-15 Slow break 	<table border="1"> <thead> <tr> <th>DC-13</th> <th>Snap action</th> <th>Slow break</th> </tr> </thead> <tbody> <tr> <td colspan="3">Breaking capacity for a duration of 5 millions cycles</td> </tr> <tr> <td>Voltage 24 V</td> <td>9.5 W</td> <td>12 W</td> </tr> <tr> <td>Voltage 48 V</td> <td>6.8 W</td> <td>9 W</td> </tr> <tr> <td>Voltage 110 V</td> <td>3.6 W</td> <td>6 W</td> </tr> </tbody> </table>	DC-13	Snap action	Slow break	Breaking capacity for a duration of 5 millions cycles			Voltage 24 V	9.5 W	12 W	Voltage 48 V	6.8 W	9 W	Voltage 110 V	3.6 W	6 W
DC-13	Snap action	Slow break															
Breaking capacity for a duration of 5 millions cycles																	
Voltage 24 V	9.5 W	12 W															
Voltage 48 V	6.8 W	9 W															
Voltage 110 V	3.6 W	6 W															
* 25gr for FA.40 and FT.40																	

Limit Switches

Pre-wired FCT series

IP67 □ thermoplastic type



TECHNO-CONTROL EQUIPMENT

Cable: PVC UL
5x0.75 mm²
2 m length
Outlet : horizontal .L.
vertical .V.



.01.



.02.

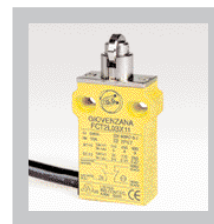

.03.

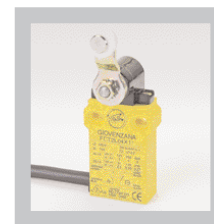

.04.

TYPE OF OPERATOR

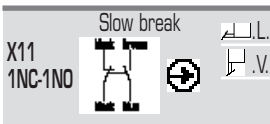

WEIGHT gr. – MIN. PACK QTY.

DIMENSIONS

STEEL END PLUNGER

FCT2L01X11
FCT2V01X11



75 gr. 1 pcs.

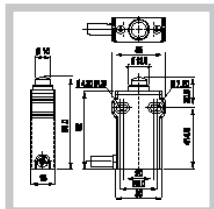

ROLLER PLUNGER

FCT2L02X11
FCT2V02X11



78 gr. 1 pcs.

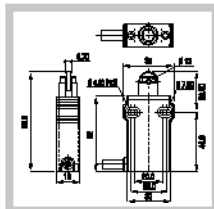

90° ROLLER PLUNGER

FCT2L03X11
FCT2V03X11



80 gr. 1 pcs.

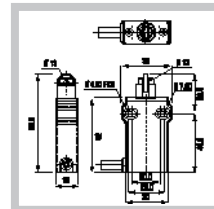

14 Ø POM ROLLER LEVER

FCT2L04X11
FCT2V04X11



80 gr. 1 pcs.

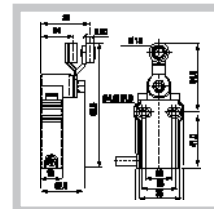

Cable: PVC UL
5x0.75 mm²
2 m length
Outlet : horizontal .L.
vertical .V.



.06.



.07.



.08.

TYPE OF OPERATOR

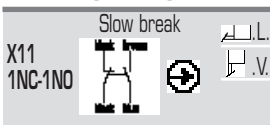

WEIGHT gr. – MIN. PACK QTY.

DIMENSIONS

STEEL END PLUNGER WITH THREADED FLANGE

FCT2L06X11
FCT2V06X11



75 gr. 1 pcs.

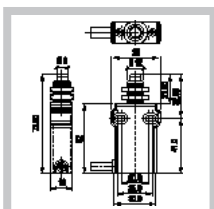

ROLLER PLUNGER WITH THREADED FLANGE

FCT2L07X11
FCT2V07X11



78 gr. 1 pcs.

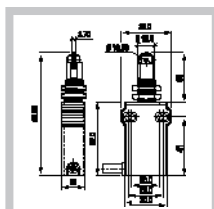

90° ROLLER PLUNGER WITH THREADED FLANGE

FCT2L08X11
FCT2V08X11



80 gr. 1 pcs.

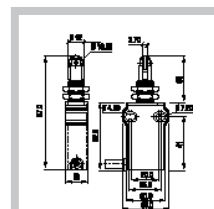

CHARACTERISTICS

IEC/EN60947-5-1
Rated insulation voltage
U_i/500V
Rated thermal current I_{th} 10A
Rated operating current I_e:
AC15
U_e V 120 250 400
I_e A 6 4 3
DC13
U_e V 24 125 250
I_e A 2,5 0,55 0,27
UL508
General use
Designation A300-G300
Operating temperature -25 +70 °C
Self extinguishing body VO

Limit Switches

Astra Series

IP54 universal type

2 cable entries
with cable gland



TYPE OF OPERATOR	STEEL ROLLER PLUNGER	20 Ø PA ROLLER LEVER	35 Ø PA ROLLER LEVER	ROLLER PLUNGER AND LEVER WITH RESET
Slow break 1NC-1NO 	30303061 	30303073 	30303025 	30303092
Slow break 1NC-1NO overlapping 	30303062 	30303074 	30303026 	30303098
WEIGHT gr. – MIN. PACK QTY.	130 gr. 1 pcs.	160 gr. 1 pcs.	200 gr. 1 pcs.	180 gr. 1 pcs.
DIMENSIONS				

GENERAL CHARACTERISTICS

Comply with	IEC/EN60947-5-1						
Rated insulation voltage U_i	500 (pollution class 3)						
Rated impulse withstand voltage U_{imp}	4						
Operating frequency	50/60						
Rated thermal current I_{th}	10						
Rated operating current I_e :							
AC-15 alterate current	<table border="1"> <tr> <td>110</td> <td>230</td> <td>380</td> </tr> <tr> <td>8</td> <td>8</td> <td>6</td> </tr> </table>	110	230	380	8	8	6
110	230	380					
8	8	6					
Contact type	Slow break double gap contacts						
Protection rating	IP54						
Ambient temperature	Operating -25 +55 Storage -30 +70						
Termination type	Screw clamp terminals						
Materials	Housing in reinforced PA – PC lid Nickel brass plunger – Reinforced PC lever						

Micro Switches

MFI Series

Table of contents



TECHNO-CONTROL EQUIPMENT

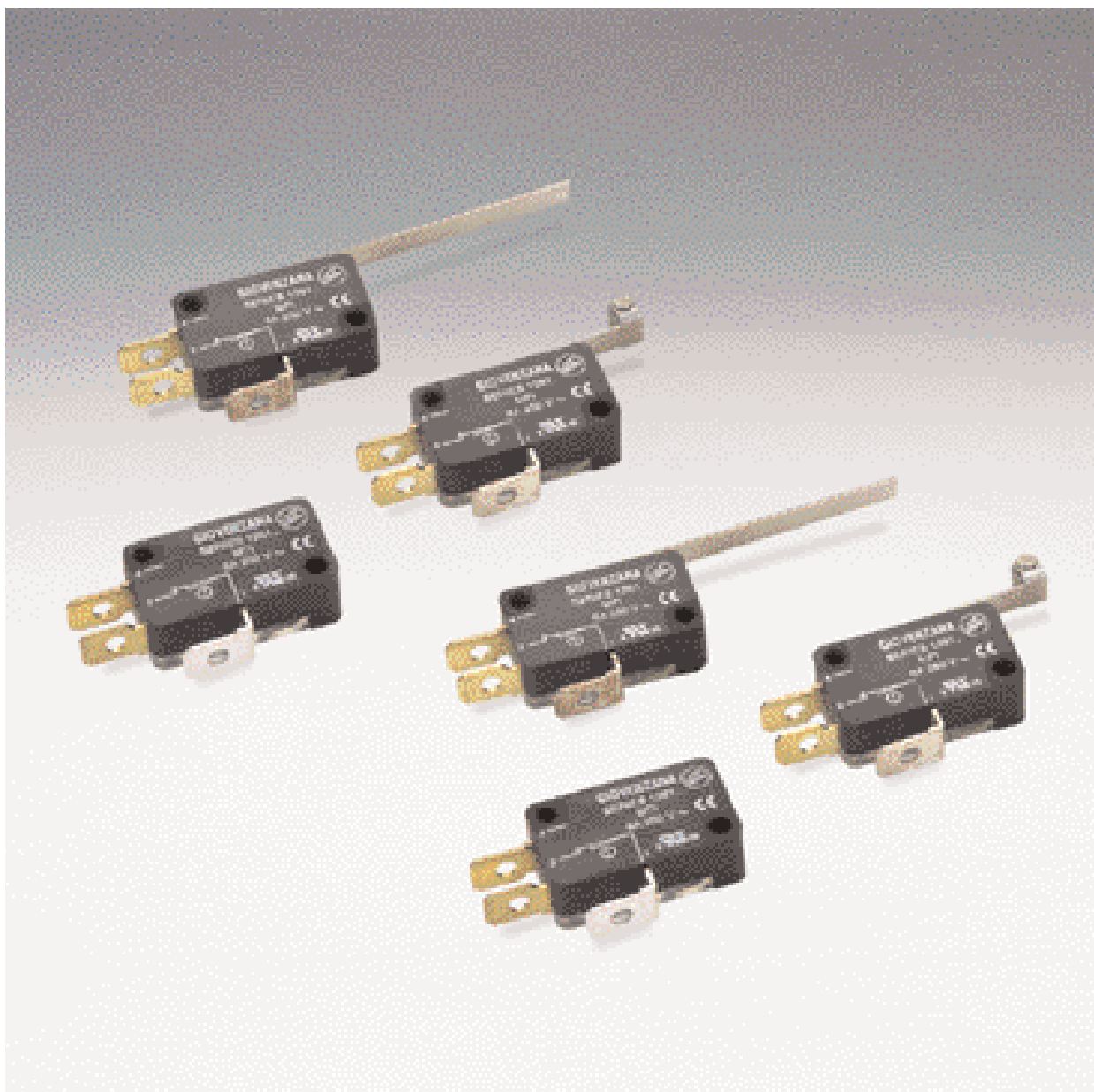

Standard micro switches with self cleaning contacts
Supplied with operator.

TABLE OF CONTENTS

■ MFI Series

pag.96

Micro Switches

MFI Series

DIN 41635A - 6.3x0.8 connectors



- Changeover contacts
- High reliability snap action contacts
- Silver alloy self cleaning contacts
- Positive opening NC contact
- 7 versions available
- Certifications:

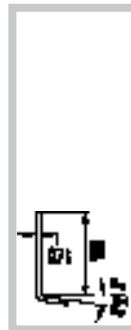
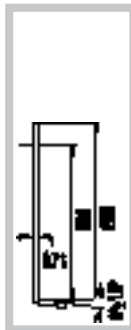
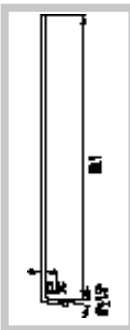
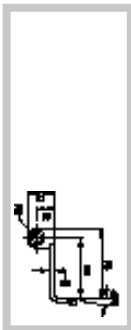
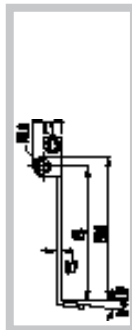
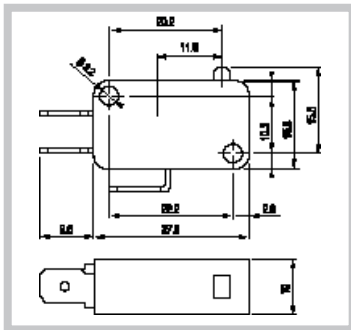

		PIN PLUNGER	LONG ROLLER LEVER	SIMULATED ROLLER LEVER	ROLLER LEVER	LONG LEVER	LEVER	SHORT LEVER
1NC-1NO								
Snap action								
	0.8x6.3	MFI	MFI.1	MFI.2	MFI.3	MFI.4	MFI.5	MFI.6
Operating force	N	4.5	3.2	3.2	4.5	1.3	3.2	4.5
Resetting force	N	1.9	1.2	1.2	1.9	0.15	1.2	1.9
Max pre travel PT	mm	1.4	3.3	3.3	1.4	7.6	3.3	1.4
Min over travel	mm	0.8	0.8	0.8	0.6	2.2	0.8	0.6
Tripping position OP	mm	14.4±0.4	21.8±1.2	18.9±1.2	20±0.6	15.2±1.2	15.2±1.2	15.1±0.5

GENERAL CHARACTERISTICS

■ Comply with		IEC/EN61058, UL1054
■ Rated insulation voltage U_i	V	250V
■ Rated impulse withstand voltage U_{imp}	V	1500
■ Rated thermal current I_{th}	A	8
■ Rated operating current I_e :	ac	8A - 250V resistive load, 3A - 250V inductive load
■ Ambient temperature	°C	-25 +85
■ Electric shock protection		Class II
■ Pollution class		2
■ Life	cycles	Mechanical 10^6 , electrical 5×10^5
■ Termination type		6.3x0.8 faston terminal

Foot switches

IP Series

Table of contents



TECHNO-CONTROL EQUIPMENT

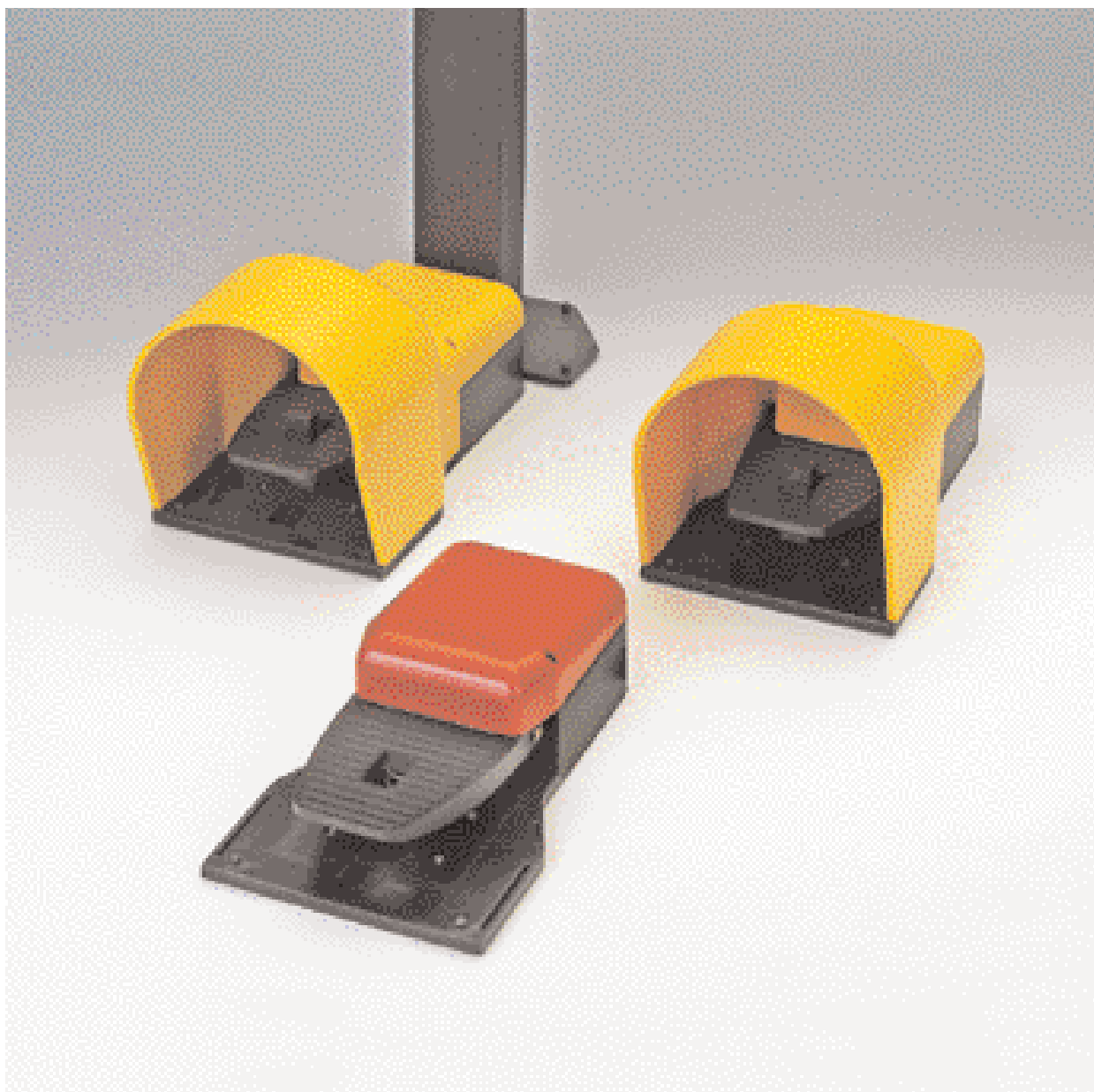

Single or double foot switches with the EN418 emergency stop option.
Available with electric or pneumatic controls.

TABLE OF CONTENTS

■ Single foot switches	pag. 98	■ Double foot switches – Technical data	pag. 99
------------------------	---------	---	---------

Foot switches

IP Series

IP54 □ thermoplastic type – Single

SAFETY FOOT SWITCHES

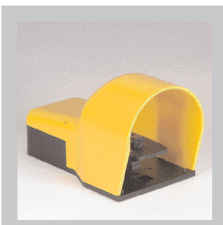
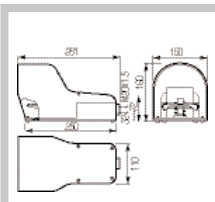
	DESCRIPTION	CONTACTS	REFERENCE NO.	WEIGHT gr.	MIN. PACK QTY.	DIMENSIONS
	With trigger mechanism requiring positive action to allow pedal operation	Slow break 1NO	IP7007	1.400	1	
		2NO	IP7008			

FOOT SWITCHES

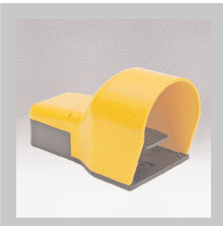
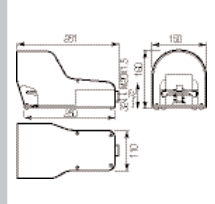
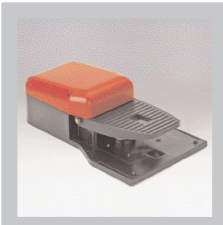
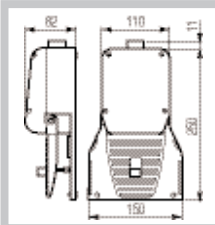
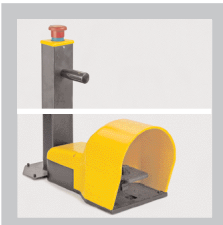
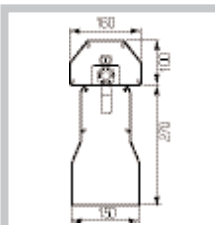
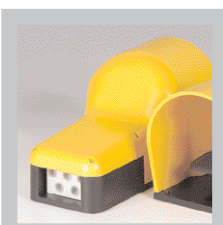
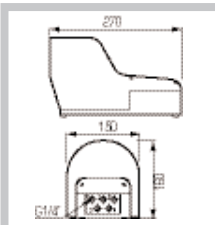
	DESCRIPTION	CONTACTS	REFERENCE NO.	WEIGHT gr.	MIN. PACK QTY.	DIMENSIONS
	With pedal latching device and without trigger mechanism	Slow break 1NO	IP 7011	1.400	1	
	Without rest position trigger mechanism	Slow break 1NC+1NO	IP7006I	1.300	1	
	With trigger mechanism and EN418 emergency stop	Slow break 1NO	IP7007EM	3.900	1	
	Pneumatic with trigger mechanism	With 1/4" 5 ways valve	IP7023	1.600	1	
	Pneumatic with pedal latching device and without trigger mechanism		IP7024		1	

Foot switches

IP Series

IP54 □ thermoplastic type – Double



TECHNO-CONTROL EQUIPMENT

DOUBLE

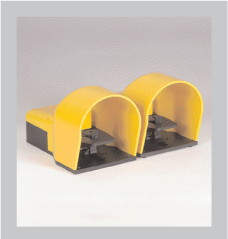
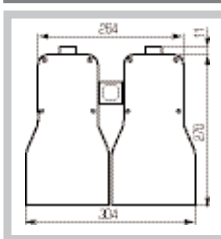
DESCRIPTION	CONTACTS	REFERENCE NO.	WEIGHT gr.	MIN. PACK QTY.	DIMENSIONS
 <p>With trigger mechanism requiring positive action to allow pedal operation</p>	Slow break		3.100	1	
	1NO	IP7018			
	2NO	IP7019			

DOUBLE WITH EN418 EMERGENCY STOP

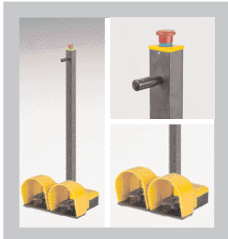
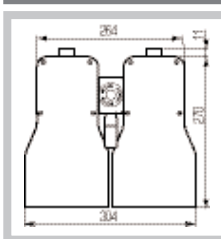
DESCRIPTION	CONTACTS	REFERENCE NO.	WEIGHT gr.	MIN. PACK QTY.	DIMENSIONS
 <p>With trigger mechanism requiring positive action to allow pedal operation</p>	Slow break		5.300	1	
	1NO	IP7018EM			
	2NO	IP7019EM			

GENERAL CHARACTERISTICS

Comply with		IEC/EN60947-5-1
Rated insulation voltage U_i	V	690 (pollution class 3)
Rated impulse withstand voltage U_{imp}	kV	4
Operating frequency	Hz	50/60
Rated thermal current I_{th}	A	10
Rated operating current I_e :		
AC-15 alterante current	V	24 60 110 230 400
	A	16 12 8 6 4,5
DC-13 continuous current	V	24 48 60 110 230
	A	2 1,2 0,85 0,4 0,25
Conditional short circuit withstand		1000A - 10A-500V class gG fuses
Contact impedance	mΩ	≤25
Contact type		Slow break double gap contacts
Positive opening		NC contact with positive opening 
Electric shock protection		Class II
Protection rating		IP54
Ambient temperature	°C	Operating -25 +70
	°C	Storage -30 +70
Termination type		Screw clamp terminals
Cable entry		No. 1 M20x1.5

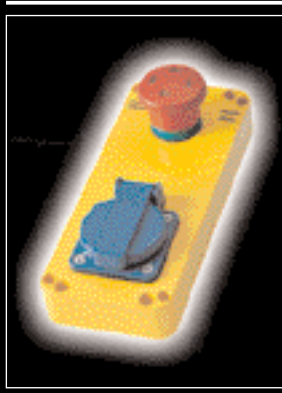
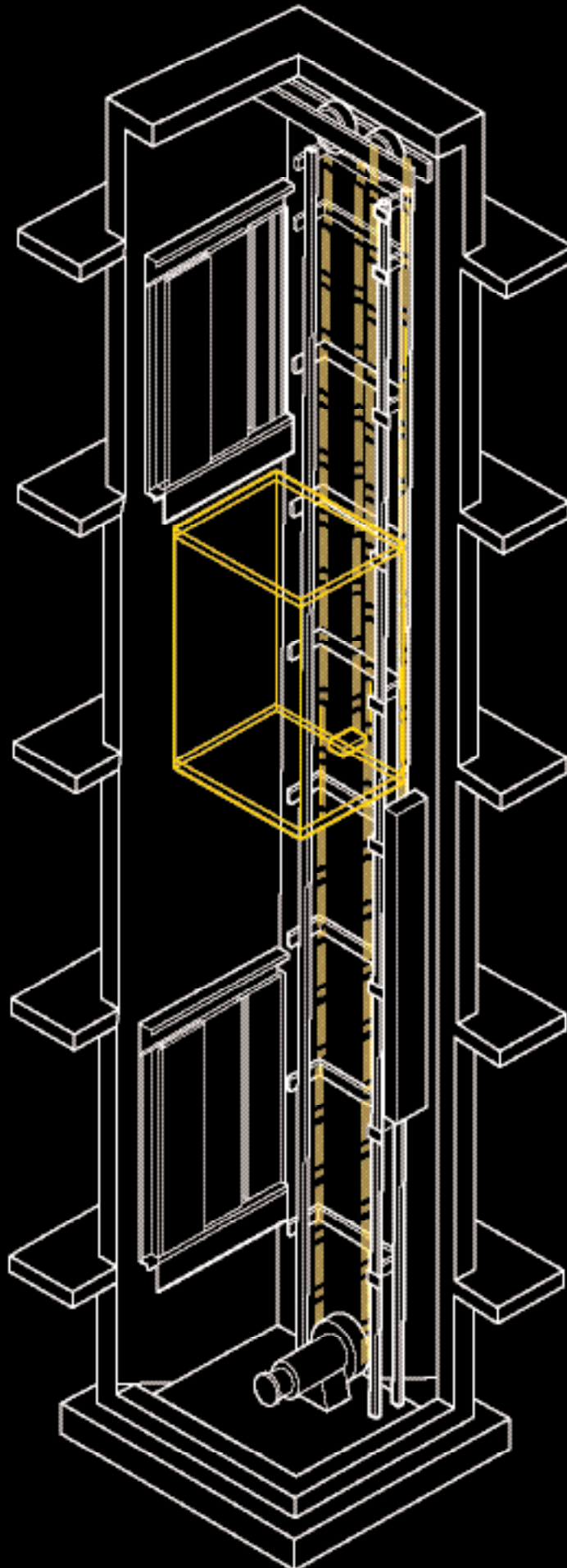

Lift

Pit bottom push button stations, recall drive control units and EN81 inspection boxes
Table of contents



TECHNO-CONTROL EQUIPMENT



Pit bottom switches with knob or interlocked lever, recall drive units with socket outlets, inspection boxes from 4 up to 8 functions.

Fully compliant with EN81..EN60068-2-6 - Resistance to vibrations - EN60068-2-27 Resistance to shocks. All components of the GM series are designed to the relevant standards, hence ensuring the correct creepage and clearance distances after possible vibrations and shocks.

TABLE OF CONTENTS

■ Pit bottom and recall drive control unit switches - Inspection boxes - Technical data	pag. 104	■ Recall drive push button stations	pag. 106
■ Pit bottom and recall drive control unit switches	pag. 105	■ Inspection boxes	pag. 107
		■ Accessories	pag. 110

Lift

Pit bottom push button stations, recall drive control units and EN81 Inspection boxes □ - Characteristics

ELECTRICAL CHARACTERISTICS

Giovenzana International B.V. is the market leader in the elevator market for electrical control accessories dedicated to maintenance. The different installations follow the guidelines set by the CEE95/16 directive and are designed for maximum safety. All articles are designed in compliance with the relevant product standard (IEC/EN 60947-3, IEC/EN 60947-5-1) and destination of use (EN 418 and IEC/EN 60204-1). The Lift series includes three product families that are commonly used in this field: pit bottom, recall drive push button stations, inspection boxes. On top of the standard range, made to order solutions are available complete with connectors.

- Comply with EN 418 and IEC/EN 60204-1
- Enclosures made of self extinguishing thermoplastic material. Double insulation
- Protection rating: IEC/EN60529 IP65 (IP54 whit socket outlet)
- Ambient temperature: Operating -25 °C +70 °C - Storage -30 °C +70 °C
- **Spring loaded terminal contact blocks**
- Vibration resistance IEC/EN60068-2-6 25g (10...500 Hz)

ELECTRICAL CHARACTERISTICS





		CONTACT BLOCKS		SWITCHES					
		IEC/EN60947-5-1 UL508		IEC/EN60947-3 UL508					
Comply with		IEC/EN60947-5-1 UL508		IEC/EN60947-3 UL508					
Certifications		IMQ, CCC, GOST, UL							
Rated insulation voltage U_i	V	690		690					
Rated impulse withstand voltage U_{imp}	kV	4		4					
Rated thermal current I_{th}	A	16		16					
Frequency	Hz	50/60		50/60					
Rated operating current I_e : AC-15 alterante current	V	24	60	110	230	400	500	690	-
	A	16	12	5	5	4	4	4	-
AC-21A alterante current	A	-		16					
AC-22A alterante current	A	-		16					
Conditional short circuit withstand	A	1000		5000					
Class gG fuses	A	10A - 500V		20A - 690V					
Contact type		Slow break double gap contacts							
Positive operation		NC contact with positive opening 		Suitable for sectioning					
Terminal type		Spring loaded		M3.5					
Terminal capacity:	Solid and flexible cable n. 1 min/max mm ²	0,5/2,5		0.75/4					
	n. 2 min/max mm ²	0,5/2,5		0.75/2.5					
	AWG	20-12		16-12					

Lift

Pit bottom and recall drive control unit switches IP54

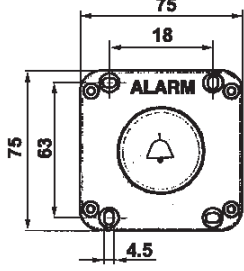

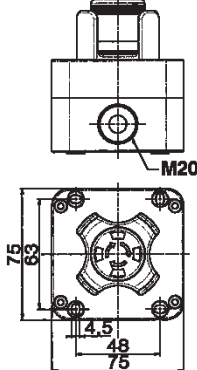
TECHNO-CONTROL EQUIPMENT

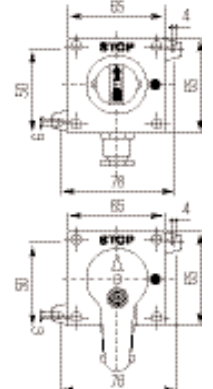
	DESCRIPTION	REFERENCE NO.	WEIGHT gr.	DIMENSIONS
	<p>Alarm push button station CE 95/16</p> <hr/> <p>Mushroom operator \varnothing 40</p>	<p>GM01FN3</p>	<p>150</p>	
	<p>Emergency stop push button  station EN418</p> <hr/> <p>Guarded mushroom operator \varnothing 40 push-pull with vision</p>	<p>GM01P4SP</p>	<p>150</p>	
	<p>Pit bottom switch</p> <hr/> <p>1P knob operated switch</p> <hr/> <p>1P lever operated switch with interlock in the Stop position</p> <hr/> <p>2P knob operated switch</p> <hr/> <p>Ui 440 - lthe 16A AC - 21A le 16A - 400V</p>	<p>GM353</p> <hr/> <p>GM354</p> <hr/> <p>GM355</p>	<p>90</p> <hr/> <p>110</p> <hr/> <p>95</p>	

Lift

Recall drive push button stations

IP54 □



DESCRIPTION

**Emergency stop ø 40
push-pull EN418** 
with:

No. 1 10A Schuko socket outlet

No. 1 CENELEC socket outlet

No. 1 American socket outlet

Contacts: Emergency 1NC

REFERENCE NO.

Mushroom with vision	Ergonomic mushroom
----------------------------	-----------------------

GM400	GM400.E
-------	---------

GM407	GM407.E
-------	---------

GM408	GM408.E
-------	---------

WEIGHT gr.

265

265

265

DIMENSIONS

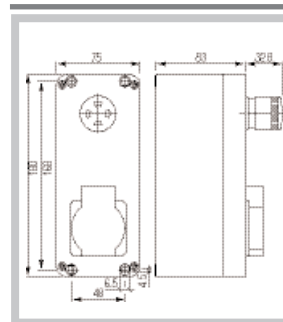

**3P 16A-690V
0-1 switch:**

No. 1 10A Schuko socket outlet

No. 1 CENELEC socket outlet

GM410

220

GM411

220

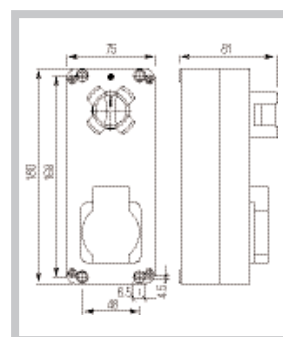

**Emergency stop ø 40
push-pull EN418** 
with:

No. 1 alarm push button

No. 1 10A Schuko socket outlet

No. 1 knob selector 0/1 90° op. angle

No. 1 10A Schuko socket outlet

Contacts:

Emergency 1NC

Push button 1NO

Selector 1NO

GM401

420

GM403

420

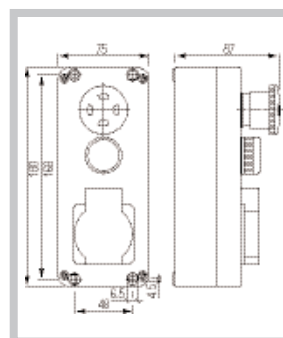

**Emergency stop ø 40
push-pull EN418** 
+ No. 1 multi-function
alarm-light push button
with:

No. 1 10A Schuko socket outlet

No. 1 CENELEC socket outlet

Contacts:

Emergency 1NC

Push button 1NO

Selector 1NO

GM491

450

GM492

450

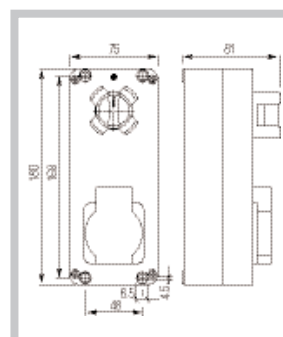









Lift

Inspection push button stations

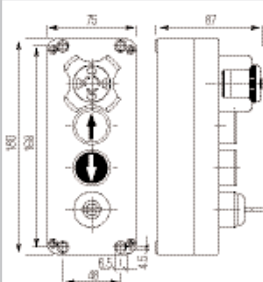
IP54 □

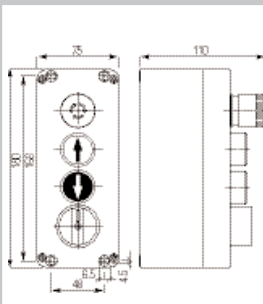

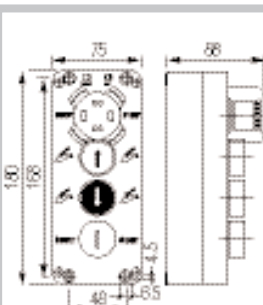

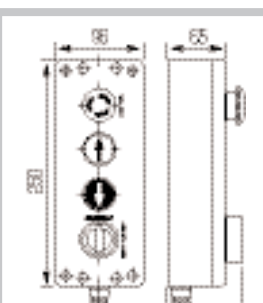





TECHNO-CONTROL EQUIPMENT

Image	DESCRIPTION	REFERENCE NO.	WEIGHT gr.	DIMENSIONS
	<p>Emergency stop ø 30 twist to release EN418 </p> <p>with:</p> <p>No. 1 UP push button</p> <p>No. 1 DOWN push button</p> <p>No. 1 key selector</p> <p>Contacts: Emergency 1NC Push buttons UP 2NO - DOWN 2NO Selector 1NO</p>	<p>GM420</p>	<p>690</p>	
	<p>Emergency stop ø 30 twist to release EN418 </p> <p>with:</p> <p>No. 1 UP push button</p> <p>No. 1 DOWN push button</p> <p>No. 1 changeover switch 1-0-2</p> <p>Contacts: Emergency 1NC Push buttons UP 2NO - DOWN 2NO Changeover switch 2NO+2NC</p>	<p>GM488</p>	<p>680</p>	
	<p>Emergency stop ø 40 twist to release EN418 </p> <p>with:</p> <p>No. 1 UP push button</p> <p>No. 1 DOWN push button</p> <p>No. 1 START push button</p> <p>Contacts: Emergency 1NC Push button UP 1NC+1NO Push button DOWN 1NC+1NO Push button START 1NO</p>	<p>GM482</p>	<p>690</p>	
	<p>Emergency stop ø 40 twist to release EN418 </p> <p>+ No. 1 UP push button + No. 1 DOWN push button with:</p> <p>No. 1 changeover switch 1-0-2</p> <p>No. 1 changeover switch 1-2</p> <p>Contacts: Emergency 1NC Push button UP 2NO Push button DOWN 2NO Changeover switch 2NO+2NC</p>	<p>GM442 GM444</p>	<p>635 635</p>	

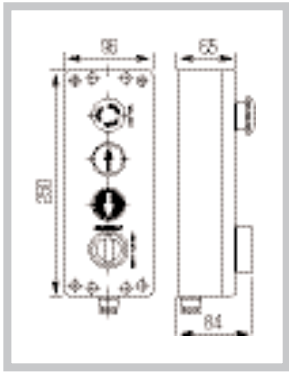
Lift

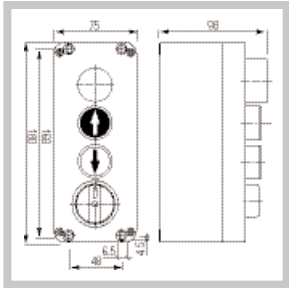
Inspection push button stations

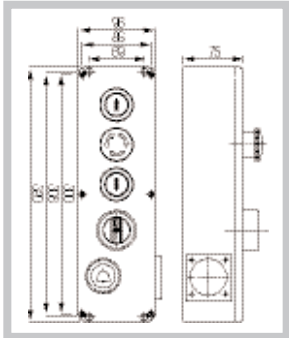
IP54 □

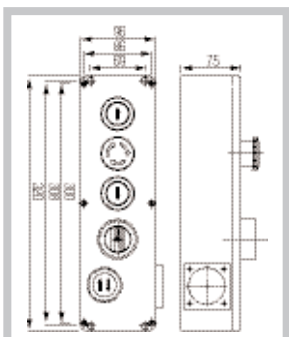
	DESCRIPTION	REFERENCE NO.	WEIGHT gr.	DIMENSIONS
	Emergency stop σ 40 twist to release EN418  + No. 1 UP push button + No. 1 DOWN push button with:	GM441 GM445	680 680	
	No. 1 changeover switch 1-2 No. 1 10A Schuko socket outlet (side mounted) No. 1 changeover switch 1-0-2 No. 1 10A Schuko socket outlet (side mounted)			
	Contacts: Emergency 1NC Push buttons UP 2NO - DOWN 2NO Changeover switch 2NO+2NC			
	LED pilot light with:	GM483	600	
	No. 1 UP push button No. 1 DOWN push button No. 1 changeover switch 1-2			
	Contacts: Push buttons UP 1NO - DOWN 1NO Changeover switch 2NO+2NC			
	Emergency stop σ 40 twist to release EN418  + No. 1 UP push button + No. 1 DOWN push button + No. 1 alarm push button + No. 1 10A Schuko socket outlet (side mounted) with:	GM660 GM670	800 800	
	No. 1 changeover switch 1-2 No. 1 changeover switch 1-0-2			
	Contacts: Emergency 2NC Push buttons UP 2NO - DOWN 2NO Alarm push button 1NO+1NC, Changeover switch 3NO+3NC			
	Emergency stop σ 40 twist to release EN418  + No. 1 UP push button + No. 1 DOWN push button + No. 1 common push button + No. 1 10A Schuko socket outlet (side mounted) with:	GM663 GM677	800 800	
	No. 1 changeover switch 1-2 No. 1 changeover switch 1-0-2			
	Contacts: Emergency 2NC Push buttons UP 2NO - DOWN 2NO Common push button 2NO, Changeover switch 3NO+3NC			



Lift

Inspection push button stations

IP54 □

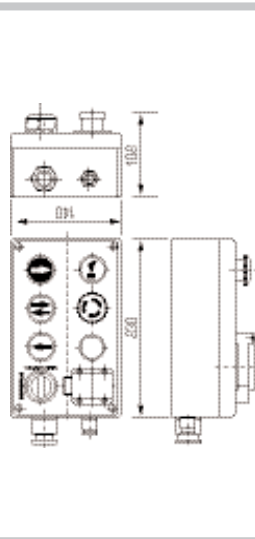

TECHNO-CONTROL EQUIPMENT

	DESCRIPTION	REFERENCE NO.	WEIGHT gr.	DIMENSIONS
	<p>Emergency stop ø 40 twist to release EN418 </p> <p>with:</p> <ul style="list-style-type: none"> No. 1 UP push button No. 1 DOWN push button No. 1 alarm push button No. 1 common push button No. 1 changeover switch 1-2 No. 1 10A Schuko socket outlet <p>Contacts: Emergency 2NC Push buttons UP - DOWN 2NO+1NC Alarm push button 1NO Common push button 2NO Changeover switch 3NO+3NC</p>	<p>GM412</p>	<p>950</p>	

	
---	--

DESCRIPTION	REFERENCE NO.	WEIGHT gr.
<p>Emergency stop ø 30 twist to release EN418 </p> <p>with:</p> <ul style="list-style-type: none"> No. 1 UP push button No. 1 DOWN push button No. 1 alarm push button No. 1 common push button No. 1 LED pilot light No. 1 changeover switch 1-2 No. 1 10A Schuko socket outlet <p>Contacts: Emergency 1NC Push buttons UP - DOWN 2NO+1NC Alarm push button 1NO - Common push button 2NO Changeover switch 3NO+3NC</p>	<p>GM822</p>	<p>965</p>

Lift

Pit bottom push button stations, recall drive control units and inspection boxes
Accessories

AMERICAN SOCKET OUTLET



20401369

EUROPEAN SOCKET OUTLET



20401371

FRENCH SOCKET OUTLET



20401372

BRITISH STANDARD SOCKET OUTLET



20401398

SWISS SOCKET OUTLET



20401399

CONTACT BLOCKS

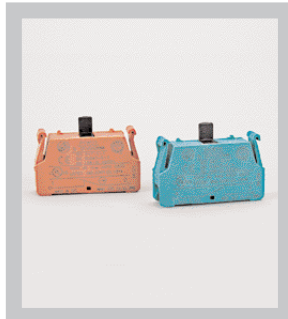

Spring loaded terminals

1NC	PCW01
1NO	PCW10

BAGs LAMP HOLDER

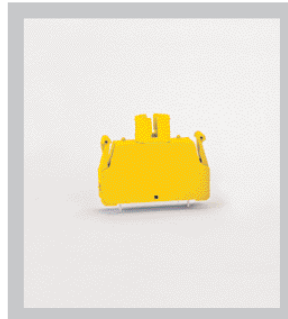

Direct power supply with spring loaded terminals

PCWAD

EMERGENCY STOP GUARD



11706006



SPECIALS

It is possible to supply custom made assemblies according to the specifications required by the customer:

- Custom made push buttons and controls
- Pre-cabled
- With or without connectors
- With dedicated brackets

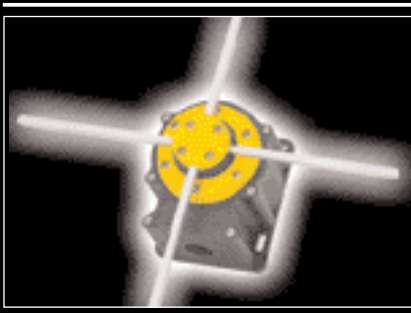
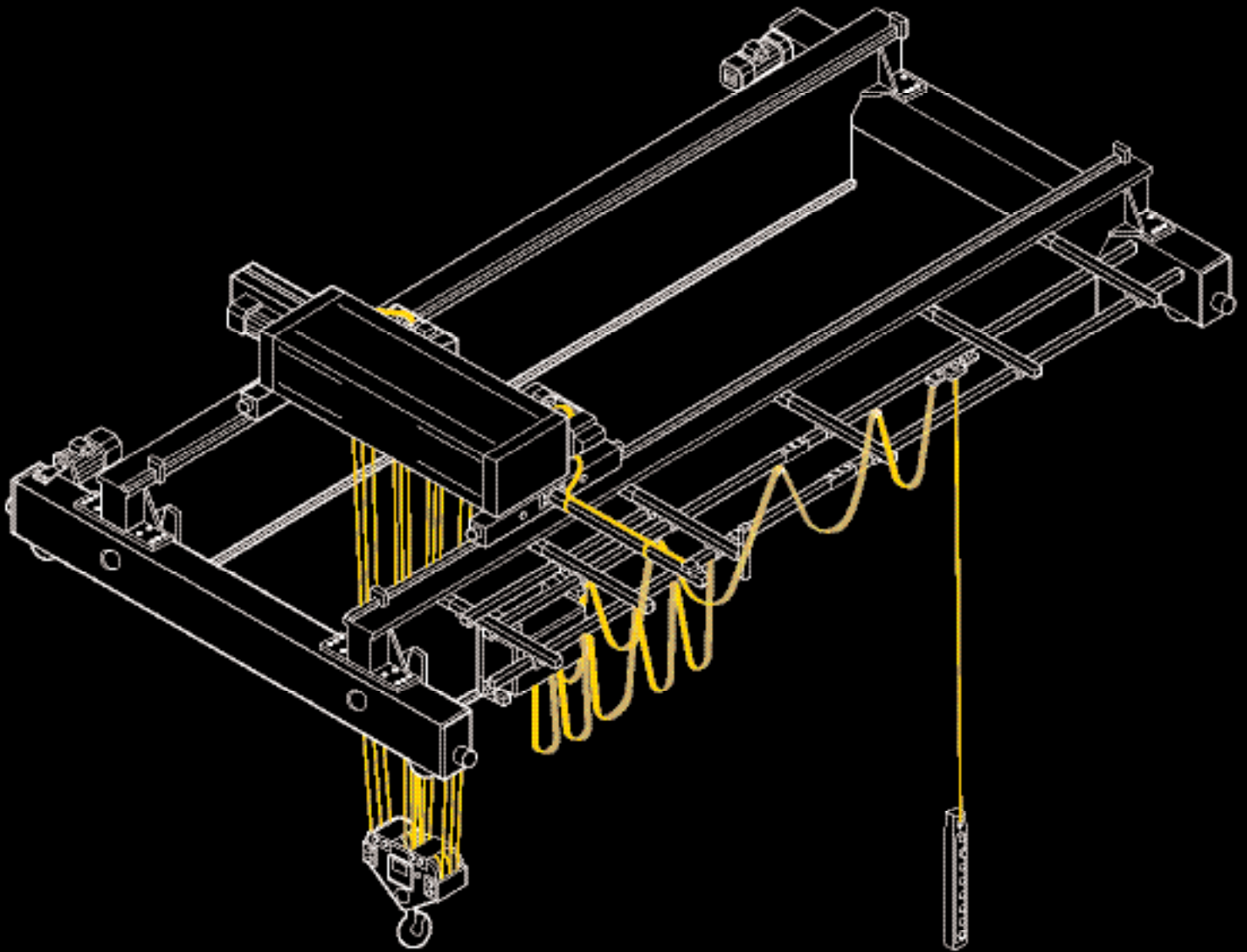
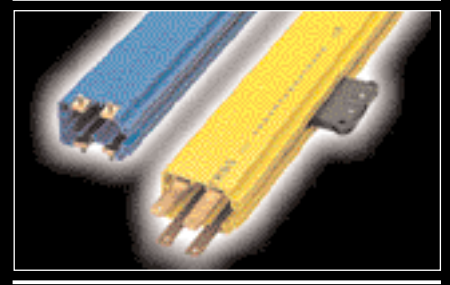
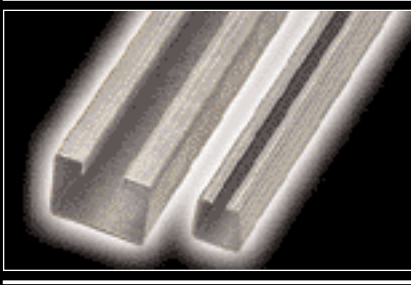

Pendant stations

P02 - PTRM - P03 - DC16 - PL - DC30 - TLP Series

Table of contents



TECHNO-CONTROL EQUIPMENT



Push button stations for small hoist applications, for control circuits in both single or double row versions, for control and direct switching power circuits, for tail lifts control.

TABLE OF CONTENTS

■ General characteristics	pag. 114	■ Accessories	pag. 121
■ P02-PTRM series pendant stations for small hoist applications	pag. 115	■ PL series pendant stations for control circuits – Composition	pag. 122
■ P03 series pendant stations for small hoist applications	pag. 116	■ PL series pendant stations for control circuits – Engravings	pag. 123
■ DC16 series pendant stations for small hoist applications	pag. 117	■ PL series pendant stations for control circuits – Assembly	pag. 124
■ Single row PL series pendant stations for control circuits	pag. 118	■ DC30 series pendant stations for direct switching power circuits	pag. 126
■ Double row PL series pendant stations for control circuits	pag. 119	■ DC30 series accessories	pag. 128
■ PL series pendant station enclosures for control circuits	pag. 120	■ TLP series push button stations for tail lifts	pag. 129
		■ Characteristics	pag. 131

Pendant stations

P02 - PTRM - P03 - DC16 - PL - DC30 - TLP Series

General characteristics

According to the CE89/392 directives appendix IIB concerning machinery

GIOVENZANA

declares that P02 - P03 - PL - PLB pendant stations comply with the following standards:

Harmonised standards

EN292 part 1 and 2 (machine safety)
UNI EN ISO 9001
EN60529 (IP rating)

Standards and technical specifications

IEC 947-5-1 (low voltage equipment)
FEM 9.941 (operators' designation)

As stated in appendix V of the CE directives with regards to machinery

The technical documentation is held by the manufacturer.

The company Giovenzana, leader in lifting equipment control accessories, has designed the P02 - P03 - PL - PLB series pendant stations according to the relevant International standards

These new product series are the end result of a close investigation with regards to the operator's needs and requirements:

- Adequate cabling space
- Ease of use thanks to a light and user friendly pendant station
- Versatility of assembly allowing quick and easy replacement of the 22 Ø operators and their Pegasus contact blocks
- Each pendant station is provided with a new generation EN418 emergency stop incorporating a snap action actuation that prevents halting the machinery before the mushroom is in the locked position. Contacts are "positive opening" type.
- The following contacts are supplied as standard:
1NO for the movement (FEM 9.941)
1NC for emergency (EN418)
1NO+1NO for double speed
Optional accessories are always supplied separately and installed by the end user.

GENERAL CHARACTERISTICS

- Double insulated enclosures in thermoplastic self-extinguishing material
- IP65 rating according to EN60529
- Operating temperature -25 +70 °C
- Available from 2 up to 14 holes - 22 Ø - on single or double row
- Cable entry: P02 - PTRM - P03 - PL with variable section cable sleeve
DC16 - DC30 - TLP with cable clamp
- Mechanical life: push buttons and rotary switches
- 1 mil. operations
Latched emergency stops
- 0,3 mil. operations

CONTACT BLOCK CHARACTERISTICS

- VO UL94 self-extinguishing material
- Rated thermal current: 16A
- Rated insulation voltage: 690V
- Insulation category: Group CV VDE 0110
- Contact impedance: ≤25 MΩ
- Slow break self cleaning double gap contact block - Positive opening NC contact block
- Tripping force: 4N
- Terminal protection rating: IP20 - EN60529
- Max contact No.: 3
- **UL A600 - Q 600** certified















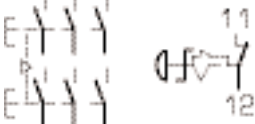
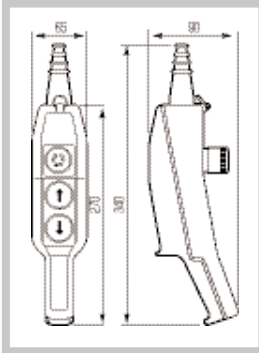





Pendant stations

P03 Series for small hoist applications

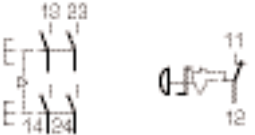
IP65 □

P03

2 directions mechanically interlocked

	ENGRAVING	DESCRIPTION	REFERENCE NO.	WEIGHT gr	DIMENSIONS	
	  	<p>For single-speed motor control</p> <p>No. 1 Emergency stop ø 30 turn to release EN418 with:</p> <p>No. 2 push buttons with 1 NO contact No. 2 push buttons with 2 NO contacts No. 2 push buttons with 3 NO contacts</p> 	<p>P03.1</p> <p>P03.2</p> <p>P03.3</p>	<p>440</p> <p>450</p> <p>460</p>		
		  	<p>For 1kW single-phase motor control</p> <p>No. 1 Emergency stop ø 30 turn to release EN418 with:</p> <p>No. 2 push buttons with 1NC+2NO contacts</p> 	<p>P03CD</p>		<p>460</p>
			  	<p>For two-speed motor control</p> <p>No. 1 Emergency stop ø 30 turn to release EN418 with:</p> <p>No. 2 push buttons with 1NC+2NO contacts</p> 		<p>P03D2</p>
	  		<p>For single-speed motor control</p> <p>No. 1 90° angle latched key switch O-1 with 1 NO contact and:</p> <p>No. 2 push buttons with 1 NO contact</p> 	<p>P03CH</p>	<p>460</p>	

Pendant stations

DC16 Series for small hoist applications

IP65 □



TECHNO-CONTROL EQUIPMENT

GENERAL CHARACTERISTICS

- Double insulated ABS enclosures
- IP65 protection rating according to IEC/EN 60529
- Ambient temperature: operating $-25^{\circ} +70^{\circ} \text{ }^{\circ}\text{C}$
storage $-40^{\circ} +70^{\circ} \text{ }^{\circ}\text{C}$
- Double gap slow break contacts
- Cable entry with M25 cable clamp
- Rated insulation voltage: U_i 690V
- Rated thermal current Ith: 16A
- Rated operating power: 400V ac -1kW

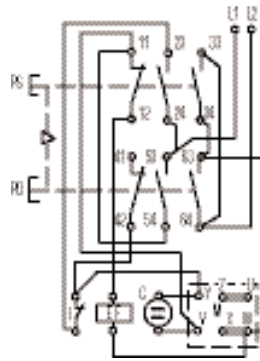

1KW DIRECT SWITCHING MOTOR WIRING DIAGRAM

PS UP push button

PD DOWN push button

I Top limit switch

M Motor

C Capacitor

EF Electric break

2 directions mechanically interlocked

ENGRAVING

DESCRIPTION

REFERENCE NO.

WEIGHT gr

DIMENSIONS



For 1kW single-phase motor control
No. 1 Emergency stop
 \varnothing 30 turn to release
EN418 with 2NC+1NO contacts and:
No. 2 push buttons with 1NC+2NO contacts



DC16

470



For 1kW single-phase motor control
No. 1 Emergency stop
 \varnothing 30 turn to release
EN418 with 2NC contacts and:
No. 2 push buttons with 1NC+2NO contacts

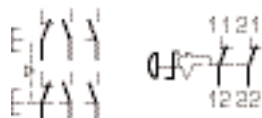

DC16I



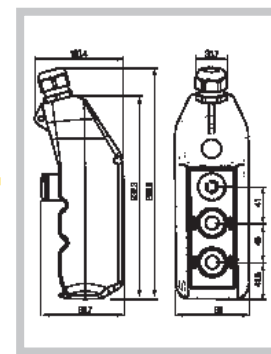

490



Pendant stations

PL Series for control circuits

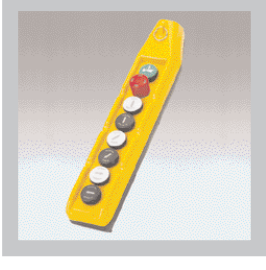
IP65 □ Single row

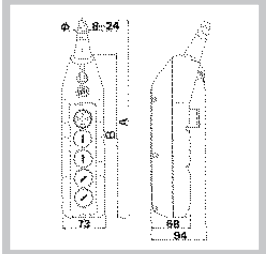
	PUSH BUTTONS	DESCRIPTION	REFERENCE NO.	WEIGHT gr	
	4+1	For single-speed motor control 4 mechanically interlocked between pairs + 1 Emergency stop ø 30 turn to release EN418	PL05	560	
	4+1	For two-speed motor control ▶▶ 4 mechanically interlocked between pairs + 1 Emergency stop ø 30 turn to release EN418			
			No. of 2-speed movements		
			2	PL05D2	590
			4	PL05D4	620
	6+1	For single-speed motor control 6 mechanically interlocked + 1 Emergency stop ø 30 turn to release EN418	PL07	740	
	6+1	For two-speed motor control ▶▶ 6 mechanically interlocked between pairs + 1 Emergency stop ø 30 turn to release EN418			
			No. of 2-speed movements		
			2	PL07D2	770
			4	PL07D4	800
			6	PL07D6	830
	6+2	For single-speed motor control 6 mechanically interlocked between pairs + 1 Start/Alarm + 1 Emergency stop ø 30 turn to release EN418	PL08	830	
	6+2	▶▶ 6 mechanically interlocked between pairs + 1 Start/Alarm + 1 Emergency stop ø 30 turn to release EN418			
			No. of 2-speed movements		
			2	PL08D2	860
			4	PL08D4	890
			6	PL08D6	920
	8+2	For single-speed motor control 8 mechanically interlocked between pairs + 1 Start/Alarm + 1 Emergency stop ø 30 turn to release EN418	PL10	990	
	10+2	For single-speed motor control 10 mechanically interlocked between pairs + 1 Start/Alarm + 1 Emergency stop ø 30 turn to release EN418	PL12	1.140	
	DIMENSIONS				
	PUSH BUTTONS	REFERENCE NO.	Amm	Bmm	
	5	PL05	345	288	
	7	PL07	495	358	
	8	PL08	530	393	
	10	PL10	640	463	
12	PL12	710	533		
				For the push button designation and symbols please see page 123 Colour:	
				□ Black and white	
				■ Start/Alarm green	
				■ Emergency red	





Pendant stations

PL Series for control circuits

IP65 □ Double row

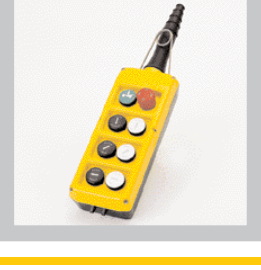

TECHNO-CONTROL EQUIPMENT

	PUSH BUTTONS	DESCRIPTION	REFERENCE NO.	WEIGHT gr	
	2+2	For single-speed motor control 2 mechanically interlocked + 1 Start/Alarm + 1 Emergency stop ø 30 turn to release EN418	PLB04	560	
	2+2	For two-speed motor control 2 mechanically interlocked + 1 Start/Alarm + 1 Emergency stop ø 30 turn to release EN418	PLB04D2	590	
	4+2	For single-speed motor control 4 mechanically interlocked between pairs + 1 Start/Alarm + 1 Emergency stop ø 30 turn to release EN418	PLB06	560	
	4+2	For two-speed motor control 4 mechanically interlocked between pairs + 1 Start/Alarm + 1 Emergency stop ø 30 turn to release EN418	PLB06D2	690	
			PLB06D4	720	
	6+2	For single-speed motor control 6 mechanically interlocked between pairs + 1 Start/Alarm + 1 Emergency stop ø 30 turn to release EN418	PLB08	840	
	6+2	For two-speed motor control 6 mechanically interlocked between pairs + 1 Start/Alarm + 1 Emergency stop ø 30 turn to release EN418	PLB08D2	870	
			PLB08D4	900	
			PLB08D6	1.030	
	8+2	For single-speed motor control No of operators mechanically interlocked + 1 Start/Alarm + 1 Emergency stop ø 30 turn to release EN418	PLB10	1.150	
	10+2				10
	12+2				12

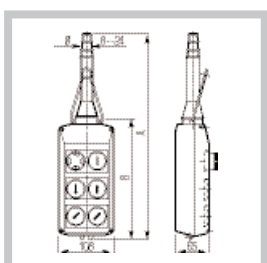

DIMENSIONS

PUSH BUTTONS	REFERENCE NO.	Amm	Bmm
4	PLB04	345	185
6	PLB06	399	239
8	PLB08	453	293
10	PLB10	547	347
12	PLB12	601	401
14	PLB14	655	455

For the push button designation and symbols please see page 123
Colour:

■ Black and white

■ Start/Alarm green

■ Emergency red

Pendant stations

PL series for control circuits

IP65 □ Enclosures

SINGLE ROW



NO OF HOLES	CABLE ENTRY Ø	REFERENCE NO.	WEIGHT gr	MIN. PACK QTY.
5	7...18	PL05K	410	1
7	9...21	PL07K	540	1
8		PL08K	600	1
10		PL10K	700	1
12		PL12K	800	1

DOUBLE ROW



NO OF HOLES	CABLE ENTRY Ø	REFERENCE NO.	WEIGHT gr	MIN. PACK QTY.
4	9...21	PLB04K	410	1
6		PLB06K	510	1
8		PLB08K	610	1
10	12...24	PLB10K	710	1
12		PLB12K	810	1
14		PLB14K	910	1

Enclosures are supplied with accessories with the exception of contact blocks and operators which must be purchased separately. Refer to page 121 for more information. For assembly instructions see page 124-125.

Pendant stations

For control and direct switching power circuits
Accessories



TECHNO-CONTROL EQUIPMENT

CONTACT BLOCKS



1 NC	PL004001
1 NO	PL004002

MULTI-SPEED CONTACT BLOCKS

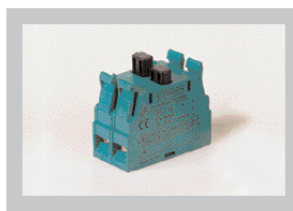

2-SPEED	PL004010
1NO+1NO PROGRESSIVE	

LAMP HOLDERS



BA9s	PL004007
------	----------

LENS CAP



1	2	PL00800
3	4 □ 5	

KEY SWITCH



0-1	PL006001
1-0-2	PL006002

ROTARY SWITCH



0-1	PL007001
1-0-2	PL007002

MUSHROOM OPERATOR Ø 30 TURN TO RELEASE EN418



WITH VISION	PL013001
STANDARD	PL013002

MUSHROOM OPERATOR Ø 40 EN418



PL013003

PUSH BUTTONS

COLOUR	REF. NO.
	PL005034
	PL005035
	PL005036
	PL005037
	PL005038
With engraving	PL0050...*

* See page 123



COUPLING PLATE

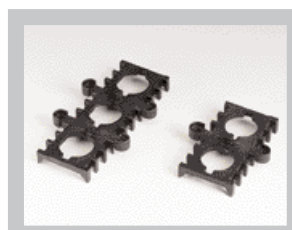

2 HOLES	PL003001
3 HOLES	PL003002

INTERLOCK

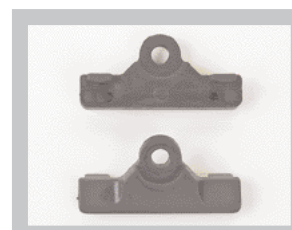

TOP	PL011001
BOTTOM	PL011002

CABLE CLAMP LEVER



PL012001

VERSIONS

P02 - PTRM
For 7...14 Ø cable

P03 - PL05
For 7...18 Ø cable

PL07...PL12
PLB04-PLB06
For 9...21 Ø cable

PLB08-PLB14
For 12...24 Ø cable

CABLE SLEEVE

REFERENCE NO.

12906011

12906006

12906004

12906005



Pendant stations

For control and direct switching power circuits

Composition

PL SERIES

STANDARD VERSIONS

PL05	PL0502	PL0504
STOP	STOP	STOP
LIFT UP	1/2 SPEED LIFT UP	1/2 SPEED LIFT UP
LIFT DOWN	1/2 SPEED LIFT DOWN	1/2 SPEED LIFT DOWN
HOIST RIGHT	HOIST RIGHT	1/2 SPEED HOIST RIGHT
HOIST LEFT	HOIST LEFT	1/2 SPEED HOIST LEFT

PL07	PL08	PL0802	PL0804	PL0806	PL10	PL12
STOP	START	START	START	START	START	START
LIFT UP	LIFT UP	LIFT UP	1-2 SPEED LIFT UP	1-2 SPEED LIFT UP	LIFT UP	LIFT UP
LIFT DOWN	LIFT DOWN	LIFT DOWN	1-2 SPEED LIFT DOWN	1-2 SPEED LIFT DOWN	LIFT DOWN	LIFT DOWN
D/H CRANE FORWARD	D/H CRANE FORWARD	D/H CRANE FORWARD	12 SPEED D/H CRANE FORWARD	12 SPEED D/H CRANE FORWARD	D/H CRANE FORWARD	LIFT UP FAST
D/H CRANE REVERSE	D/H CRANE REVERSE	D/H CRANE REVERSE	12 SPEED D/H CRANE REVERSE	12 SPEED D/H CRANE REVERSE	D/H CRANE REVERSE	LIFT DOWN FAST
HOIST RIGHT	HOIST RIGHT	HOIST RIGHT	HOIST RIGHT	1/2 SPEED HOIST RIGHT	D/H CRANE FORWARD FAST	D/H CRANE FORWARD
HOIST LEFT	HOIST LEFT	HOIST LEFT	HOIST LEFT	1/2 SPEED HOIST LEFT	D/H CRANE REVERSE FAST	D/H CRANE REVERSE

PLB SERIES

STANDARD VERSIONS

PLB04	PLB0402	PLB0604	PLB0602	PLB06D4	PLB08D4	PLB14	PLB10
START	STOP	START	STOP	START	STOP	START	STOP
LIFT UP	LIFT DOWN	1/2 SPEED LIFT UP	1/2 SPEED LIFT DOWN	1/2 SPEED LIFT UP	1/2 SPEED LIFT DOWN	UP FAST	DOWN FAST
START	STOP	START	STOP	12 SPEED LIFT UP	12 SPEED LIFT DOWN	LIFT UP	LIFT DOWN
LIFT UP	LIFT DOWN	LIFT UP	LIFT DOWN	12 SPEED D/H CRANE FORWARD	12 SPEED D/H CRANE REVERSE	D/H CRANE FORWARD	D/H CRANE REVERSE
D/H CRANE FORWARD	D/H CRANE REVERSE	12 SPEED D/H CRANE FORWARD	12 SPEED D/H CRANE REVERSE	HOIST LEFT	HOIST RIGHT	UP	DOWN
PLB08	PLB0802	PLB08D6	PLB12	PLB14	PLB10	START	STOP
START	STOP	START	STOP	START	STOP	ALARM	LIFT UP
LIFT UP	LIFT DOWN	LIFT UP	LIFT DOWN	UP FAST	DOWN FAST	LIFT UP	LIFT DOWN
D/H CRANE FORWARD	D/H CRANE REVERSE	12 SPEED D/H CRANE FORWARD	12 SPEED D/H CRANE REVERSE	D/H CRANE FORWARD	D/H CRANE REVERSE	D/H CRANE FORWARD	D/H CRANE REVERSE
HOIST LEFT	HOIST RIGHT	12 SPEED HOIST LEFT	12 SPEED HOIST RIGHT	HOIST LEFT	HOIST RIGHT	12 SPEED D/H CRANE FORWARD	12 SPEED D/H CRANE REVERSE
HOIST LEFT	HOIST RIGHT	12 SPEED HOIST LEFT	12 SPEED HOIST RIGHT	HOIST LEFT	HOIST RIGHT	HOIST LEFT	HOIST RIGHT

Pendant stations

For control and direct switching power circuits
Engravings



TECHNO-CONTROL EQUIPMENT

FEM 9.941 STANDARD

UP	DOWN	FORWARD	REVERSE	LEFT	RIGHT	SPIN LEFT	SPIN RIGHT	GREEN START	GREEN START ALARM
PLD05004	PLD05019	PLD05012	PLD05027	PLD05023	PLD05008	PLD05031	PLD05016	PLD05001	PLD05002
PLD05005	PLD05020	PLD05013	PLD05028	PLD05024	PLD05009	PLD05032	PLD05017	PLD05003	PLD05004
PLD05006	PLD05021	PLD05014	PLD05029	PLD05025	PLD05010	PLD05033	PLD05018	PLD05035	PLD05036
PLD05007	PLD05022	PLD05015	PLD05030	PLD05026	PLD05011			PLD05037	PLD05038

LASER ENGRAVING: Optional engravings can be made to order according to special customer specification (min. quantity applies)

Pendant stations

For control and direct switching power circuits

Assembly

PL SERIES STANDARD VERSIONS

PL single row pendant station

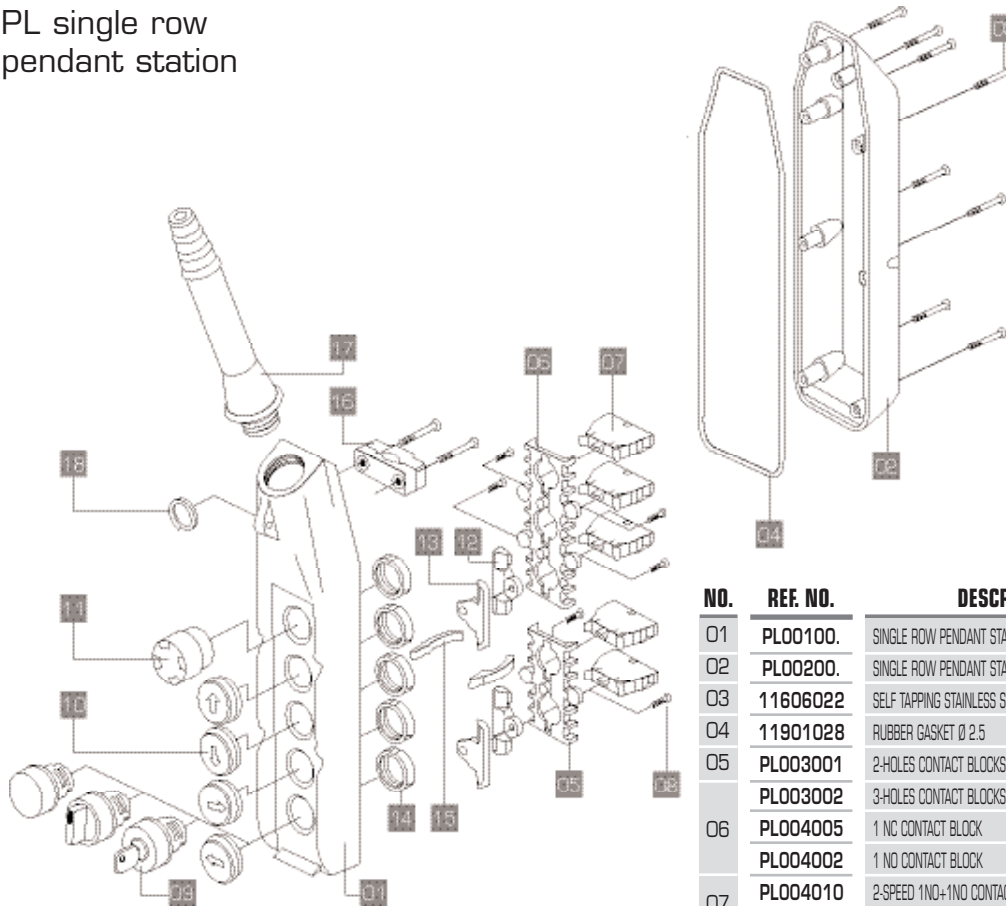

ASSEMBLY INSTRUCTION FOR 1-2-SPEED CONTACT BLOCKS

PL004010

PL004003 1-SPEED

PL004004 2-SPEED

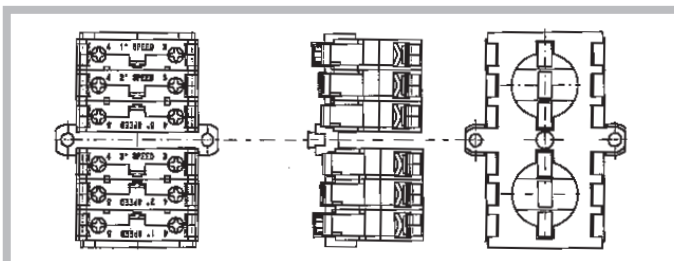

NO.	REF. NO.	DESCRIPTION	QTY.
01	PL00100.	SINGLE ROW PENDANT STATION COVER...PUSH BUTTONS	1
02	PL00200.	SINGLE ROW PENDANT STATION BASE...PUSH BUTTONS	1
03	11606022	SELF TAPPING STAINLESS STEEL SCREW 4X30	..
04	11901028	RUBBER GASKET Ø 2.5	MT..
05	PL003001	2-HOLES CONTACT BLOCKS SUPPORT	..
	PL003002	3-HOLES CONTACT BLOCKS SUPPORT	..
06	PL004005	1 NC CONTACT BLOCK	..
	PL004002	1 NO CONTACT BLOCK	..
07	PL004010	2-SPEED 1N0+1N0 CONTACT BLOCK	..
	PL004007	LAMP HOLDER	..
08	11607007	SELF TAPPING SCREW 3.9X13	..
	PL00700.	ROTARY SWITCH	..
09	PL00600.	KEY SWITCH	..
	PL00800.	PILOT LIGHT	..
10	PL0050..	ENGRAVED PUSH BUTTONS	..
11	PL013001	MUSHROOM OPERATOR TURN TO RELEASE WITH VISION	1
12	PL011002	BOTTOM MECHANICAL INTERLOCK	..
13	PL011001	TOP MECHANICAL INTERLOCK	..
14	11705100	M22 ZAMA LOCK NUTS	..
15	PL012001	CABLE CLAMP LEVER	..
	12904014	CABLE CLAMP	1
16	12906006	PL05 CABLE SLEEVE	..
	12906004	PL07 - PL08 CABLE SLEEVE	..
17	12906005	PL10 - PL12 CABLE SLEEVE	..
18	12003009	SUNSPENSION RING	1

Pendant stations

For control and direct switching power circuits
Assembly



TECHNO-CONTROL EQUIPMENT

PL SERIES STANDARD VERSIONS

PL double row
pendant station

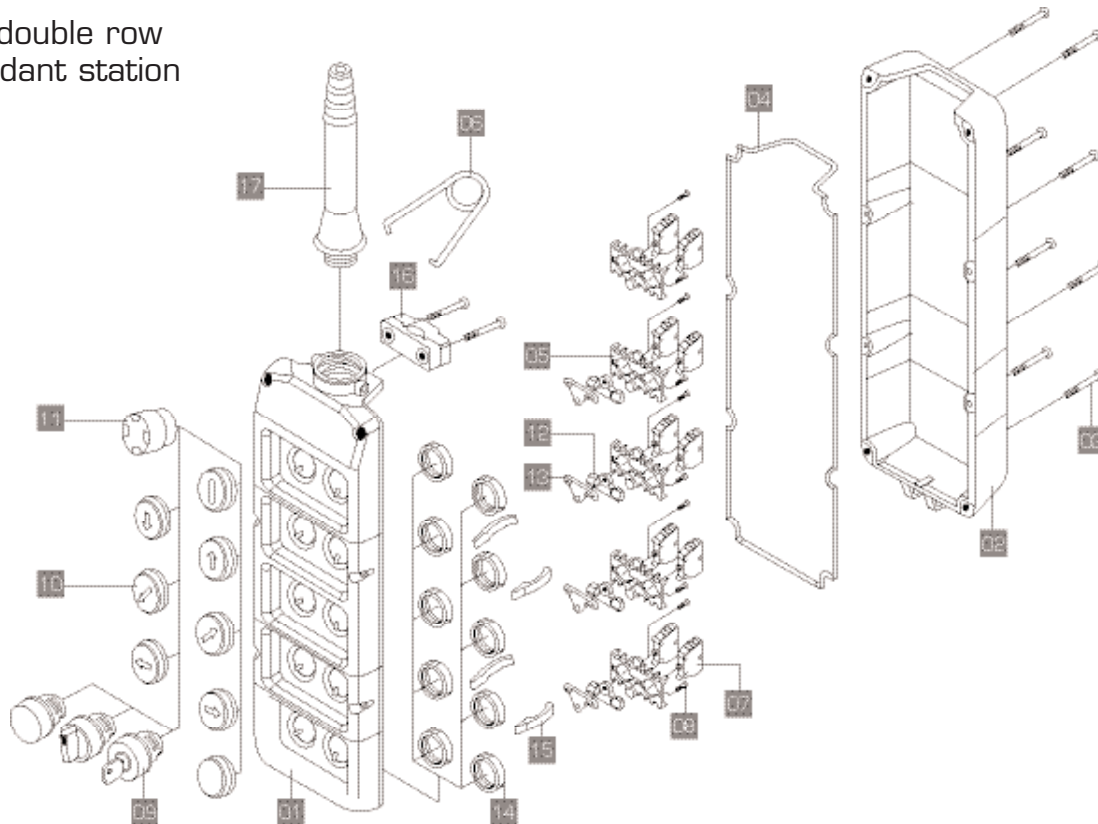

NO.	REF. NO.	DESCRIPTION	QTY.
01	1170807.	DOUBLE ROW PENDANT STATION COVER...PUSH BUTTONS	1
02	1171004.	DOUBLE ROW PENDANT STATION BASE...PUSH BUTTONS	1
03	11606022	SELF TAPPING STAINLESS STEEL SCREW 4X30	..
04	11901035	RUBBER GASKET Ø 2	MT..
05	PL003001	2-HOLE CONTACT BLOCKS SUPPORT	..
	12001021	SUNSPENSION RING	1
06	PL004001	1 NC CONTACT BLOCK	..
	PL004002	1 NO CONTACT BLOCK	..
07	PL004010	2-SPEED 1NO+1NO CONTACT BLOCK	..
	PL004007	LAMP HOLDER	..
	11607007	SELF TAPPING SCREW 3.9X13	..
08	PL00700..	ROTARY SWITCH	..
	PL00600..	KEY SWITCH	..
	PL00800..	PILOT LIGHT	..
09	PL0050...	ENGRAVED PUSH BUTTONS	..
10	PL013001	MUSHROOM OPERATOR TURN TO RELEASE WITH VISION	1
11	PL011002	BOTTOM MECHANICAL INTERLOCK	..
12	PL011001	TOP MECHANICAL INTERLOCK	..
13	11705100	M22 ZAMA LOCK NUTS	..
14	PL012001	CABLE CLAMP LEVER	..
15	12904008-09	CABLE CLAMP	1+1
16	12906004	PLB04 - 06 - 08 CABLE SLEEVE	..
17	12906005	PLB10 - 12 - 14 CABLE SLEEVE	..

Pendant stations

DC30 series pendant stations for power circuits









IP65 □ direct switching

GENERAL CHARACTERISTICS

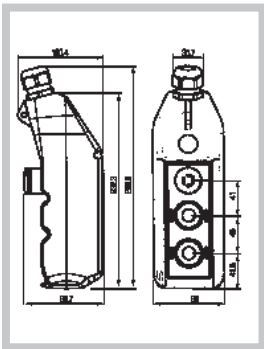
- Double insulated ABS enclosures
- IP65 protection rating according to IEC/EN 60529
- Ambient temperature:

Operating	-25° +70° °C
Storage	-40° +70° °C
- Slow break or snap action double gap contacts
- Cable entry with M25 cable clamp
- Rated insulation voltage U_i 500V
- Rated thermal current 25A
- Rated operating power:

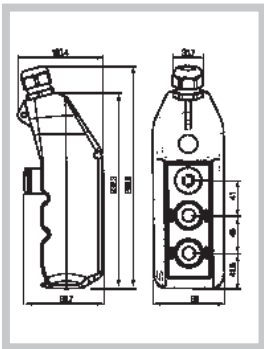
3-phase - 2-pole	230V ac kW	2.2
	400V ac kW	2.2
3-phase - 3-pole	230V ac kW	3
	400V ac kW	3





2 directions mechanically interlocked	ENGRAVING	DESCRIPTION	REFERENCE NO.	WEIGHT gr	DIMENSIONS
		For single/three-phase 1-speed motor direct control	DC30	600	
		No. 1 Emergency stop ø 30 turn to release EN418 with 1NC+1NO contacts and:			
		3NO+1NC Contact block			
		4NO Contact block	DC30.RG	600	
		For single/three-phase 1-speed motor direct control	DC30.GE	600	
		No. 1 Emergency stop ø 30 turn to release EN418 with 3 NC con- tacts and:			
		3NO+1NC Contact block			

Pendant stations

DC30 series pendant stations for power circuits
IP65 □ direct switching

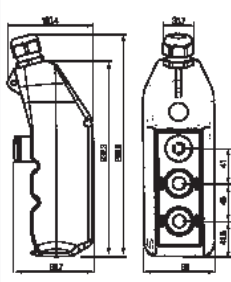

TECHNO-CONTROL EQUIPMENT

2 directions mechanically interlocked	ENGRAVING	DESCRIPTION	REFERENCE NO.	WEIGHT gr	DIMENSIONS
	  	For 2-speed motor direct control No. 1 Emergency stop ø 30 turn to release EN418 with 3NC contacts and: 2NO+2NC Contact block	DC30D2	650	

WIRING DIAGRAMS - POWER CIRCUITS

For single-speed reversing motors
30205085 (3NO+1NC) contact block

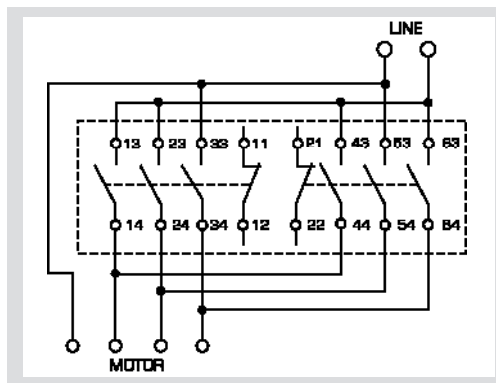

For single-speed reversing motors
30205087 (4NO) contact block

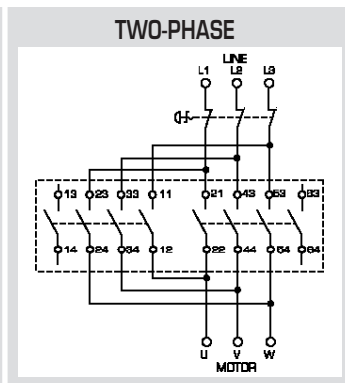
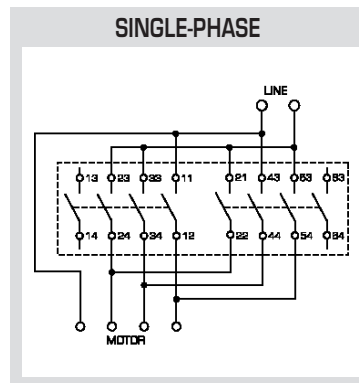

For two-speed reversing motors
30205086 contact block

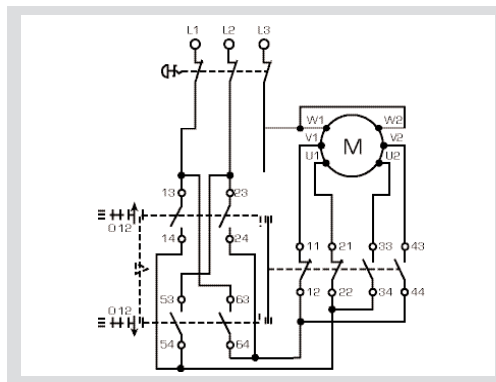

AUXILIARY CIRCUIT WIRING DIAGRAM

SINGLE-SPEED



FAST MOVEMENT

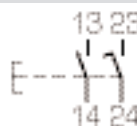

TWO-SPEED

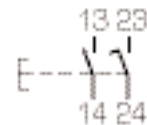

EMERGENCY

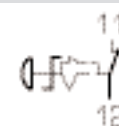

Pendant stations

DC30 series pendant stations for power circuits

Accessories

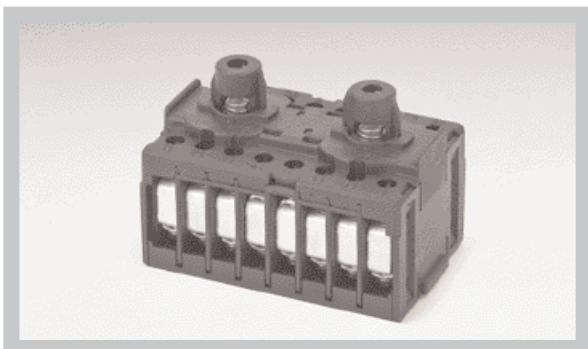

CONTACT BLOCK FOR SINGLE-SPEED REVERSING MOTORS

3NO+1NC
4NO

30205085
30205087

CONTACT BLOCK FOR TWO-SPEED REVERSING MOTORS

4NO
(2NO+2NC PROGRESSIVE)

30205086

Exploded
view

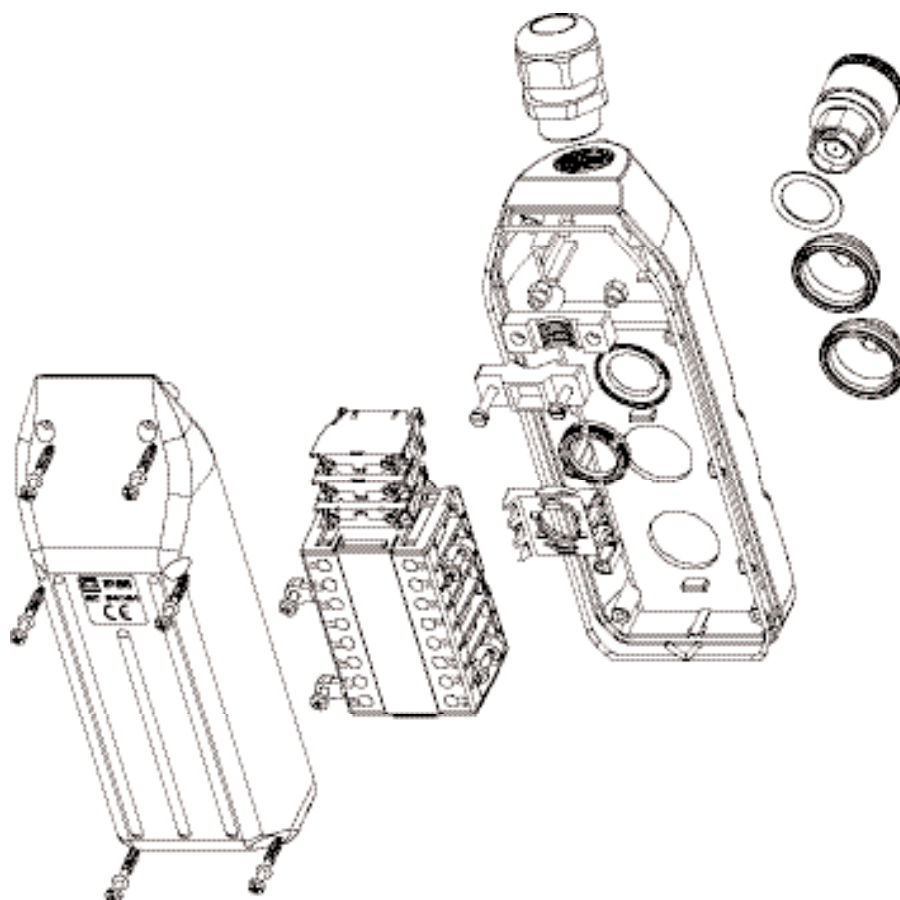

Pendant stations

TLP series push button stations for tail lifts

IP65 □ Spring loaded terminal contact blocks



TECHNO-CONTROL EQUIPMENT

GENERAL CHARACTERISTICS















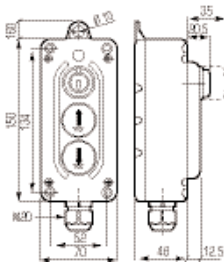





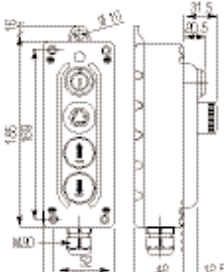

- Suitable for truck tail lifts
- Comply with UNI EN 1570 2001
- Heat resistant thermoplastic enclosure
- IP65 protection rating according to IEC/EN 60529
- Cable entry with No. 1 M20 cable clamp
- Suitable to be used both as pendant or fixed control station
- Laser printed push buttons

2 directions mechanically interlocked	ENGRAVING	DESCRIPTION	REFERENCE NO.	WEIGHT gr	DIMENSIONS
	 	<p>No. 1 UP push button with 1 NO contact</p> <hr/> <p>No. 1 COMMON push button with 1 NO contact</p> <hr/> <p>No. 1 DOWN push button with 1 NO contact</p>	TLP3.A	238	
	 	<p>No. 1 Emergency stop ø 30 turn to release EN418</p> <hr/> <p>No. 2 push buttons with 1 NO contact</p>	TLP3.B	255	

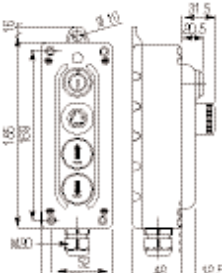
Pendant stations

TLP series push button stations for tail lifts

IP65 □ spring loaded terminal contact blocks

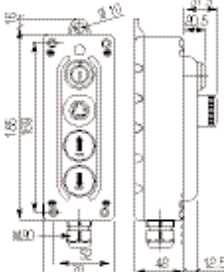
2 directions mechanically interlocked	ENGRAVING	DESCRIPTION	REFERENCE NO.	WEIGHT gr	DIMENSIONS
	  	<p>No. 1 90° angle key switch O-1 with 1 NO contact</p> <hr/> <p>No. 2 push buttons with 1 NO contact</p>	TLP3.C	255	
	   	<p>No. 1 Emergency stop ø 30 turn to release EN418</p> <hr/> <p>No. 1 UP push button with 1 NO contact</p> <hr/> <p>No. 1 COMMON push button with 1 NO contact</p> <hr/> <p>No. 1 DOWN push button with 1 NO contact</p>	TLP4.A	314	
	   	<p>No. 1 90° angle key switch O-1 with 1 NO contact</p> <hr/> <p>No. 1 Emergency stop ø 30 turn to release EN418</p> <hr/> <p>No. 2 push buttons with 1 NO contact</p>	TLP4.B	314	
	   	<p>No. 4 push buttons with 1 NO contact</p>	TLP4.C	297	

Pendant stations

P02 - PTRM - P03 - DC16 - PL - DC30 - TLP Series

Characteristics*



TECHNO-CONTROL EQUIPMENT

GENERAL CHARACTERISTICS

STANDARD COMPLIANCE	
Material group	
Pollution class	
Flame resistance	UL94
Ambient temperature	°C
	°C
Climate resistance	IEC 68 part 2-8
	IEC 69 part 2-30
Cable entry	rubber cable sleeve
	cable clamp

ELECTRICAL CHARACTERISTICS

CONTACT BLOCKS	
Rated insulation voltage U_i	V
Rated impulse voltage U_{imp}	kV
Rated thermal current I_{th}	A
Frequency	Hz
Rated operating current I_e:	
AC15 alternate current	V
DC13 direct current	A
	V
AC-3 alternate current	A
	230V kW
3-phase - 2-pole	400V kW
	230V kW
3-phase - 3-pole	400V kW
Conditional short circuit withstand current	A
Fuse rating gG	
Contact insulation resistance	mΩ
Switching mechanism	
Positive operation	
Terminal type	
Terminal capacity:	No. 1 Flexible and solid conductors min-max mm ²
	No. 2 Flexible and solid conductors min-max mm ²

P02-PTRM-P03 DC16-PL-TLP	DC30
IEC/EN60947-5-1	IEC/EN60947-3
II	II
3	3
VO	VO
Operating: -25+70	
Storage: -30 +70	
Hot damp	
Unsettled hot damp	
PL Ø 9...24	Ø 7...14
P02-P03-PTRM Ø 7...18	-
DC16 M25	M25
TLP M20	-

PL-P02-P03-PTRM-DC16-TLP	DC30
690	500
4	4
16	25
50	50
24 60 110 230 400 500 690	-
16 12 5 5 4 4 4	-
24 60 110 230	-
2 0,85 0,4 0,25	-
-	2.2
-	2.2
-	3
-	3
1000	1000
gG 10A-500V	aM 12A-500V
≤25	-
Slow break double gap contacts	
Positive opening NC contacts	-
M3.5 screw (spring loaded*)	M3.5 screw
1/2.5 (0.5/2.5*)	1/2.5
1/2.5 (0.5/2.5*)	1/2.5

* TLP Series with spring loaded terminal contact blocks

Reversing switches

For I3ORZ series power circuits

IP65 □ Lever operated

GENERAL CHARACTERISTICS

- Thermoplastic enclosure
- Lever operated with spring return in 0 position
- Coaxial shaft with safety limit switch
- IP65 protection rating according to IEC/EN 60529
- Thermoplastic enclosure
- Ambient temperature: operating -25 C°+70 C°
storage -40 C° +70 C°
- Material class II, Pollution class 3 according to IEC/EN60947-1
- Slow break or snap action double gap contacts
- Cable entry with No. 2 cable clamps 3/8"

■ Comply with IEC/EN60947-3, UL508	IEC/EN60947-3, UL508
■ Rated insulation voltage Ui	500V
■ Rated thermal current Ith	25A
■ Rated operating power:	
3-phase – 2-pole	230V ac kW 2.2
	400V ac kW 2.2
3-phase – 3-pole	230V ac kW 3
	400V ac kW 3

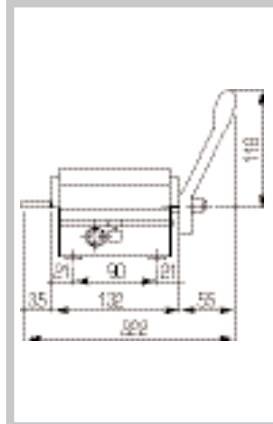
	DESCRIPTION	REFERENCE NO.	WEIGHT gr	DIMENSIONS
	For single-speed motor control			
	Lever operated reversing switch	I3ORZ	450	
	Spare components:			
	15° angled limit lever	30301045	10	
	45° angled limit lever	30301076	10	
Spare parts:				
Contact block	30205083	260		

Limit switches

FCR – FGR series

Table of contents



TECHNO-CONTROL EQUIPMENT

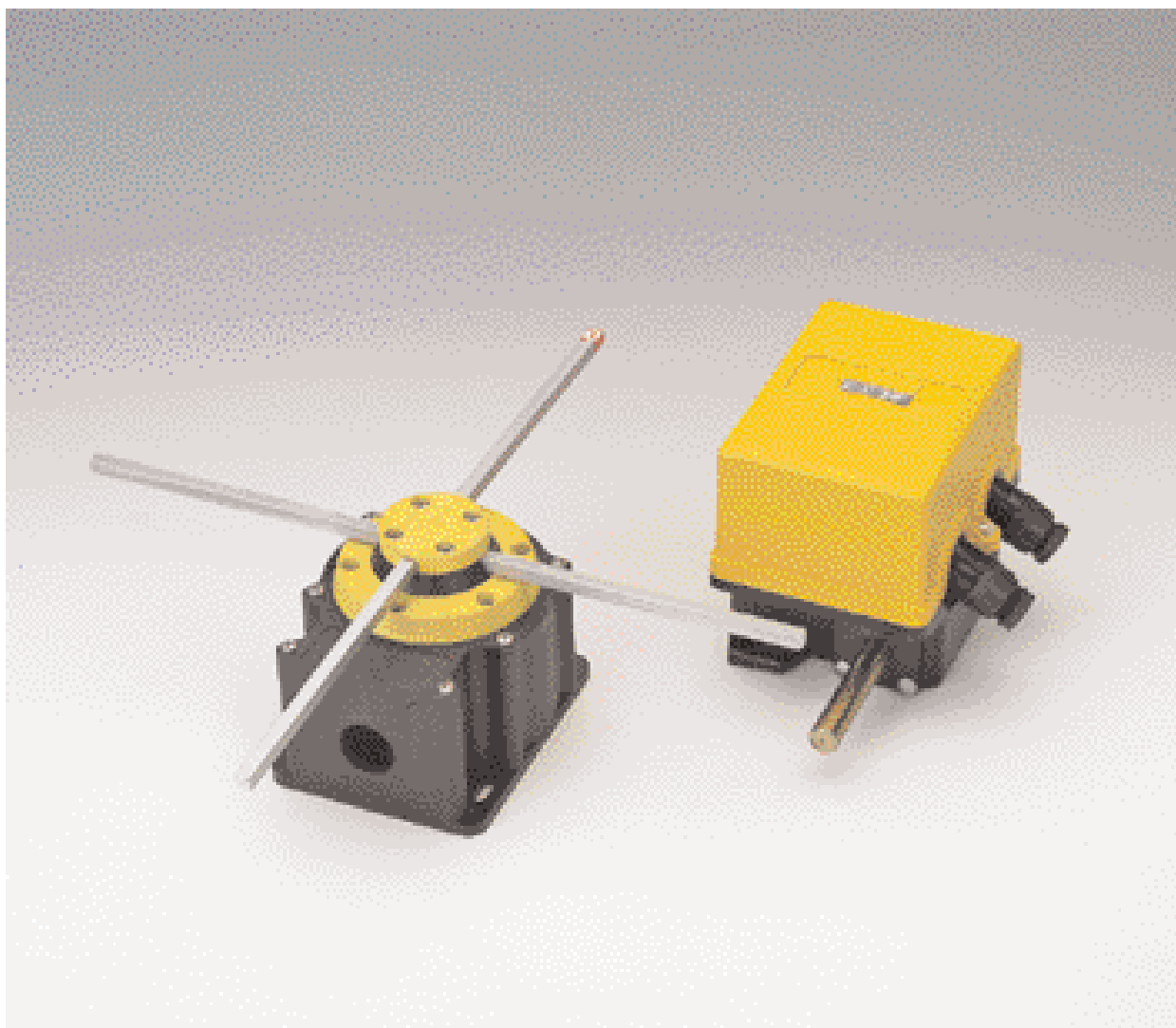

Rotary control switches with 300mm rods from 3 up to 5 positions. Control switches with rotary gear from 12 up to 200 rpm with 4 or 6 micro switches.

TABLE OF CONTENTS

- | | | | |
|---|----------|--|----------|
| ■ FCR series rotary limit switches for control circuits | pag. 134 | ■ FGR series rotary gear limit switch for control circuits | pag. 135 |
|---|----------|--|----------|

Rotary limit switches

FCR series for control circuits

IP65 □

GENERAL CHARACTERISTICS

- Self extinguishing thermoplastic housing VO UL94
- IP65 protection rating according to IEC/EN 60529
- Ambient temperature: operating -25° $+55^{\circ}$ C
storage -30° $+70^{\circ}$ C
- Material class II, Pollution class 3 according to IEC/EN60947
- Slow break positive opening double gap contacts \odot
- No.1 cable entry 22,5 \emptyset

ELECTRICAL CHARACTERISTICS

Comply with IEC/EN60947-3, UL508		
Certifications IMG, CCC, GOST, UL		
Rated insulation voltage U_i	V	690
Rated impulse withstand voltage U_{imp}	kV	4
Rated thermal current I_{th}	A	16
Frequency	Hz	50/60
Rated operating current: AC21A - AC22A	690V A	16
AC23A	3-phase - 3-pole	230V A/kW 13/4 400V A/kW 13/7,5
Rated short circuit withstand current (gG 20A-690V fuses)	kA	5

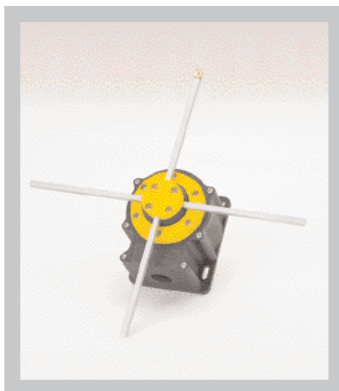

DESCRIPTION	REFERENCE NO.	WIRING DIAGRAM No.
For single-speed motor control		
3-position with mechanical interlock	FCR001	1
3-position with mechanical interlock	FCR002	2
4-position rotary	FCR003	3
4-position rotary	FCR004	4
4-position rotary	FCR005	5
For two-speed motor control		
4-position with mechanical interlock	FCR006	6

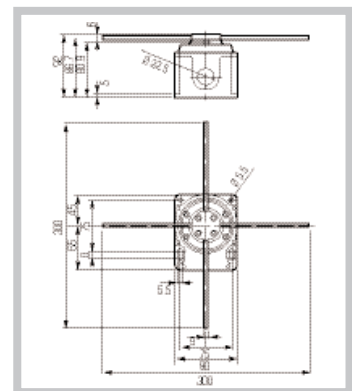

WIRING DIAGRAM 1

WITH MECHANICAL INTERLOCK



SINGLE-SPEED

WIRING DIAGRAM 2

WITH MECHANICAL INTERLOCK

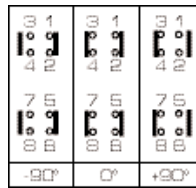

WIRING DIAGRAM 3

WITHOUT MECHANICAL INTERLOCK



SINGLE-SPEED

WIRING DIAGRAM 4

WITHOUT MECHANICAL INTERLOCK

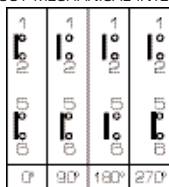

WIRING DIAGRAM 5

WITHOUT MECHANICAL INTERLOCK

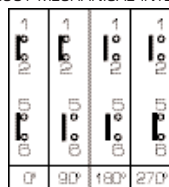

WIRING DIAGRAM 6

WITH MECHANICAL INTERLOCK

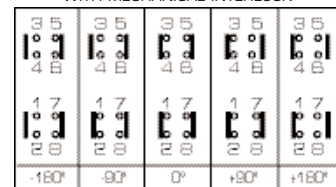

TWO-SPEED

Rotary gear limit switches

FGR series for control circuits

IP65 □



TECHNO-CONTROL EQUIPMENT

GENERAL CHARACTERISTICS

This range is aimed at the control of rotating parts: crane rope drums, machinery, etc.

They are supplied with a micro ,adjustable by a tool, to set the contacts to open and close independent from one another according to the different requirements.

The FGR..B version is supplied with a coaxial shaft to use an encoder.

- Die cast main body with self extinguishing thermoplastic cover VO
- IP65 protection rating according to IEC/EN 60529
- Galvanised steel worm gear with ball bearings
- PA control cams with central stainless steel shaft mounted on ball bearings
- Cams and micrometric adjustment screws in PA
- Maximum number of operating contacts 6 (6 cams)
- No.2 cable entries with M20 cable glands
- Σ Operating temperature -25° C + 70° C

ELECTRICAL CHARACTERISTICS

- Comply with IEC/EN 61058-1, UL 1054
- Certifications IMQ, CCC, GOST, UL Recognized
- 1NC+1NO changeover switches (C form)
- Snap action contacts with positive opening NC contact 
- Self cleaning silver alloy contacts
- Rated insulation voltage U_i 250V
- Rated thermal current 8A
- Rated operating current:
 - resistive load I_e 8A-250V ac
 - inductive load I_e 3A-250V ac
- IEC/EN 61058-1 8(3)A-250V ac, UL 1054 8A-250Vac

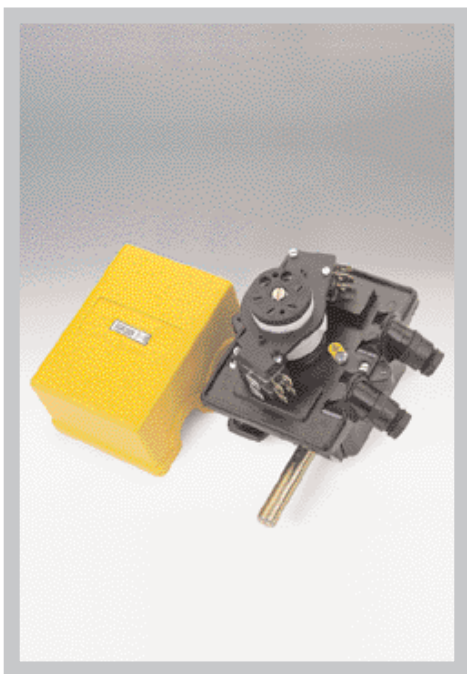

STANDARD VERSION

CAM/MOTORSHAFT REV RATIO	REFERENCE NO.		WEIGHT gr	MIN. PACK QTY.
	With 4 micro switches	With 6 micro switches		
1/12	FGR2006	FGR20066	1.100	1
1/33	FGR2007	FGR20076	1.100	1
1/50	FGR2008	FGR20086	1.100	1
1/100	FGR2009	FGR20096	1.100	1
1/200	FGR2010	FGR20106	1.100	1

COAXIAL SHAFT VERSION

CAM/MOTORSHAFT REV RATIO	REFERENCE NO.		WEIGHT gr	MIN. PACK QTY.
	With 4 micro switches	With 6 micro switches		
1/12	FGR2006B	FGR2006B6	1.200	1
1/33	FGR2007B	FGR2007B6	1.200	1
1/50	FGR2008B	FGR2008B6	1.200	1
1/100	FGR2009B	FGR2009B6	1.200	1
1/200	FGR2010B	FGR2010B6	1.200	1

Rotary gear limit switches

FGR series for control circuits

IP65 □

TRIP

The trip refer to the action of the cam on contact 1-2 (NC) of the micro-switches

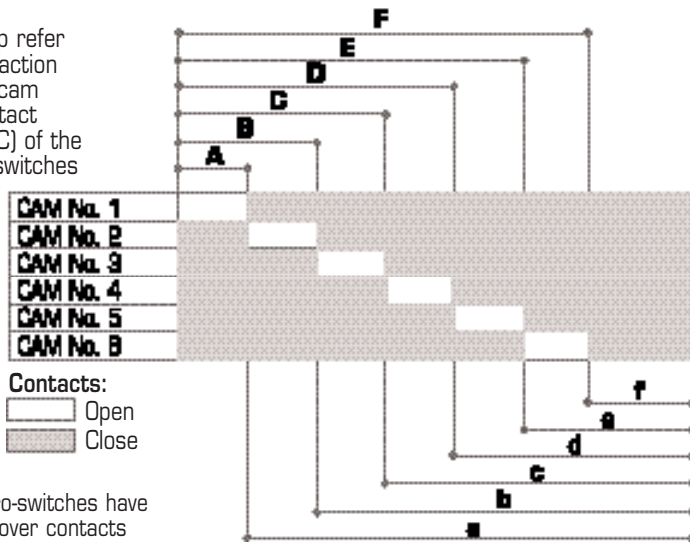

NOTE:
all micro-switches have changeover contacts

DIMENSIONS

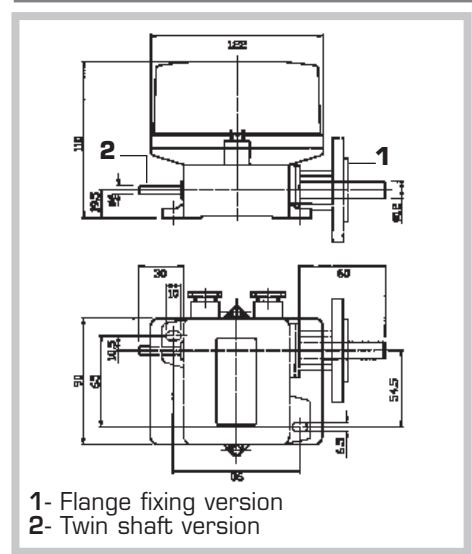

REVOLUTIONS REFERRED TO THE CAMS' ACTIVATION

RPM	A	a	B	b	C	c	D	d	E	e	F	f
12 revs	1,25	10,75	2,5	9,5	3,75	8,25	5	7	6,25	5,75	7,5	4,5
33 revs	3,5	29,5	7	26	10,5	22,5	14	19	17,5	15,5	21	13
50 revs	5	45	10	40	15	35	20	30	25	25	30	20
100 revs	10	90	20	80	30	70	40	60	50	50	60	40
200 revs	20	180	40	160	60	140	80	120	100	100	120	80

ACCESSORIES

The FLG flange in PA66, the Oldham coupling in PC reinforced with GF and the male connector in PA66 can be used on the main shaft. Special toothed cams can be made upon request.

FLANGE FLG

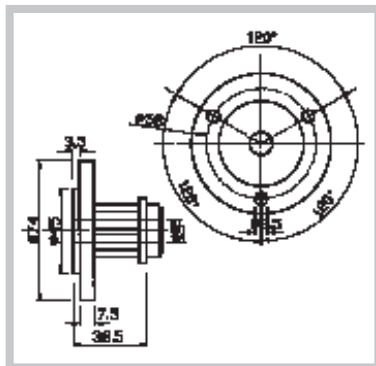

OLDHAM COUPLING FGH

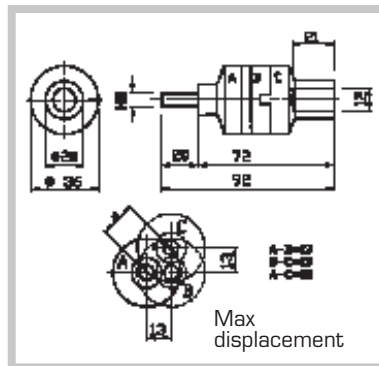

MALE COUPLING AM

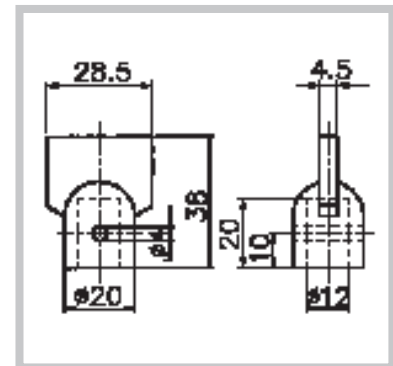

Slip rings

Scudo – Prisma - Navale series

Table of contents



TECHNO-CONTROL EQUIPMENT



20-50A slip rings from 3 up to 16 rings with open frame or protection rating up to IP65.

TABLE OF CONTENTS

■ Scudo – Prisma - Navale series Characteristics	pag. 138	■ Scudo – Prisma - Navale series Accessories and spare parts	pag. 140
■ Scudo – Prisma - Navale series Versions	pag. 139		

Slip rings

Scudo – Prisma - Navale series

Characteristics

Slip rings are used to transfer electrical signal and power energy between a stator (stationary portion of the slip ring) and a rotor. They are comprised of 3 or more graphite or metal contacts (brush) which rubs on the outside diameter of 3 or more metal rings. As the metal rings turn, the electrical current or signal is conducted through the brushes to the metal rings making the connection. Both parts can be either stator or rotor indifferently. Brushes are available in graphite (Prisma and Navale series) or copper (Scudo series) and can all be easily replaced.

OPERATING LIFE

The operating life of a slip ring is dependant upon the rotation speed and the dynamic stability. Hence it is important to make sure to avoid vibration of the rotor.

CURRENT RATING

Capacity can be increasing by connecting in series or parallel two or more slip rings.

GRAPHITE COLLECTORS

They are mainly used on low-medium speed applications. They are the most common in particular when more circuits are required as they ensure a very good connection, they withstand low and high temperatures, aggressive environments with presence of chemicals and humidity.

CHARACTERISTICS

SCUDO	PRISMA	NAVALE
<ul style="list-style-type: none"> Rated insulation voltage Ui 690V 	<ul style="list-style-type: none"> Rated insulation voltage Ui 690V 	<ul style="list-style-type: none"> Rated insulation voltage Ui 690V
<ul style="list-style-type: none"> Rated operating voltage Ue 500Vac 	<ul style="list-style-type: none"> Rated operating voltage Ue 500Vac 	<ul style="list-style-type: none"> Rated operating voltage Ue 500Vac
<ul style="list-style-type: none"> Rated operating current Ie 20A 	<ul style="list-style-type: none"> Rated operating current Ie 50A 	<ul style="list-style-type: none"> Rated operating current Ie 50A
<ul style="list-style-type: none"> Close frame version with IP51 protection rating 	<ul style="list-style-type: none"> Open frame 	<ul style="list-style-type: none"> Close frame version with IEC/EN60529 IP65 protection rating
<ul style="list-style-type: none"> Modularity: from 3 up to 15 80mm Ø rings 	<ul style="list-style-type: none"> Modularity: from 3 up to 16 100mm Ø rings 	<ul style="list-style-type: none"> Modularity: from 3 up to 15 100 mm Ø rings
<ul style="list-style-type: none"> Cu collectors 	<ul style="list-style-type: none"> Graphite collectors 	<ul style="list-style-type: none"> Graphite collectors
<ul style="list-style-type: none"> 42 mm Ø shaft 	<ul style="list-style-type: none"> 51 mm Ø shaft 	<ul style="list-style-type: none"> 51 mm Ø shaft with roller bearings and O-rings
<ul style="list-style-type: none"> PVC 147 mm Ø housing and terminal cover 		<ul style="list-style-type: none"> 280 mm Ø powder coated aluminium housing with protection against aggressive environments

Slip rings

Scudo - Prisma - Navale series

Versions



TECHNO-CONTROL EQUIPMENT

20A IP51 SCUDO SERIES



RINGS No.	REFERENCE No.	DIMENSION A
3	30402091	180
4	30402092	195
5	30402093	210
6	30402094	225
7	30402095	240
8	30402096	255
9	30402097	270
10	30402098	285
11	30402099	300
12	30402100	315
13	30402101	330
14	30402102	345
15	30402103	360

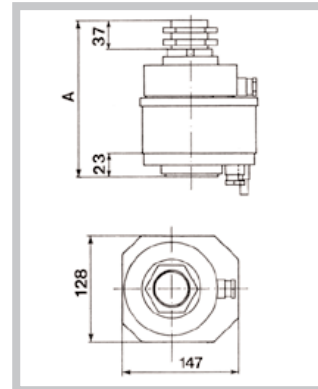

50A IPOO PRISMA SERIES



RINGS No.	REFERENCE No.	DIM. A	DIM. B
3	30402037	170	143
4	30402038	190	162
5	30402039	210	181
6	30402040	230	200
7	30402041	250	219
8	30402042	270	238
9	30402043	290	257
10	30402044	310	276
11	30402045	330	295
12	30402046	350	314
13	30402047	370	333
14	30402048	390	352
15	30402049	410	371
16	30402050	430	390

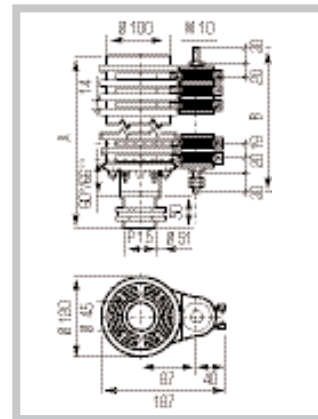

50A IP65 NAVALE SERIES



RINGS No.	REFERENCE No.	DIM. A	DIM. B
3	30403001	265	375
4	30403002		
5	30403003		
6	30403004		
7	30403005		
8	30403006		
9	30403007	470	570
10	30403008		
11	30403009		
12	30403010		
13	30403011		
14	30403012		
15	30403013		
16	30403014		

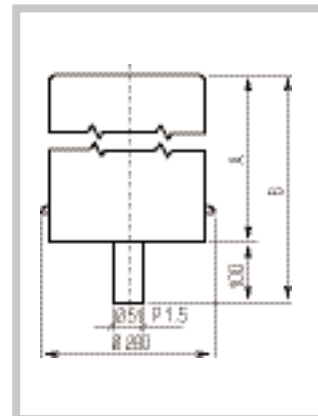

Slip rings

Scudo – Prisma - Navale series

Accessories and spare parts

GRAPHITE COLLECTORS

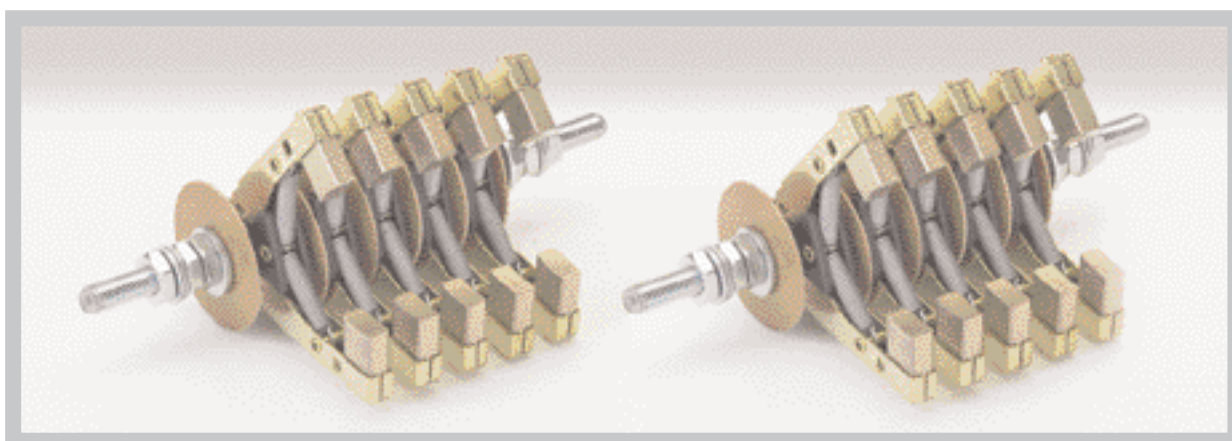

GRUPPO SPAZZOLE IN METALGRAFITE

■ 100 Ø yellow isolator	11702001	■ 6-ring collectors	12202017
■ Brush isolator	11702004	■ 7-ring collectors	12202018
■ Collector terminals	11702005	■ 8-ring collectors	12202019
■ 16-hole cable entry head	11708056	■ 9-ring collectors	12202020
■ Single collector	12202033	■ 10-ring collectors	12202021
■ Collector carbide	12202034	■ 11-ring collectors	12202022
■ Aluminium hexagon	21005005	■ 12-ring collectors	12202023
■ Aluminium fixing flange	21005007	■ 13-ring collectors	12202024
■ 100 Ø brass ring	21005010	■ 14-ring collectors	12202025
■ 3-ring collectors	12202015	■ 15-ring collectors	12202027
■ 4-ring collectors	12202016	■ 16-ring collectors	12202028
■ 5-ring collectors	12202026		

Warning horns

AA series

G100 IP65 - G75 IP30



TECHNO-CONTROL EQUIPMENT

SINGLE TONE WARNING HORNS

Generally used in the industrial sector and handling equipment in general such as trucks, fork lifts, etc.

CHARACTERISTICS:

- Operation: continuous
- Frequency: 300-350 Hz G100 series, 50 Hz G75 series
- Pressure (at 1 meter): 95.3 dB (A), G100 series, 88 dB (A) G75 series
- Wall mounted
- IEC/EN60529 protection rating: IP65 G100 series, IP30 G75 series
- Terminal type: 2 way terminal bar G100 series, 3 way terminal (2P+E) bar G75 series

G100 series - Double insulated

G75 Ø 75

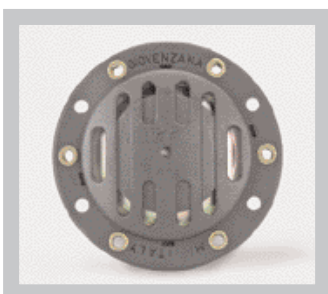

POWER SUPPLY Volt	CONSUMPTION mA	REFERENCE No.	WEIGHT gr	MIN. PACK QTY.
24 AC	190	G75.24	120	4/12
48 AC	80	G75.48		
110 AC	28	G75.110		
230 AC	20	G75.230		
24 DC	40	G75.24DC		
48 DC	-	G75.48DC		
110 DC	-	G75.110DC		
230 DC	-	G75.230DC		

G100 Ø 100

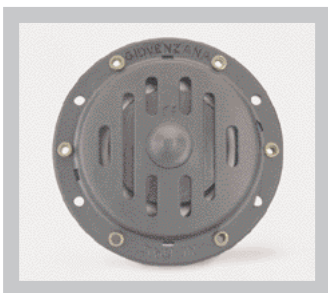

24 AC	415	G100.24	305	2/12
48 AC	210	G100.48		
110 AC	90	G100.110		
230 AC	42	G100.230		

BACK BOX

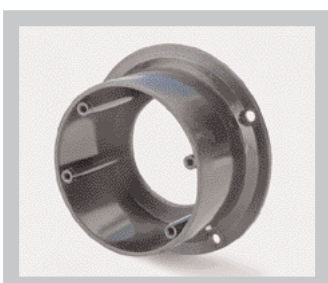

DIMENSIONS

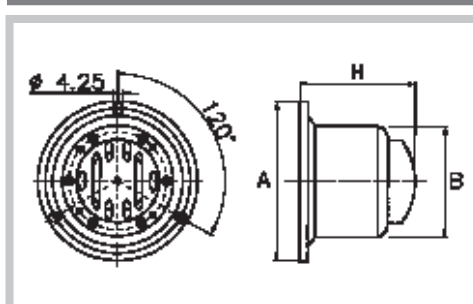

	G75	G100
A	Ø 95.5	Ø 120
B	Ø 76.5	Ø 95.5
H	56	58

Per G75 **11710009**
Per G100 **11710010**

Overall dimensions include the back box

Energy and data transmission

28 - 30 - 41 - Wire rope - I-beam - TR 85 series

Table of contents



TECHNO-CONTROL EQUIPMENT

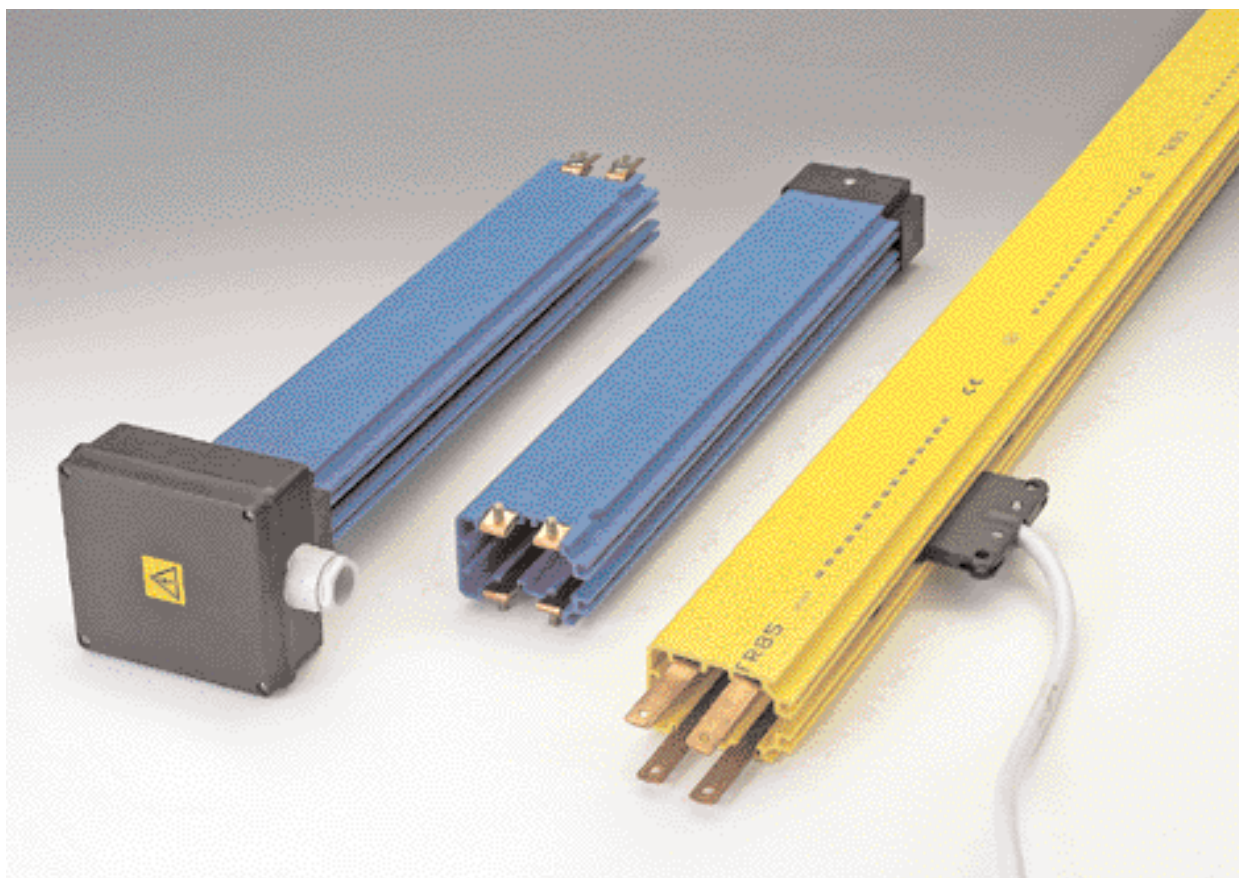

The festoon system includes 28, 30, 41 series c-rail cable trolleys; wire rope cable trolleys; I-beam cable trolleys. The TR85 series conductor rail range offers both plug-in (Line **A**) or continuous strip (Line **B**) type systems.

TABLE OF CONTENTS

■ 28 series festoon system	pag. 144	■ TR85 series conductor rails	pag. 156
■ 30 series festoon system	pag. 147	■ TR85 series conductor rails Line A Plug-in type	pag. 157
■ 41 series festoon system	pag. 150	■ TR85 series conductor rails Line B Continuous strip type	pag. 160
■ Wire rope series	pag. 153	■ Accessories - TR85 series spare parts	pag. 163
■ Light I-beam series	pag. 154		
■ Heavy I-beam series	pag. 155		



Energy and data transmission

28 Series

Festoon system



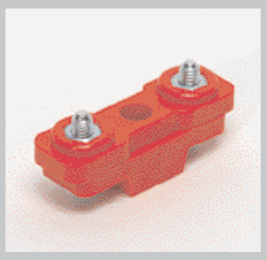
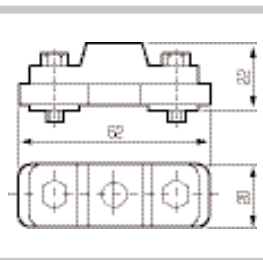
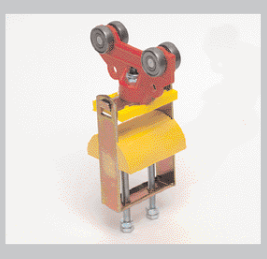
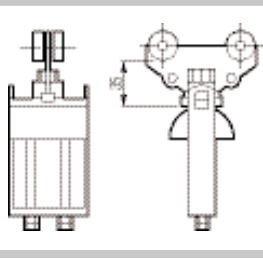
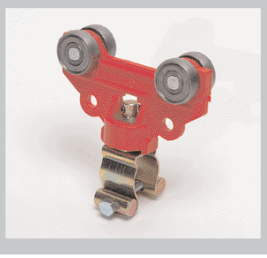
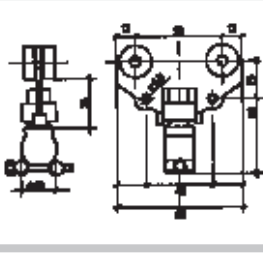
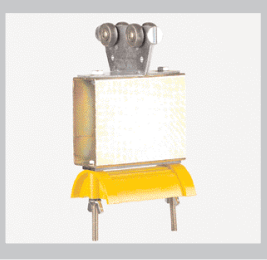
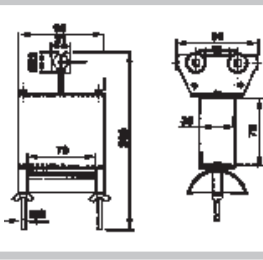

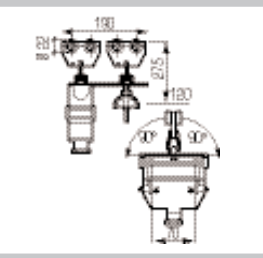



TECHNO-CONTROL EQUIPMENT

	DESCRIPTION	REFERENCE No.	MIN. PACK QTY.	DIMENSIONS
	<p>End stop</p> <ul style="list-style-type: none"> Material: PA 6 	30603005	1	
	<p>Flat cable trolley</p> <p>Round cable trolley with rotating saddle</p> <ul style="list-style-type: none"> Material: PA 6 Type of roller: steel roller with ball bearings. Travel speed 80 m/min. Load capacity: 55 mm plastic saddle 	30603008	10	
	<p>Round cable trolley with metal cable clip</p> <ul style="list-style-type: none"> Max cable diameter: 18 mm Material: PA 6 Type of roller: steel roller with ball bearings. Travel speed 80 m/min. Load capacity: 15kg 	30603024	10	
	<p>Towing trolley</p> <ul style="list-style-type: none"> Material: galvanised steel Type of roller: steel roller with ball bearings. Travel speed 80 m/min. 68 mm plastic saddle 	30603064	1	
	<p>Trolleys with Plug and Socket Connections</p> <p>To connect the festoon system to the pendant station</p> <ul style="list-style-type: none"> 68 mm plastic saddle 16-pole 24-pole 	30603066	1	
		30603067	1	

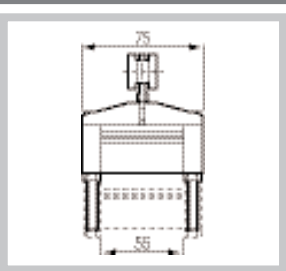
Energy and data transmission

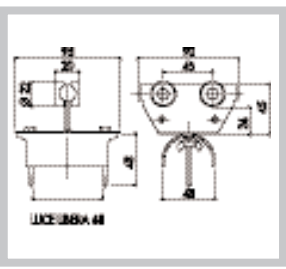
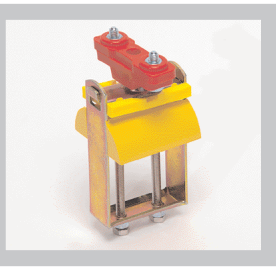
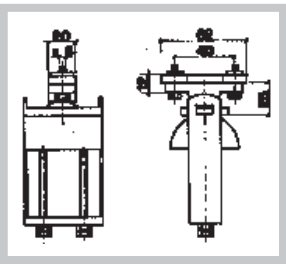
28 Series

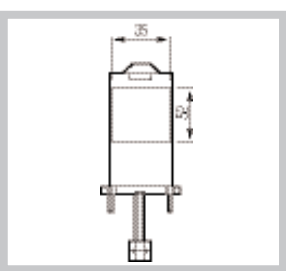
Festoon system

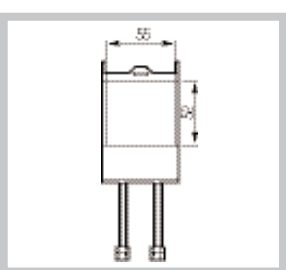
	DESCRIPTION	REFERENCE No.	MIN. PACK QTY.	DIMENSIONS
	<p>Light series trolley Main body, saddle and wheels in PA for a considerable noise reduction</p> <ul style="list-style-type: none"> ■ Type of roller: PA roller. Travel speed 40 m/min. ■ Load capacity: 10 Kg. ■ 55 mm plastic saddle 	30603035	10	
	<p>Steel trolley</p> <ul style="list-style-type: none"> ■ Material: galvanised steel ■ Type of roller: steel roller with ball bearings. Travel speed 80 m/min. ■ Load capacity: 15 Kg. ■ 68 mm steel saddle 	30603061	10	
	<p>End clamp</p> <ul style="list-style-type: none"> ■ Material: PA 6 ■ Load capacity: 15 Kg. ■ 55 mm plastic saddle ■ 68 mm plastic saddle ■ Metal cable clip 	<p>30603016</p> <p>30603065</p> <p>30603018</p>	<p>1</p> <p>1</p> <p>1</p>	
	<p>40 mm plastic saddle</p> <ul style="list-style-type: none"> ■ Material: PA 6 and galvanised steel 	30603030	10	
	<p>55 mm plastic saddle</p> <ul style="list-style-type: none"> ■ Material: PA 6 and galvanised steel 	30603031	10	

Energy and data transmission

30 Series

Festoon system



TECHNO-CONTROL EQUIPMENT

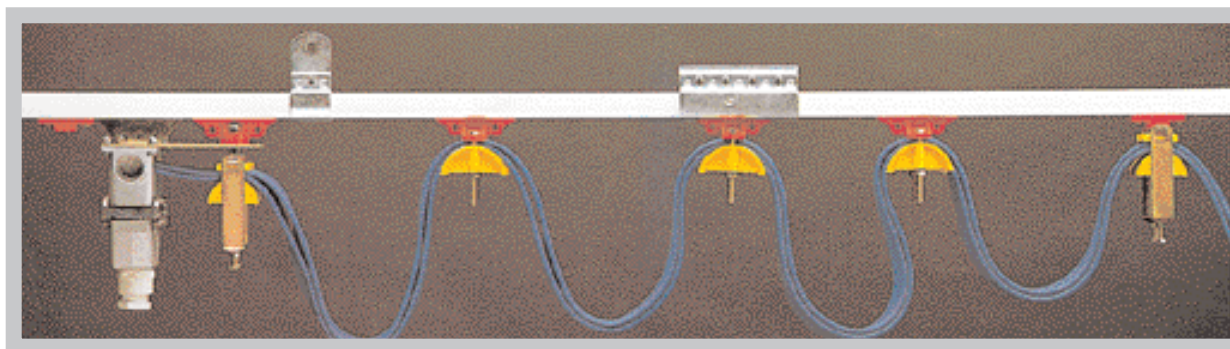

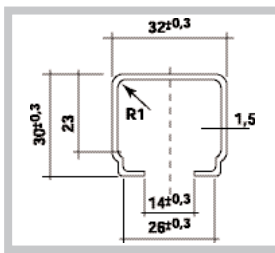
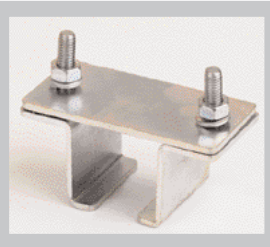
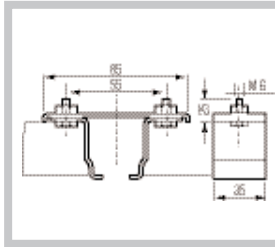
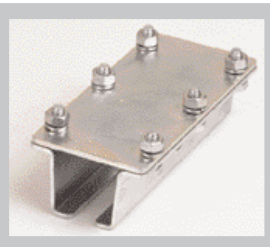
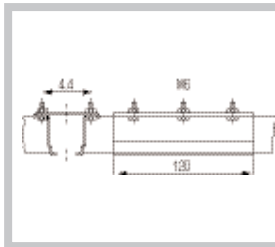
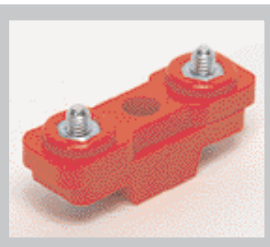
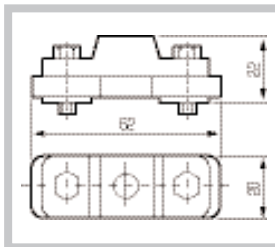

	DESCRIPTION	REFERENCE No.	MIN. PACK QTY.	DIMENSIONS
	<p>C-rail bars</p> <ul style="list-style-type: none"> Material: galvanised steel Length: 4 m Weight: 5 kg Load capacity: 140 kg/m 	30607001	1	
	<p>Track support bracket (2 pieces)</p> <ul style="list-style-type: none"> Material: galvanised steel Max support spacing: 1 m (recommended) 	30607003	1	
	<p>Track coupler bracket To join c-rails and suitable for supporting the track</p> <ul style="list-style-type: none"> Material: Galvanised steel 	30607002	1	
	<p>End stop</p> <ul style="list-style-type: none"> Material: PA 6 	30607005	1	

Energy and data transmission

30 Series

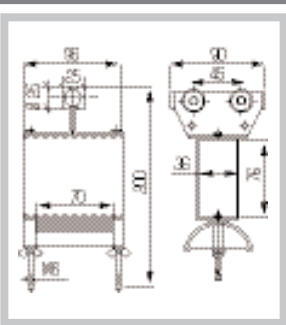
Festoon system

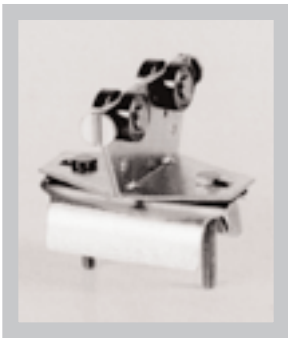
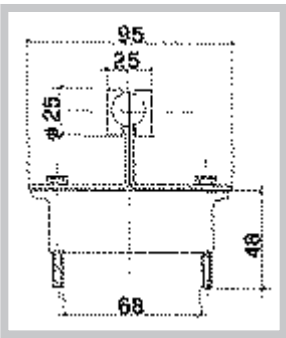
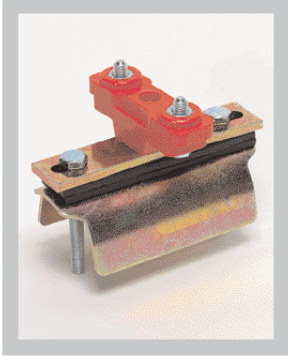
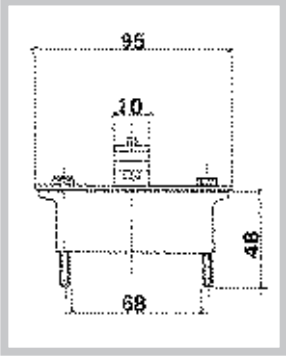
	DESCRIPTION	REFERENCE No.	MIN. PACK QTY.	DIMENSIONS
	<p>Towing trolley</p> <ul style="list-style-type: none"> ■ Material: galvanised steel ■ Type of roller: steel roller with ball bearings. Travel speed 80 m/min. ■ 68 mm plastic saddle 	<p>30607007</p>	<p>1</p>	
	<p>Trolleys with Plug and Socket Connections</p> <ul style="list-style-type: none"> ■ To connect the festoon system to the pendant station ■ 68 mm plastic saddle ■ 16-pole ■ 24-pole 			<p>30607008 30607019</p>
	<p>Trolley</p> <ul style="list-style-type: none"> ■ Material: galvanised steel ■ Type of roller: steel roller with ball bearings. ■ 68 mm steel saddle ■ Material: PA 6 ■ Type of roller: PA roller. ■ 55 mm plastic saddle ■ Material: galvanised steel ■ Type of roller: PA roller. ■ 68 mm steel saddle 	<p>30607010 30607011 30607009</p>	<p>10 10 10</p>	
	<p>End clamp</p> <ul style="list-style-type: none"> ■ Material: PA 6/Galvanised steel ■ 68 mm steel saddle 	<p>30607006</p>	<p>1</p>	

Energy and data transmission

41 Series

Festoon system

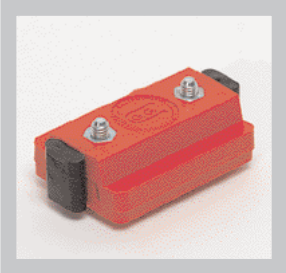
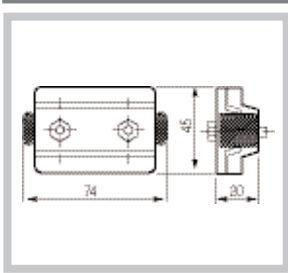
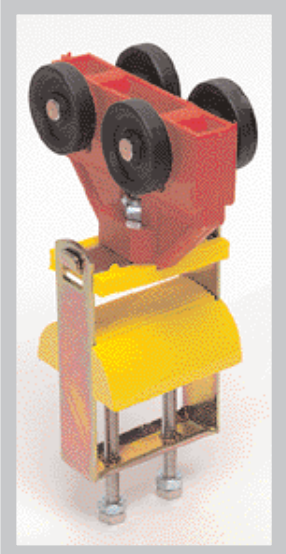
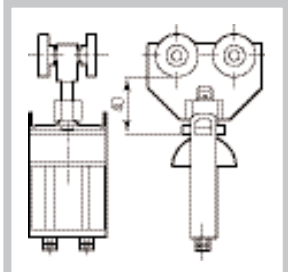
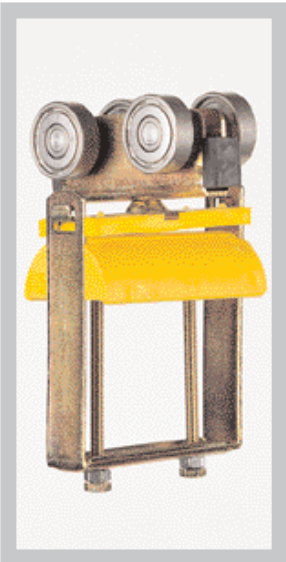
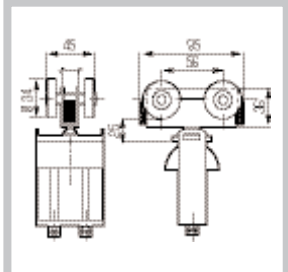

TECHNO-CONTROL EQUIPMENT

	DESCRIPTION	REFERENCE No.	MIN. PACK QTY.	DIMENSIONS
	<p>End stop</p> <ul style="list-style-type: none"> Material: PA 6 Support PVC buffer 	30602038	1	
	<p>Flat cable trolley</p> <ul style="list-style-type: none"> Material: PA 6 Type of roller: PA roller. Travel speed 60 m/min. Load capacity: 15 Kg. 40 mm plastic saddle 55 mm plastic saddle 	30602012	10	
	<p>Round cable trolley</p> <ul style="list-style-type: none"> Material: PA 6 Type of roller: PA roller. Travel speed 60 m/min. Load capacity: 15 Kg. 40 mm plastic saddle 55 mm plastic saddle 	30602013	10	
	<p>Flat cable trolley</p> <ul style="list-style-type: none"> Material: Galvanised steel Type of roller: steel roller with ball bearings. Travel speed 120 m/min. Load capacity: 25 Kg. 40 mm plastic saddle 55 mm plastic saddle 68 mm plastic saddle 	30602076	10	
	<p>Round cable trolley</p> <ul style="list-style-type: none"> Material: Galvanised steel Type of roller: steel roller with ball bearings. Travel speed 120 m/min. Load capacity: 25 Kg. 40 mm plastic saddle 55 mm plastic saddle 	30602082	10	
		30602083	10	

Energy and data transmission

Wire rope series



Ø 8 rope festoon system



TECHNO-CONTROL EQUIPMENT

CHARACTERISTICS

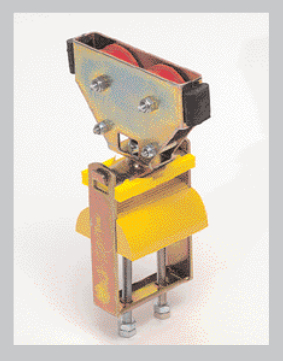
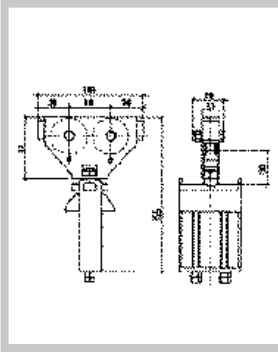
- Wire rope festoon systems are used in cases where c-rail and I-beam track power supplies are difficult to install.
- Rope diameter: Ø 8
- Trolleys for flat or round cables
- Travel speed: 40 m/min.
- Trolley load capacity: 8 kg

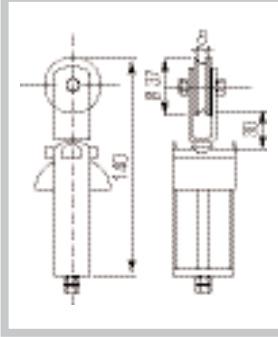
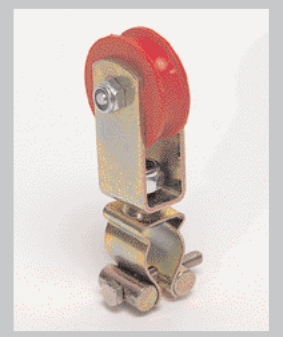
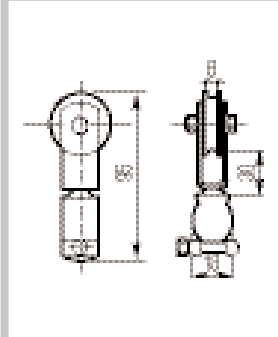
	DESCRIPTION	REFERENCE No.	MIN. PACK QTY.	DIMENSIONS
	<p>Two-roller trolley</p> <ul style="list-style-type: none"> ■ Material: galvanised steel/PA 6 ■ Type of roller: PA roller. Travel speed 40 m/min. ■ Rotating 55 mm plastic saddle ■ Load capacity: 8 kg ■ Rope: Ø 8 	30604003	10	
	<p>Single-roller trolley</p> <ul style="list-style-type: none"> ■ Material: galvanised steel/PA 6 ■ Type of roller: PA roller. Travel speed 40 m/min. ■ Rotating 40 mm plastic saddle ■ Load capacity: 8 kg ■ Rope: Ø 8 	30604005	10	
	<p>Single-roller trolley With metal cable clip</p> <ul style="list-style-type: none"> ■ Max cable diameter: 18 mm ■ Material: galvanised steel ■ Type of roller: PA roller. Travel speed 40 m/min. ■ Load capacity: 8 kg ■ Rope: Ø 8 	30604007	10	

Energy and data transmission

Light series

I-beam

CHARACTERISTICS

- Festoon systems for IPE-IPN steel beam are suitable for heavy duty applications (motor power supply in steel plants, cranes, mills, docks, etc.)
- IPE-IPN 80-100 beam
- Travel speed: 120 m/min.
- Max trolley load capacity: 50 kg
- Maximum cable package window opening height of 40 mm for both flat and round cables

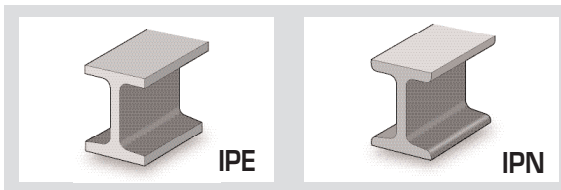

TROLLEY				
BEAM	IPE 80		IPN 80	
Saddle mm	55	85	55	85
PA rollers	30606003	30606005	30606004	30606006
Steel rollers	30606103	30606105	30606104	30606106
BEAM	IPE 100		IPN 100	
Saddle mm	55	85	55	85
PA rollers	30606011	30606013	30606012	30606014
Steel rollers	30606111	30606113	30606112	30606114

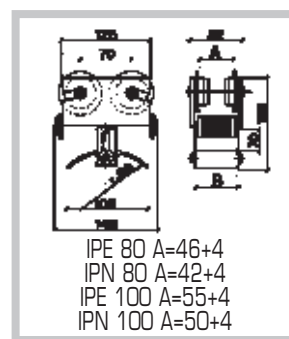

TOWING TROLLEY				
BEAM	IPE 80		IPN 80	
Saddle mm	55	85	55	85
PA rollers	30606033	30606035	30606034	30606036
Steel rollers	30606133	30606135	30606134	30606136
BEAM	IPE 100		IPN 100	
Saddle mm	55	85	55	85
PA rollers	30606041	30606043	30606042	30606044
Steel rollers	30606141	30606143	30606142	30606144

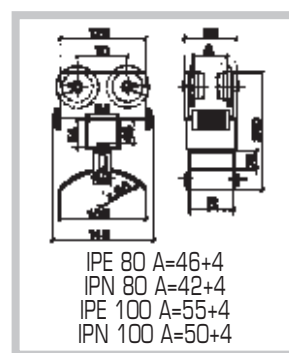

END CLAMP				
BEAM	IPE 80 - IPN80		IPE 100 - IPN 100	
Saddle mm	55	85	55	85
Reference No.	30606062	30606063	30606066	30606067

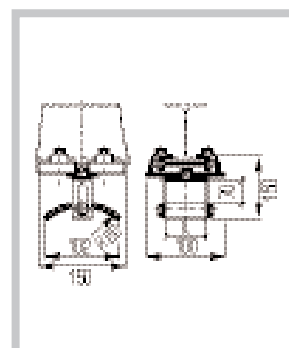

Energy and data transmission

Light series

I-beam



TECHNO-CONTROL EQUIPMENT

CHARACTERISTICS

- Festoon systems for IPE-IPN steel beams are suitable for heavy duty applications (motor power supply in steel plants, cranes, mills, docks, etc.)
- IPE-IPN 80-120 beam
- Travel speed: 120 m/min.
- Max trolley load capacity: 200 kg
- Maximum cable package window opening height of 50 mm for both flat and round cables

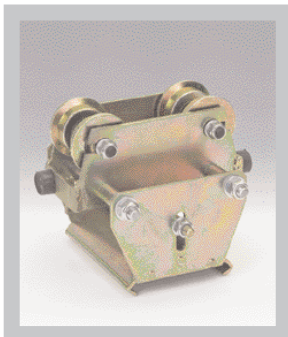
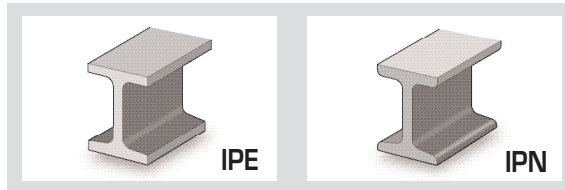

TROLLEY				
BEAM	IPE 80		IPN 80	
Saddle mm	100	160	160	180
Steel rollers	30605001	30605002	30605003	30605004
BEAM	IPE 100		IPN 100	
Saddle mm	160	180	160	180
Steel rollers	30605005	30605006	30605007	30605008
BEAM	IPE 120		IPN 120	
Saddle mm	160	180	160	180
Steel rollers	30605009	30605010	30605011	30605012

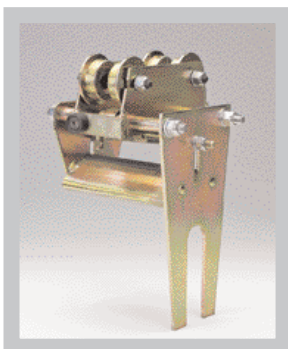
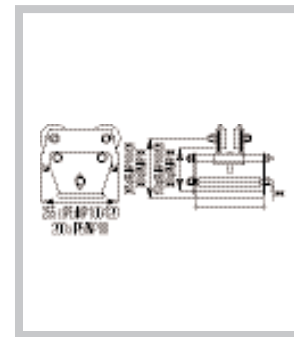

TOWING TROLLEY				
BEAM	IPE 80		IPN 80	
Saddle mm	100	160	160	180
Steel rollers	30605013	30605014	30605015	30605016
BEAM	IPE 100		IPN 100	
Saddle mm	160	180	160	180
Steel rollers	30605017	30605018	30605019	30605020
BEAM	IPE 120		IPN 120	
Saddle mm	160	180	160	180
Steel rollers	30605021	30605022	30605023	30605024

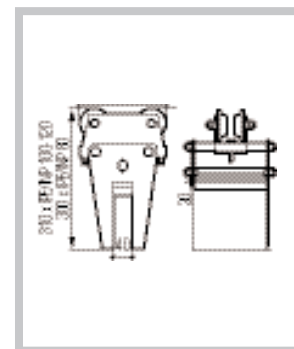

END CLAMP		
BEAM	IPE 80 - IPN 80	
Saddle mm	100	160
Steel rollers	30605025	30605026
BEAM	IPE 100 - IPN 100	
Saddle mm	160	180
Steel rollers	30605027	30605028
BEAM	IPE 120 - IPN 120	
Saddle mm	160	180
Steel rollers	30605029	30605030

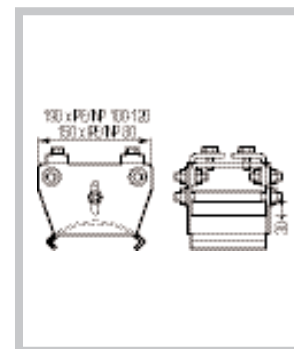

Energy and data transmission

TR85 Series

Conductor rails

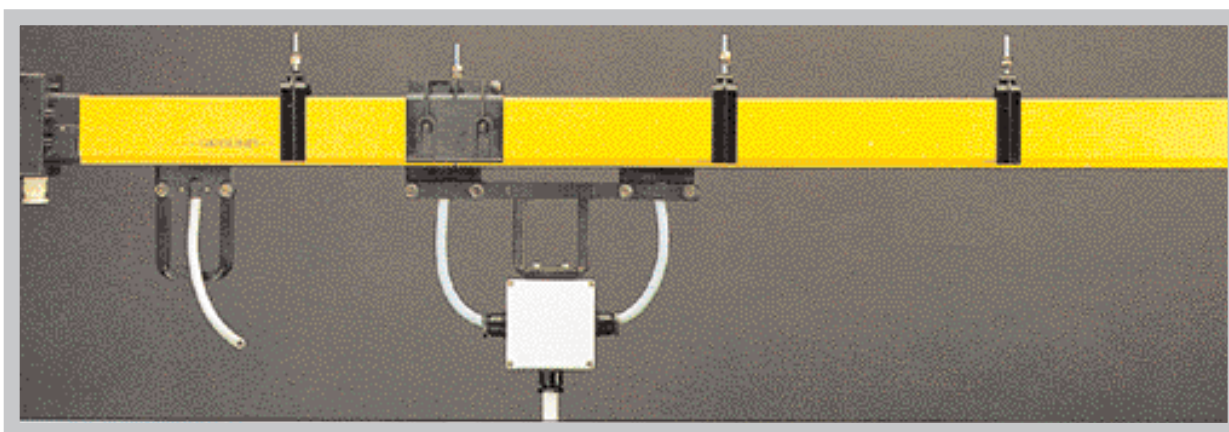

CHARACTERISTICS

The TR85 series conductor rails are a modern and safe system for energy and data transmission for various type of equipment such as: CRANES - BRIDGE CRANES - CONVEYOR BELTS – CHAIN CONVEYORS - etc. The TR85 range comply with the relevant international standards ensuring operator safety, ease of installation and reliability. The system is available in the following versions:

- A) With conductors already inside the plastic casing. Copper strips are connected by means of dedicated terminals.
- B) With current strips to be pulled from a coil continuously into the pre-assembled plastic casings with the aid of a towing trolley in case of long systems.

PLASTIC CASING TECHNICAL CHARACTERISTICS: YELLOW R15C TYPE PVC

CHARACTERISTICS	TEST		METERING UNIT	
Transparency			ok/no	NO
Specific weight	ISO R	1183	Kg/dm ³	1,44
Shore hardness	ISO R	868		D83
Vicat softening temperature - 5 kg	ISO R	306	°C	82
IZOD +23 °C	ISO R	180	Kg/Cm ²	10
IZOD 0 °C	ISO R	180	Kg/Cm ²	5,5
IZOD -10 °C	ISO R	180	Kg/Cm ²	3
Ultimate tensile strength	ISO R	527	Kg/Cm ²	430
Yield point	ISO R	527	Kg/Cm ²	460
Modulus of elasticity	ISO R	178	Kg/Cm ²	30000
Flammability	UL	94		V0
Flammability	DIN	4102		B2
Flammability	D.M.	6/7/83		Cl

SEALING STRIP TECHNICAL CHARACTERISTICS: BLACK WE/706 TYPE PVC

Specific weight	1,45/Cm ³
Shore hardness at 15"	81
Breaking point	1,45
Elongation	340%
Cold resistance	-30 °C
Volume resistance	3x10 ¹³
Protection rating	IP20 - IP23

TECHNICAL DATA

Operating voltage 600V

Operating temperature -30°C +55°C (-22°F +130°F)

CURRENT RATING AMP	CONDUCTOR CROSS SECTIONAL AREA mm ²	IMPEDENCE Ω/ m.	RESISTANCE V/m./Amp.
40	9,3	2.10 ³	0,00346
60	12,4	1,75.10 ³	0,00303
70	15,5	1,30.10 ³	0,00250
80	17	1,18.10 ³	0,00204
100	21,7	1.10 ³	0,00173
140	31	0,75.10 ³	0,00123

Energy and data transmission

TR85 Series

Conductor rails - Line A "Plug-in" type



TECHNO-CONTROL EQUIPMENT

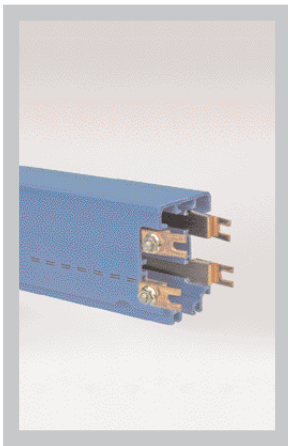

CONDUCTOR RAIL

Ends with provision for the TR 8515 joint clamps

LENGTH (m)	POLES	CURRENT RATING		
		40A	60A	80A
3	4	TR85404C3	TR85604C3	TR85804C3
	5	TR85405C3	TR85605C3	TR85805C3
4	4	TR85404C	TR85604C	TR85804C
	5	TR85405C	TR85605C	TR85805C
LENGTH (m)	POLES	CURRENT RATING		
		100A	140A	
3	4	TR851004C3	TR851404C3	
	5	TR851005C3	TR851405C3	
4	4	TR851004C	TR851404C	
	5	TR851005C	TR851405C	

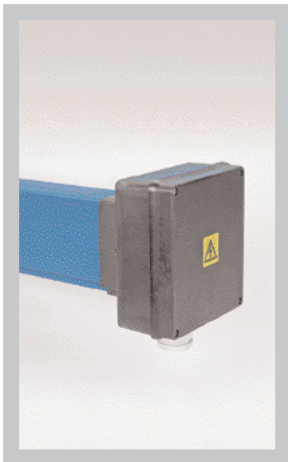
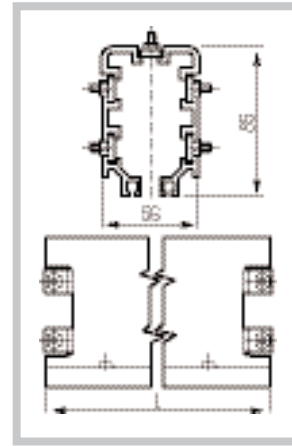

END FEED

Standard length 2 m

LENGTH (m)	POLES	CURRENT RATING		
		40A	60A	80A
2	4	TR85404A2	TR85604A2	TR85804A2
	5	TR85405A2	TR85605A2	TR85805A2
LENGTH (m)	POLES	CURRENT RATING		
		100A	140A	
2	4	TR851004A2	TR851404A2	
	5	TR851005A2	TR851405A2	

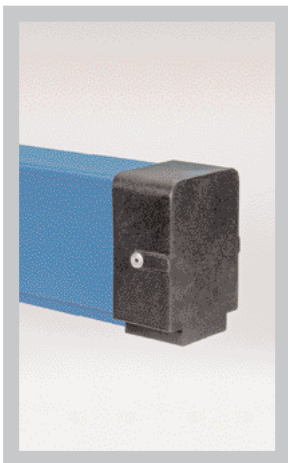
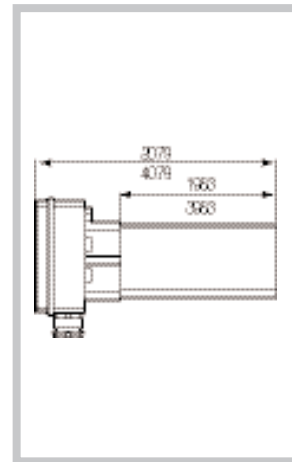

END CAP

Standard length 2 m



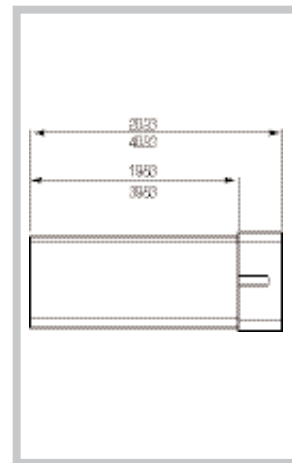



LENGTH (m)	POLES	CURRENT RATING		
		40A	60A	80A
2	4	TR85404F2	TR85604F2	TR85804F2
	5	TR85405F2	TR85605F2	TR85805F2
LENGTH (m)	POLES	CURRENT RATING		
		100A	140A	
2	4	TR851004F2	TR851404F2	
	5	TR851005F2	TR851405F2	

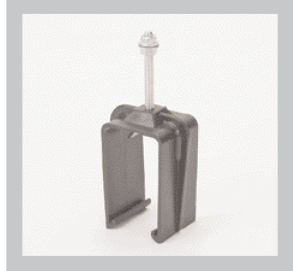
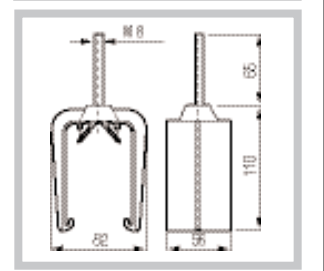

Energy and data transmission

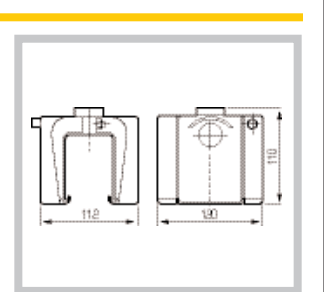
TR85 Series

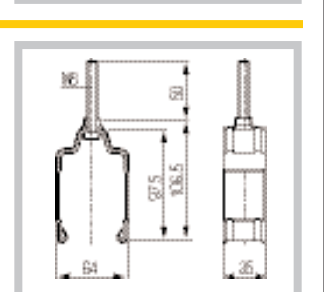
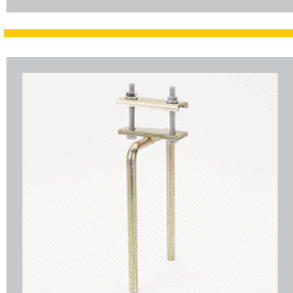
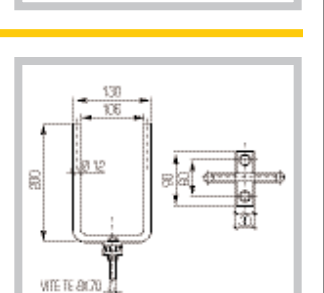
Conductor rails - Line A "Plug-in" type

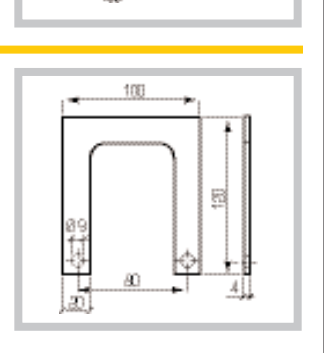
	DESCRIPTION	REFERENCE No.	MIN. PACK QTY.	DIMENSIONS
	<p>Hanger clamp</p> <ul style="list-style-type: none"> Material: PA 66 Max support spacing: 2 m (recommended) 	TR8502	1	
	<p>Joint cover</p> <ul style="list-style-type: none"> Material: PA 6 	TR8504	1	
	<p>Steel hanger clamp</p> <ul style="list-style-type: none"> Material: Galvanised steel 	TR8525	1	
	<p>Towing arm</p> <ul style="list-style-type: none"> Material: Galvanised steel 	TR8510	1	
	<p>Towing arm bracket</p> <p>For 35A and 70A current collectors</p> <ul style="list-style-type: none"> Material: Galvanised steel 	TR8508	1	

Energy and data transmission

TR85 Series

Conductor rails - Line B "Continuous strip" type

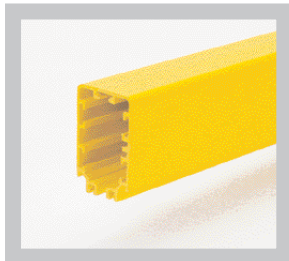

CONDUCTOR RAIL

Standard length 4 m

LENGTH (m)		CURRENT RATING		
		70A	100A	140A
4	4	TR85704	TR851004	TR851404
	5	TR85705	TR851005	TR851405

Conductors are supplied separately. The copper strip is pulled from a coil into the plastic casing with the aid of the TR8513 de-coil unit and TR8514 strip insertion trolley

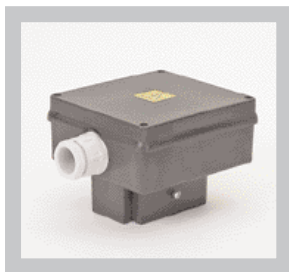
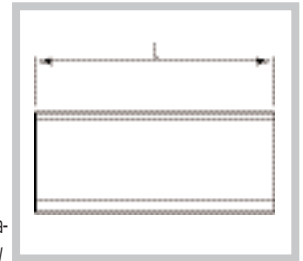

DESCRIPTION

End feed

REFERENCE No.

TR8503

MIN. PACK QTY.

1

DIMENSIONS

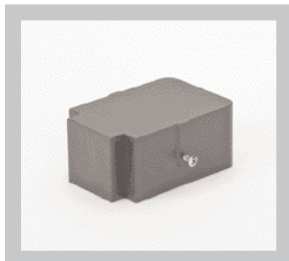
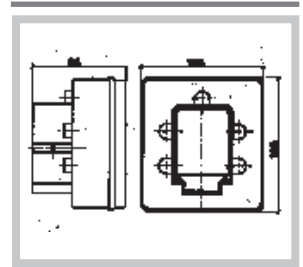

End cap

- To close the ends of the line
- Material: PA 66/FV

TR8506

1

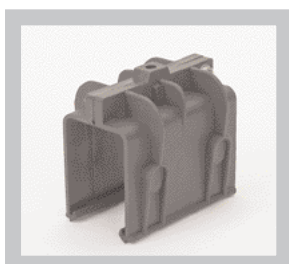
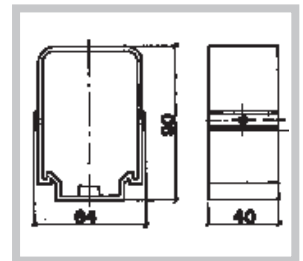

Joint cover

To join the ends of two conductor rails. If fixed to the support arm, it acts as a fixed point to distribute the linear expansion.

- Material: PA 66

TR8501

1

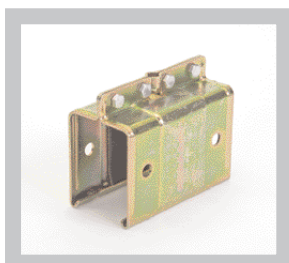
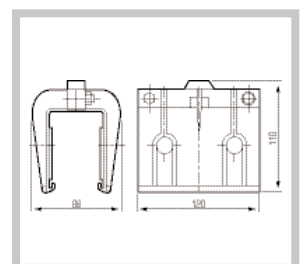

Steel joint cover

To join the ends of two conductor rails.

- Material: Galvanised steel

TR8524

1

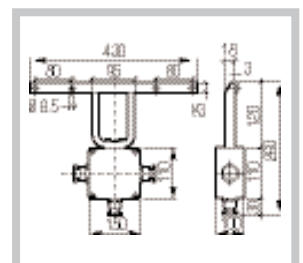

Energy and data transmission

TR85 Series

Conductor rails - Line B "Continuous strip" type

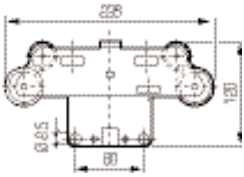
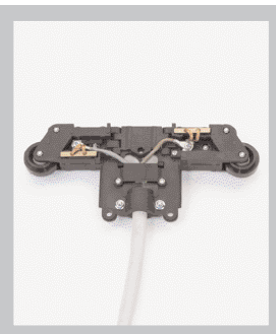
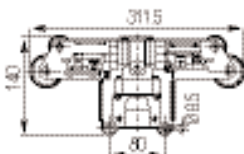
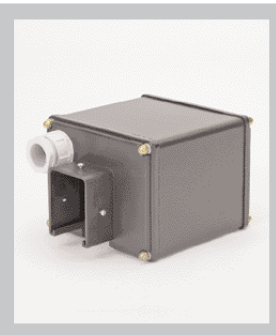
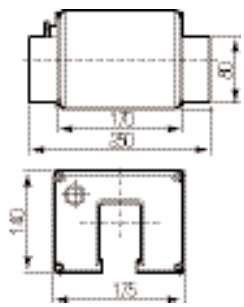
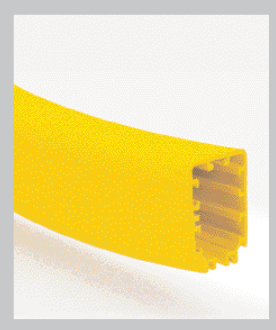
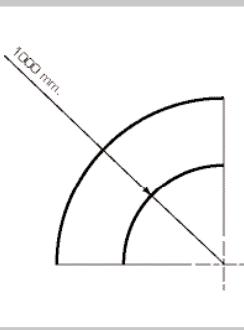
	DESCRIPTION	REFERENCE No.	MIN. PACK QTY.	DIMENSIONS
	<p>35A current collector trolley Fully insulated body with copper graphite collector shoes. Wheels equipped with ball bearings</p> <ul style="list-style-type: none"> ■ 35A 3-pole ■ 35A 4-pole ■ 35A 5-pole 	<p>TR8521</p> <p>TR8511</p> <p>TR8512</p>	<p>1</p> <p>1</p> <p>1</p>	
	<p>70A current collector trolley Fully insulated body with copper graphite collector shoes. Wheels equipped with ball bearings. For current rating over 70A, connect more trolleys in parallel</p> <ul style="list-style-type: none"> ■ 70A 3-pole ■ 70A 4-pole ■ 70A 5-pole 	<p>TR8522</p> <p>TR8518</p> <p>TR8519</p>	<p>1</p> <p>1</p> <p>1</p>	
	<p>In-line feed</p>	<p>TR8526</p>	<p>1</p>	
	<p>Curve</p> <ul style="list-style-type: none"> ■ Curve radius: Special radiuses can be made to order. Minimum Radius: 1 m 	<p>TR8529</p>	<p>1</p>	

Energy and data transmission

TR85 series

Conductor rails – Line A and B



TECHNO-CONTROL EQUIPMENT

ACCESSORIES - SPARE PARTS

SEALING STRIPS

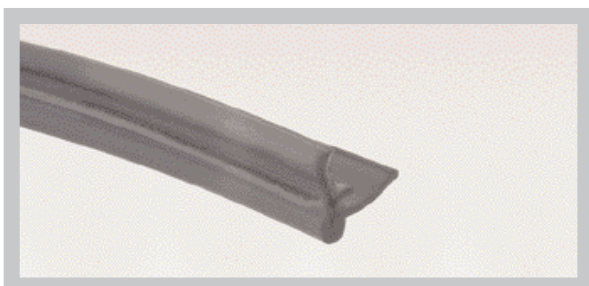

They protect and safeguard the operators.
Please note, order double
the length of the line

TR8505

INSPECTION JOINT

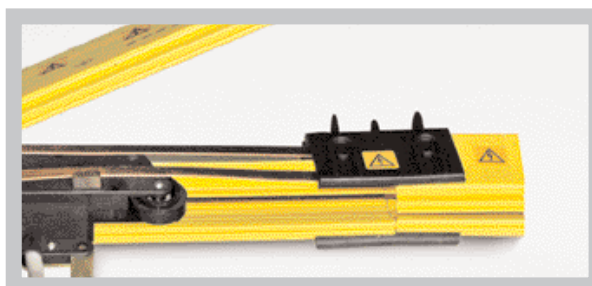

Generally used in long lines, it favours ease
of maintenance and current collector
trolley replacement

TR8528

COLLECTOR SHOES



35A trolley

TR8517

70A trolley

TR8520

FIXED POINT



TR8527

INSTALLATION ACCESSORIES

DE-COIL UNIT



TR8513

STRIP INSERTION TROLLEY

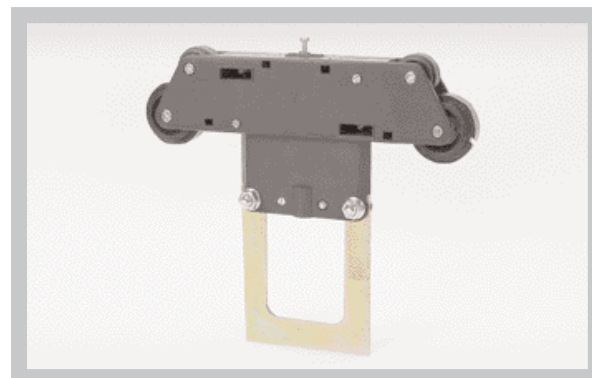

TR8514

Conductors

CP series

Flat cables

FLAT CABLES - IN HO7VVH6-F ANTI-AGING PVC

Particularly suitable for supply and control circuits, lifting and handling equipment.

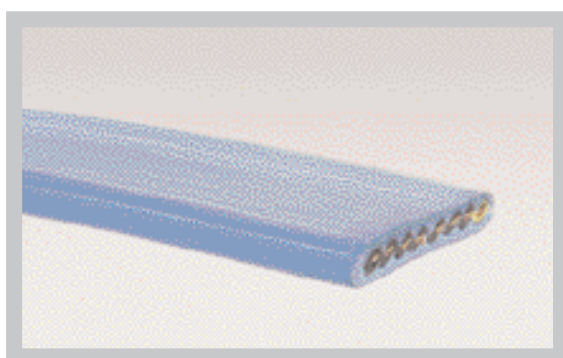

- Comply with CEI 20-22 II (flame resistant)
- Insulation class 2/3
- Operational voltage 450/750V
- Sheathing colour: blue
- Internal flexible conductors with PVC sheathing progressively numbered, plus earth conductor (yellow/green)
- Operating temperature -5 °C +70 °C

REFERENCE No.	CROSS SECTION	APPROXIMATE OUTER DIMENSIONS	STRAND	APPROXIMATE WEIGHT	TOTAL CROSS SECTION	REFERENCE No.	CROSS SECTION	APPROXIMATE OUTER DIMENSIONS	STRAND	APPROXIMATE WEIGHT	TOTAL CROSS SECTION
CP0415AF	4X1,5	15X5,2	30X0,25	150	6	CP2425AF	24X2,5*	54X13	50X0,25	1.100	60
CP0815AF	8X1,5	29X5,5		300	12	CP0404AF	4X4	21X7,5	56X0,30	330	16
CP1215AF	12X1,5	41X5		420	18	CP0804AF	8X4	38X5		550	32
CP1615AF	16X1,5	54X8		510	24	CP0406AF	4X6	24X8	84X0,30	440	24
CP1815AF	18X1,5	43X11		700	27	CP0806AF	8X6	38,5X8		742	48
CP2415AF	24X1,5	51X13		1.000	36	CP0410AF	4X10	35X11	7X12X0,40	800	40
CP0425AF	4X2,5	21X5,7	50X0,25	240	10	CP0416AF	4X16	36,5X12	7X18X0,40	1.200	64
CP0825AF	8X2,5	33X6		420	20	CP04250AF	4X25	43X13	7X28X0,40	1.700	100
CP1225AF	12X2,5	50X7		640	30	CP0435AF	4X35	50X14	7X39X0,40	2.050	140
CP1625AF	16X2,5	41X13		1.000	40						
CP1825AF	18X2,5*	50X13		1.050	45						

Upon request, minimum order 500 m, the same cables can be supplied with:

Heat resistant up to 105° tinned red copper shield.

* 500 m minimum

Conductors

CT series

Round cable with dual strain relief cords



TECHNO-CONTROL EQUIPMENT

ROUND CABLE WITH STRAIN RELIEF STEEL WIRES - S05VVD7-F

Designed for heavy duty applications in particular for pendant push button stations and moving electromechanical parts.

The two built-in steel wires are on the opposite sides of the PVC sheathing.

When correctly dimensioned and secured to the winch, the strain relief cords avoid stresses to the cable.

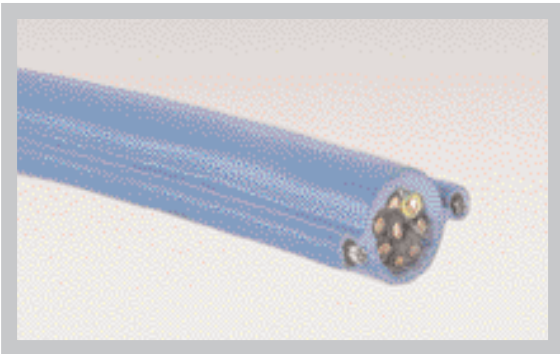

- Comply with CEI 20-22 II (flame resistant)
- Insulation class 2/3
- Operational voltage 300/500V
- Sheathing colour: blue
- Internal flexible conductors with PVC sheathing and progressively numbered, plus earth conductor (yellow/green)
- Operating temperature -5°C +70°C
- 2 Ø mm steel wires
- Breaking point: 60 kg/mm²

REFERENCE No.	CROSS SECTION	APPROXIMATE WEIGHT CABLE Ø		STRAND	APPROXIMATE WEIGHT	TOTAL CROSS SECTION
CT0815AUAF	8X1,5	11,6	23,6	30X0,25	225	12
CT1215AUAF	12X1,5	14,4	26,4		315	18
CT1615AUAF	16X1,5	16	28		415	24
CT1815AUAF	18X1,5	17	29		470	27
CT2015AUAF	20X1,5	18	30		525	30
CT2415AUAF	24X1,5	21	33		620	36

ACCESSORIES - FLAT CABLE GLANDS

PA CABLE GLAND



12903010

PA CABLE GLAND



To be discontinued

REFERENCE No.	THREAD	CABLE ENTRY	CABLE CROSS-SECTION
12903001	1"	19X7	4X1,5
12903002		25X9	4X2,5 - 4X4 - 4X6
12903003	1" 1/4	32X14	4X10
12903004		34X7	8X1,5 - 8X2,5
12903005	1" 1/2	38X8	8X4
12903006		38X12	4X16
12903007	2"	46X16	4X25 - 18/24X1,5 - 16X2,5
12903008		70X8	12X2,5 - 16X1,5 - 4X35
12903009		46X9	12X1,5 - 8X6



General catalogue
2005 edition
Developed and designed by
GasGas sas
Via cortina D'Ampezzo, 12
20139 Milano
Printed by
Mediaprint S.r.l.
Via Mecenate, 76
20138 Milano